

# Canton Edition Observer & Eccentric

Volume 1 Number 47

Monday, April 21, 1975

Canton, Michigan

24 Pages

Fifteen Cents

## For DPW, firemen

# Labor talks pick up

By RICHARD GOLD

CANTON—Money. That is one issue that may hang up contract negotiations between newly unionized firefighters, DPW employees and township officials.

Clerk John Flodin is bargaining from the township's side of the table, replacing Treasurer Carl Parsell when talks bogged down on both fronts.

"I haven't had any problems yet, but if I had to guess what would be a problem area, I would have to guess money," said Flodin.

Talks with the DPW employees began in October 1974 and according to one union member, "it's been a circus." He added, "We've made some progress with Flodin."

DPW representatives have met with Flodin twice after negotiating at various times with members of the old board, Parsell, and Trustee Bob Myers.

"THEY'VE BEEN stalling us. The building department and office workers are going to vote on joining the union (American Federation of State, city and Municipal Employees, a division of the AFL-CIO. I think they're trying to show them it's not the way to go," said one DPW employee.

"We don't even know what the issues will be in this contract. It's a pretty standard agreement we're seeking, but before we started talking with Flodin, we couldn't even work out the language in the contract, much less the substantive issues. Right now, I'd say we are about half way through the language of the contract," he commented.

The seven member bargaining unit has yet to be assigned a local number. That will happen when a contract settlement is reached. DPW employees voted unanimously to join AFSCME in the summer of 1974.

The most recent contract with DPW employees, an 18-month agreement, expired in October 1974. "It was an employe contract, not a union contract," said one DPW worker. According to Flodin, the union contract will be far more specific and detailed.

Unlike the DPW workers, firemen had no formal contract. Much of their bargaining effort has been centered around formalizing current practices and procedures into a written agreement.

Both Flodin and union negotiators expect to see "a lot of carry over into the contract" from current practices.

FLODIN AND MYERS met with state and local representatives of the firefighters union all day April 15. "It was a good meeting, we got a lot accomplished," said union president Art Winkel. "We got a lot of minor points out of the way and we submitted our wage demands."

Flodin commented, "Things went well. I think. This is a first for me. I've never really been involved in contract negotiations before."

He added, "Since this is the first contract ever, it takes a lot of work. We have to work out everything; pay, benefits, working conditions, discipline, promotions, uniform allowances, vacation time—the whole shooting match."

The firemen had been negotiating with Parsell "heavily" since the first of the year. "We were willing to talk to him, but we weren't getting anywhere," said one union member.

However, union officials seem pleased with Flodin. "He's very cooperative and we are making headway," said Winkel.

According to Flodin, the firemen are not seeking significant changes. "There's nothing radical in their demands," he said. "The only area of trouble might be over wages. We will probably continue the benefit arrangements as they are now."

Currently, firemen receive life insurance, medical coverage, two days personal leave, 12 days sick leave and a clothing allowance.

UNION OFFICIALS indicated they were satisfied with current fringe benefits as well as working conditions.

Winkel and union vice president Frank Chakrabarty agreed with Flodin that the tough issue might be money.

Said Chakrabarty, "We are seeking an increase, but I don't think our wage demands are out of line."

Added Winkel, "The only possible problems might be the wages and time and a half for overtime. There's a case in the courts right now about time and a half and we'll know better after that is settled as to what our status is."

He continued, "We don't even know if we will have any problems over money. We gave them our wage presentation Tuesday (April 15) and they said they'd study it."



RELIEF COMES in many ways. For residents of Maben Road relief came in the form of a Wayne County Road Commission grader who smoothed away some of winter's damage.

## At Plymouth Center for Human Development

# Store gives residents choice

By DARLENE STINSON

"You feel as good as you look," the old cliché goes.

Staff members at the Plymouth Center for Human Development have taken the saying to heart.

A new clothing store, offering an entire gamut of men's, women's and children's garments, today opened on the grounds of the state home for the mentally retarded to pump new life into the appearance and outlook of residents.

The store, where supervised residents will select their own articles of clothing, will replace the center's old method of issuing garments, under which huge consignments of pants, dresses and shirts were sent to each ward.

"As a result, the people looked like typical institution residents," said Dr. Elizabeth Ring, Ph.D., a unit director at Plymouth Center. "They had that wrinkled, ill-fitted look.

"THIS STORE will permit individualized attention to the clothing needs of our residents," Dr. Ring explained. "It's our belief that every resident, no matter how retarded, has a right to appear as attractive as he or she can."

Until today, residents had little or no say in the clothing which they put on. Piles of garments, arranged by size and type, were sent to each ward for residents' use. The clothes were laundered after a period of wear and sent indiscriminately to another resident of the same body same.

But all that changed today, as residents scanned the racks of brightly-colored dresses and shirts and checkered pants, suits and ties.

A rack of sandals and shoes sits before chairs and mirrors in the store's new shoe department, while life-size mannequins model jackets and bathing suits. Purses hang on the freshly-painted yellow walls, and jewelry, cosmetics, and sun glasses entice residents from behind a glass showcase.

"EVERYTHING'S like a regular store," said Dr. Ring, pointing out the orange carpet, fitting rooms and soft music, which emanated from a stereo console.

She explained, "The aim was to make this look like a store in the community, so it would serve as a good training setting. This whole thing is based on the principal of normalization—that every resident has a right to be treated in a manner that's as normal as possible. It provides a training setting within the institution that will provide a normal community experience of picking out clothes.

"We have many residents, who will eventually go into the community," Dr. Ring continued. "They'll have to know how to pick out appropriate clothes for the occasion and the season and know how to coordinate colors."

The goal of the clothing store, she explained, is to provide every resident with seven complete outfits for each season plus underclothing and outer garments. Ward supervisors will keep personal clothing records for each resident.

STAFF MEMBERS will alter the state-issued and donated clothing to fit each resident properly and stamp residents' names on the inside of the garment.

The slogan "He'll do better if he looks better," borrowed from John Smith Men's and Boy's Wear in Plymouth, hangs above a full-length mirror and reflects the hopes of staff members.

"We feel it will develop a sense of personal worth in residents," explained Dr. Ring. "Before, clothes were just piled in sizes, and everything looked pretty much the same. Now,

Continued on Page 3A

## Canton cleanup begins in May

CANTON—March winds and April showers are followed by May cleanup—at least that's what Canton Township residents are being encouraged to do as the township board declared May "Canton cleanup month."

Commented Clerk John Flodin, "We are looking for help in cleaning up the township. Right now there is a real need for citizen participation."

As part of the cleanup effort, the township will be offering assistance to organizations interested in cleaning up their neighborhoods.

"The township should be able to supply dump trucks and pickups and possibly men from the Department of Public Works," explained assistant ordinance officer Bruce Phillips.

At least one civic association has scheduled a neighborhood and road-side cleanup campaign and township officials are hopeful more are on the way.

The Northwest Canton Homeowners Association will hold its neighborhood cleanup May 10.

Flodin said, "Right now, a lot of people don't realize that lots of their large items can be handled in normal rubbish pickup. Our trucks are capable of handling large household items such as refrigerators or stoves. If not, special runs can be arranged."

Those interested in using township trucks for cleanup drives are encouraged to contact the township offices as early as possible.

## Detroit water rates get suburban studies

Two meetings will be held next week on consecutive days to investigate the Detroit Water Department rate structure and suburban representation on the water board of commissioners.

The first will be a state House of Representatives special committee hearing set for 10 a.m. next Monday, April 28, in the Livonia Senior Citizens' Activities Center, 15218 Farmington Road, south of Five Mile.

State Rep. John Bennett, committee chairman, invited public officials whose communities are customers of the Detroit water department to voice their views.

BENNETT SAID the committee has scheduled four public hearings to look into the water department's operation with the possibility of a fifth hearing at Flint.

"I hope this investigation will shed some light on apparent problems which seem to exist in the Detroit water system operation and its rate structure," Bennett said.

The other meeting was called by Mayor Edward McNamara of Livonia for a committee of 16 cities. That meeting will be at 7:30 p.m. Tuesday, April 29, in McNamara's office in City Hall, 33001 Five Mile.

That committee will discuss ways to guarantee suburban representation on the water board.

The board has seven members with four from Detroit and the suburbs. McNamara serves on the board to represent Wayne County.

The board's membership could be changed in the future since the new Detroit city charter, which creates the water board, requires that at least four members be from Detroit.

BOTH COMMITTEES were created last month after McNamara, as board member, opposed a proposed 35 per cent water rate hike, recommended by Water Department Director Ernest Cedroni.

McNamara's opposition was based on numerous budget increases which he felt were unjustified or not fully explained.

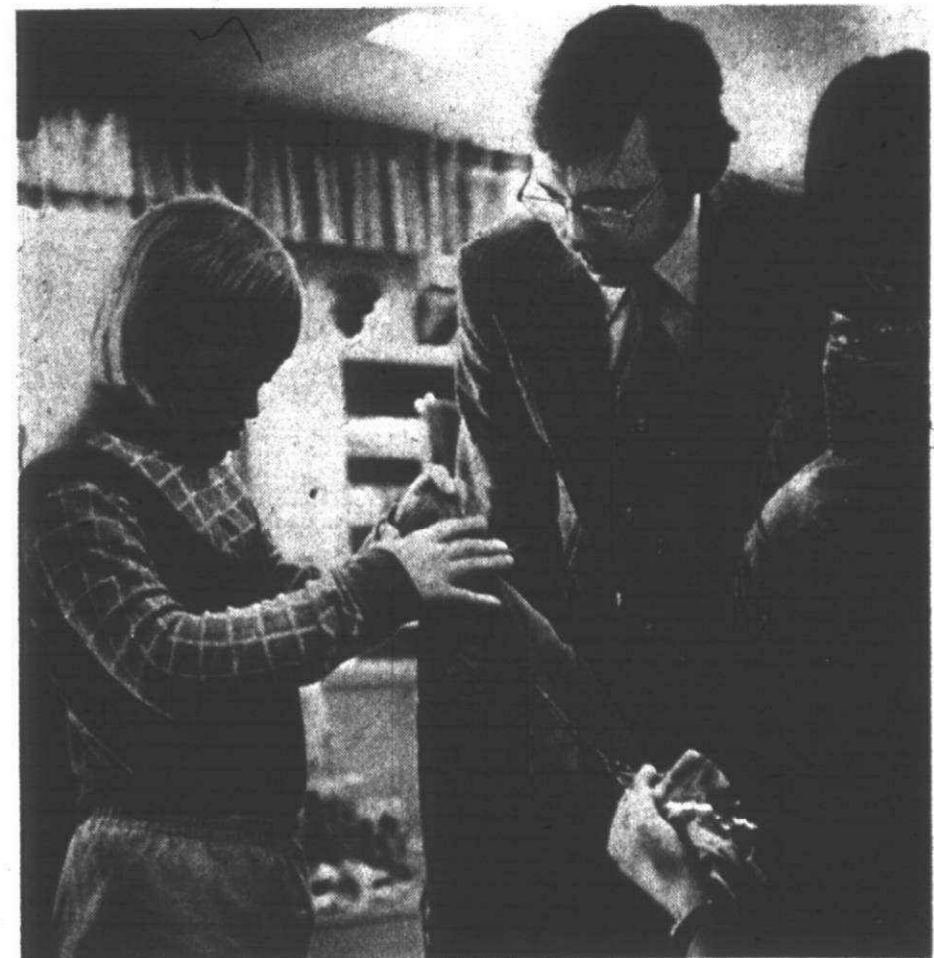

SELECTING YOUR OWN clothes is fun, especially when its opening day at a new store for residents of the Plymouth Center for Human Development. Fred Hill (center), owner of John Smith Men's and Boy's Wear in Plymouth and a member of Plymouth Center's clothin store advisory committee, helps Plymouth Cen-



VOTER REGISTRATION by the League of Women Voters began last Friday for high school students. Students at Plymouth Canton High School were the first to add their names to the voting rolls. The procedure will be re-

peated April 26 in Plymouth Salem High between 8:40 a.m. and 11 a.m. Filling out his forms is Canton senior Robert deBear, aided by league member Janet Stacy. (Staff photo by Bob Woodring)

## inside

Brevities	6A
Classified Want Ads	Section B
Crackerbarrel Debate	10A
Deaths	5A
Editorial Opinion	10A
Good Life	8A
Sports	12-13A
Suburban Life	11A
Stroller	10A

SENIOR CITIZEN needs will be discussed in six public hearings around the Detroit metropolitan area. Page 2A

HUNDREDS OF ice skaters will gather on May 2-3 for a "Change of Pace." Page 3A

**Starting business is workshop topic**

A workshop entitled "So You Want to Start a Business" will meet Tuesday evenings, starting April 22, for six weeks at the Lawrence Institute of Technology.

Tuition is \$60 per person. Study materials and parking are provided. The workshop will be in a conference room off the lobby of the Science Building on the campus, Northwestern at 10 Mile, Southfield.

Any interested adult may enroll, including those who are already in business. There are no formal education requirements for admission. The workshop is co-sponsored by LIT and the Small Business Administration.



LOCAL 42 STRIKERS march across the driveway leading to the UAW-run Metro-West Hospital in Westland.

# Metro-West Hospital employes go on strike

By DENNY COFFMAN

WESTLAND—Members of Local 42 of the Office and Professional Employees International Union (OPEI) were striking UAW-administered Metropolitan Hospital-West in Westland and Metropolitan Hospital in Detroit following a strike vote Thursday night.

The two hospitals are run by a board of directors including Ken Bannon, UAW vice president; Emil Mazey, UAW treasure and John Bate-man, UAW auditor.

Local 42 has about 450 members, 80 of whom are employed at Metro-West. Its membership includes office, accounting, dietary, housekeeping, medical records and medical attendant personnel.

UNION and management had met with the Federal Mediation and Conciliation Service late Monday night and early Tuesday in a last-minute attempt to resolve differences.

The hospital made several new proposals Tuesday, and union officials called for a membership vote Thursday night.

The vote against the contract proposals was 284-84, and the strike began at 6 a.m. Friday.

Strike committee member Carol Hollman Friday claimed Mazey had attempted to persuade OPEI president Howard Coughlin to rescind his authorization of Local 42's strike.

A telegram the local received from Coughlin indicated he would not authorize the strike, but neither would he take any legal action to prevent it,

according to Mrs. Hollman and Geri Maciniak, another committee member.

WHILE about 35 strikers formed a picket line in front of Metro-West by noon Friday, executive hospital administrator William Rothman said hospital business was "normal."

"We have had 100 per cent of our people come to work today," he said. "Everything is running very well. Only a very few have not shown up for work."

Doctors, nurses and technicians crossed the picket line, as did most of the patients, Rothman added.

SEVERAL picketers claimed "police harassment."

"The Westland Police have prevented us from handing out literature" to patients and other employes entering the hospital, Mrs. Maciniak asserted.

One of the officers stationed at the hospital, Ptl. Dan Harvey, claimed the city has a handbill ordinance requiring a permit to distribute literature.

However, an employe in the Westland city clerk's office Friday said no permit is required other than for house-to-house handbill distribution.

"WHAT WE object to," Harvey

said, "is their knocking on car windows. If someone asks for the literature, it's OK."

Harvey said a group of strikers blocked the driveway to the hospital's emergency entrance, and when a driver refused to stop, the strikers pounded on the car.

By late Friday morning, strikers were orderly, permitting patients to enter, though greeting some with shouts of "Let the hypochondriacs through."

LOCAL 42 has been working without a contract since Feb. 1 this year. Union officials say the membership is seeking the same benefits it claims the UAW has sought for its own members in auto talks.

Objections to the hospital's proposed contract centers around four issues: cost-of-living allowance; sickness and accident benefits; an extension of the current contract term of two years to three; and a speedup caused by doubling the workload while increasing the number of employes only slightly.

The union also charges the hospital with preventing union activities on the premises.

Local 42 has a strike fund paying strikers \$20 per day, but the fund is expected to run dry in about two weeks.

## Agency to hold hearings

Six public hearings in Detroit and three suburbs, including Livonia, have been scheduled by the Detroit-Wayne County Area Agency on Aging to hear residents' views on the needs of senior citizens.

At 10 a.m. Thursday, April 24, a hearing will be held in the Livonia Senior Citizens Center, 15218 Farmington Road. Another hearing will be held at 10 a.m. Friday, April 25, in the Romulus City Hall, 11111 Wayne Road.

The agency wants to hear public reaction as it is finalizing its funding goals for the fiscal year beginning July 1.

The resulting area plan will be submitted to the Michigan Office on Aging to qualify Detroit and Wayne County programs for the aged for \$791,730 under the U.S. Older Americans Act.

Major objectives of the plan are development of health preventive and counseling services, programs to allow the elderly to live in their own homes, and information and referral services for seniors.

The proposed area plan is available for review at the agency's offices, 2516 David Stott Building, 1150 Griswold, Detroit, Monday-Friday from 8:30 a.m. to 4:30 p.m.

**ADLER TYPEWRITERS**  
 Portable \$79.00  
 Office Electric \$120.00  
**MARAGON BUSINESS MACHINES**  
 26541 Plymouth  
 937-8811  
 Sales-Service-Parts

**SPRING CREST**  
 IS COMING!

**BOTSFORD INN DINNER THEATRE**  
*Larry Lawrence*  
 MASQUERADE IN MUSIC  
**FACADES**  
 May Dates:  
 May 1, 8, 14, 21, 22, 28, 29  
 For Reservations, Call  
**Botsford Inn**  
 "SINCE 1836"  
 28000 Grand River • 474-4800

**HAPPY BARGAIN DAYS**  
**ARE HERE AGAIN**

**TOPS** \$5.50  
 Blues, pinks, beiges. Sizes Small, Medium & Large

**SHIRTS** \$7  
 Polyester prints. Sizes 8-16. Regularly \$14

**2 Pc. PANTSUITS** \$26.90  
 Polyesters & cottons. Sizes 6-16

**HALTERS** \$2.50  
 Solids & patterns. Sizes small, medium, large. Regularly \$5

**SWEATER VESTS** \$6  
 Pull-overs. Sizes small, medium, large. Regularly \$12

**SLACKS** \$13  
 Polyesters. Sizes 6-16. Regularly to \$20

**HARVI'S of northville**  
 Northville Square Store Only

**DETROIT COUNTRY DAY SCHOOL**  
 Est. 1914  
 COEDUCATIONAL UNIVERSITY PREPARATORY CURRICULUM

**Announces its next admission testing date: Saturday, April 26, 1975—8:45 a.m.**

Admission Testing and Interview Arranged by Appointment  
 13-Mile and Lahser, Birmingham, Michigan  
 Phone: 646-7717 Ext. 231

- DISCRIMINATION by ability, ambition, achievement, character, and motivation, NOT RACE, CREED OR COLOR
- Coeducational Programs Lower — K-4 Middle — 5-8 Upper — 9-12
- EMPHASIS: ACADEMIC EXCELLENCE CHARACTER DISCIPLINE SELECT FACULTY PUPIL-TEACHER RATIO: 12 to 1 ACADEMIC ACCOUNTABILITY INDIVIDUAL COUNSELING
- GRADUATES: 100% attend universities approximately 50% attend graduate school
- EXTENSIVE ATHLETIC PROGRAM: At All levels
- EXTENSIVE ACTIVITY PROGRAMS: including band, orchestra and chorus
- EXTENSIVE FINE ARTS PROGRAM
- TRANSPORTATION: available on school buses

A quality education for those who care enough

**WINDOW GUARD PROTECTION**

- RESIDENTIAL
- COMMERCIAL
- FREE EST.

✓ Hundreds of Styles  
 ✓ Mesh Type  
 ✓ Bar Type

**532-2282** **HOUSE OF IRON**  
 15721 Dale, Redford

**TILE & CARPET SPECIALS**

<b>NYLON SHAG CARPETING</b> Compare at 6.99 <b>4.99</b> sq. yd.	<b>KITCHEN CARPETING</b> With Rubber Backing <b>3.99</b> sq. yd.	<b>Famous Maker Self-Stick Vinyl Asbestos FLOOR TILE</b> 45 sq. ft. per box <b>10.99</b>
<b>ARMSTRONG SOLARIAN®</b> \$7.95 sq. yd.		<b>Ceramic WALL TILE</b> 4 1/4 x 4 1/4 <b>59¢</b> sq. ft.
<b>Vinyl Asbestos FLOOR TILE</b> 12 x 12 45 sq. ft. <b>5.99</b> per box	<b>LINOLEUM RUG</b> 9 x 12 <b>6.99</b>	<b>Armstrong CARPET TILE</b> 12 x 12 Self Stick Back <b>33¢</b> ea.
<b>AJAX FLOOR COVERING</b>		<b>Ceramic FLOOR TILE</b> Now Only <b>69¢</b> sq. ft.

FREE ESTIMATES EXPERT INSTALLATIONS 427-6620  
 32639 FORD RD. (S. of E. of VENOY)

**SPRING IS THE TIME TO CALL THE GREEN MACHINE**

The Green Machine people are the "professionals" you can depend on to weed and feed your lawn.

All Green Machine products are specially formulated, and used exclusively by Kaltz. It's called the Slurry Process which contains VERMICULITE, the ingredient that gives your lawn longer lasting nutrient value.

The Green Machine specialists will inspect your lawn and outline a lawn care program absolutely FREE. You will know what is to be done and what it will cost to keep your lawn healthy and green.

Call now—541-0540 or 564-6408 . . . FOR A FREE LAWN SURVEY

Let the Green Machine weed and feed your lawn with . . . special products . . . special equipment . . . professionally applied . . . at about the same cost as do-it-yourself.

**KALTZ**  
 Call now . . . 541-0540 or 564-6408 . . . and let the "Professionals" and the Green Machine make your lawn healthy and green. Serving South Oakland County since 1919.

**Let Playgirl put you back into things...**  
 (like last season's dresses, jeans, pantsuits and bikini.)

More of you in the mirror these days? Now is the time to do something positive for your image. At Playgirl we offer figure control programs of 4, 6 and 12 months designed to fit your individual needs. Playgirl can help you get into the latest fashions at the slimmest of prices.

**Now Available! 30 DAY PROGRAM Limited Time**

**Call Now For SPECIAL PROGRAM Offer Of The Week**

**Playgirl FIGURE SALONS**

Call for free visit and figure analysis

Ann Arbor (East) 973-2180	Pontiac 661-3333
Ann Arbor (West) 994-4777	Southgate 283-5500
Centerline 755-7100	Troy 524-8410
Dearborn Heights 565-2077	Ypsilanti 487-5300
East Detroit 772-6200	
Farmington 477-2211	
Livonia 421-5500	
Madison Heights 545-8600	
Oak Park 545-5222	

Open Monday thru Friday 9 to 9, Saturday 9 to 5, Sunday 12 to 5

# City police vote teamsters in

By RICHARD GOLD

PLYMOUTH—City officials, sitting down at the bargaining table with police this summer, will be facing a new bargaining agent.

On Thursday, April 17, members of the Plymouth Police Officer's Association (PPOA) voted 10-1 to join the International Brotherhood of Teamsters. "Basically we joined because we are police officers first and shouldn't have to worry about the day to day responsibilities of union work or contract negotiations. By joining the Teamsters we are putting these responsibilities in the hands of a professional," said PPOA president Michael Gardner.

He added, "We are not dissatisfied with anything in particular, we just thought this would aid us in our professional duties."

**THE CURRENT** two year agreement expires June 30. It had been negotiated by officers of the PPOA.

Police Chief Tim Ford had no comment.

Ray Quada, administrative assistant to the city manager indicated the change was not significant.

He said "They have a perfect right to representation, whomever they choose. It just means we'll be dealing with Teamster representatives rather than PPOA representatives."

The bargaining unit is composed of 12 patrolmen and sergeants. The police chief, assistant chief, lieutenants,

community service officer and ordinance officer are not eligible to join the union.

Explained Gardner, "All non-supervisory sworn police officers are eligible to join."

Gardner said the move to join the teamsters would not mean the end of the PPOA. "That will continue to exist," he said, "but the teamsters will be handling our contract talks."

Thursday's vote was held before officials from the Michigan Employment Relations Commission who certified

the change in bargaining units. According to Gardner, state law dictates any change in bargaining agents must be recognized by the state commission.

**DESPITE** the increased dues and initiation cost, Gardner said the PPOA approached the Teamsters. "We started thinking about this about two months ago," said the patrolman, "and we were nearly unanimous in our decision to join."

Gardner, PPOA secretary patrolman Roger Roy and treasure, patrol-

man Larry Ray will assume the local Teamster positions of chief steward, bargaining officer, and steward.

Police officers will meet with Teamsters officials on May 5 to formulate a bargaining schedule for this summer. "We'll set up a program and present it to the city right away," said Gardner. "If they agree, then we can begin negotiations soon thereafter."

The current police contract became effective July 1, 1973 after it was approved by the city commission.

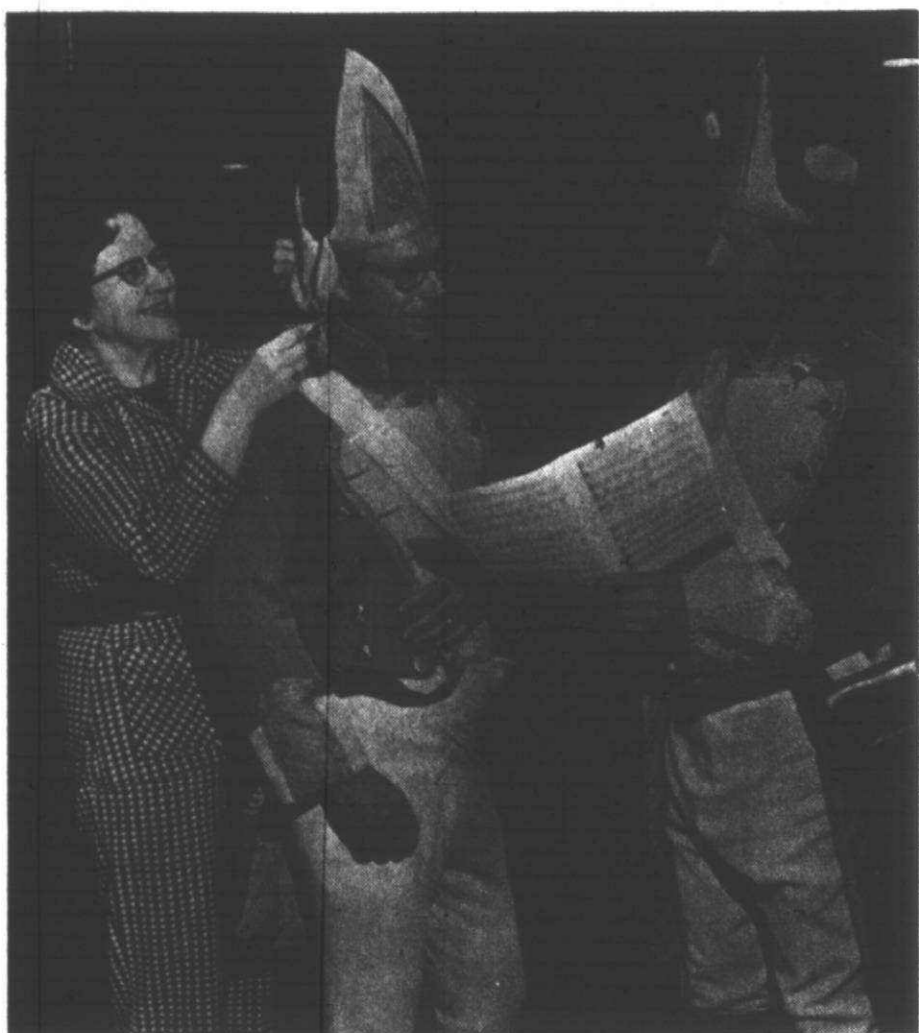

EDITH DURANCEAU makes some costume adjustments as Bob Cooper (center) and Chuck Heidt go over the score for "The Barber of Seville." Chuck and Bob will be joined by 14 other voices of the Plymouth Men's Chorus, plus the Plymouth Symphony Orchestra, and the Michigan Opera Theatre for the 8 p.m. April 26 production in Plymouth Salem auditorium. Tickets are priced at \$5.50 and cover the cost of the MOT's visits in Plymouth schools throughout the week. For tickets, drop by the Plymouth Community Arts Council box office in the Detroit Edison office, Ann Arbor Trail and Main. (Staff photo by Art Emanuel)

## School bridges to lessen safety hazards of roads

PLYMOUTH TOWNSHIP—Students attending Bird Elementary and West Middle schools will not have to cross through Ann Arbor Trail and Sheldon Road traffic, when autumn winds blow next fall.

The Plymouth Community School Board Tuesday voted 4-1 in favor of constructing pedestrian overpasses over Ann Arbor Trail and Sheldon and awarded the contract to the low bidder, Spartan Sign Co., for \$80,384.

Trustee Gary Mirto cast the lone dissenting vote, while trustees George Lawton and Carl Berry were absent from the voting procedure.

The contractor will construct the

overpasses so they can be dismantled and moved to another site, according to Secretary Marcia Borowski's motion.

That motion directed school board members to study boundary attendance areas and eliminate major street crossings by 1976.

The district's safety committee and attendance boundary committee recently met to discuss the proposed overpasses, according to Mrs. Borowski. Some persons objected to the busy roads which students must currently cross, she said.

Construction of the overpasses should begin almost immediately, said board President E.J. McClendon,

and the bridges should be ready when school starts next fall.

A 0.4 mill safety levy, which voters approved last year, will fund the overpass project, McClendon said.

Mirto voted against the overpass, because he believes Plymouth Township should share the costs. The school district and Plymouth and Canton townships shared the costs of a similar overpass at Fiegel School, he said.

"This overpass is needed," Mirto said, "but we haven't been able to effect the same kind of cost-saving program as at Fiegel. Our resources should be used for educational purposes."



SUSPENSE AND INTRIGUE await elementary students throughout the Plymouth Community Schools through the end of next month as Anne Ardanowski (left) and Chris Gural are joined by other Central Middle School students in their production of "Shirley Holmes

and the FBI." The traveling company will take its production out each Monday morning as the "super sleuth" (a liberated detective), tries to crack the secret code. (Staff photo by Art Emanuel)

## 300 Plymouth-area skaters present 'A Change of Pace'

PLYMOUTH—A billowy circus tent and a dark, Roaring Twenties nightclub will take over the Plymouth Cultural Center's ice arena May 24 when 300 skaters, enrolled in classes sponsored by the Department of Parks and Recreation, present "A Change of Pace."

Skaters will present the ice show at 7:30 p.m. Friday, May 2, and Saturday, May 3, and at 3 p.m. Sunday, May 4.

Advance tickets, priced at \$2 for adults and \$1 for children, must be purchased in the Cultural Center by 5 p.m. May 3. Tickets at the door are \$2.50 for adults and \$1.50 for children.

Barbara Thacker, head instructor of ice classes in the Cultural Center and ice show director, expects more than 5,000 persons will view the three performances.

**THE FIRST HALF** of the show, which centers on a circus theme, begins with a precision group of skaters who glide over the ice in routine formation, throw popcorn to the audience and set the circus mood.

A little girl and her parents glide out to view the performance, while a ringmaster, clowns and unicyclists follow close behind. Skaters dressed as

lions, tigers and bears further the circus mood and perform their antics to music taped beforehand.

The second half of the show is dedicated to a Roaring Twenties nightclub, and tables, chandeliers, waitresses and dancers set the night-spot mood. Song hits from the '20s are featured.

"It's not a recital, but a real show," said Mrs. Thacker. "It's really a fantastic experience for skaters. It's kind of a reward for all their work."

**ABOUT 300** of the 900 persons enrolled in the Recreation Department's skating classes have volunteered to participate in the program, Mrs. Thacker said. Performers range in age from three-year-olds to grandparents. All are amateur skaters.

Instructors began gathering ideas for the show last year, not long after skaters presented Plymouth's first ice show, Mrs. Thacker said. Skaters began practicing their whirls and glides last month.

About 20 skaters who are participating in the program sewed brightly-colored costumes for the whole group, she said.

Skating instructors directing the program include Mrs. Thacker, Doris Bal-

sley, Carol Holcomb, Carol Scruggs, Madeleine Snyder, Tom Carlearde, Jeanne Young and Marjorie Marque.

## Clothing store gives choice

Continued from Page 1A

people will have individualized clothing that they can call their own."

Celesta Taylor, head of domestic services, added, "We're moving residents from the institutional look into bold colors. We find if our residents are dressed up and we tell them they look pretty, they do better."

Elizabeth Ring came to Plymouth Center in 1972 from a state institution for the mentally retarded in Connecticut, where the clothing store concept had proved successful. A group of Plymouth Center staff members visited the Connecticut institution and liked what they saw.

A CLOTHING store planning committee, composed of staff members, was formed this fall, Dr. Ring said, to implement the clothing store concept. A \$1,000 federal grant was obtained to outfit the new store. Mirrors, furniture and mannequins were donated by organizations and other state agencies.

Now that the store has opened, the planning committee has evolved into an advisory committee, composed of staff members, a parent, a resident of Plymouth Center, Fred Hill, owner of John Smith Men's and Boy's Wear, and Julie Thoman, owner of Wayside Gift Shop, to deal with problems that may arise.

Ms. Taylor said, "We're hoping the store will cost the center less money in the future than our old method of issuing clothing and keep the students better dressed."

Dr. Ring added, "This kind of thing is going to become more and more prevalent, as we get away from the institutional concept of pushing retarded people away from society."



PLYMOUTH CENTENNIAL EDUCATIONAL PARK seniors Linda Dwyer and Charles Burr are recipients of four-year dramatic scholarships at Eastern Michigan University. The two are among five dramatic scholarship winners, chosen from 1,000 applicants on the basis of faculty recommendations and auditions. Both plan to major in drama and make it their career. (Staff photo).

Center for Creative Studies  
College of Art and Design

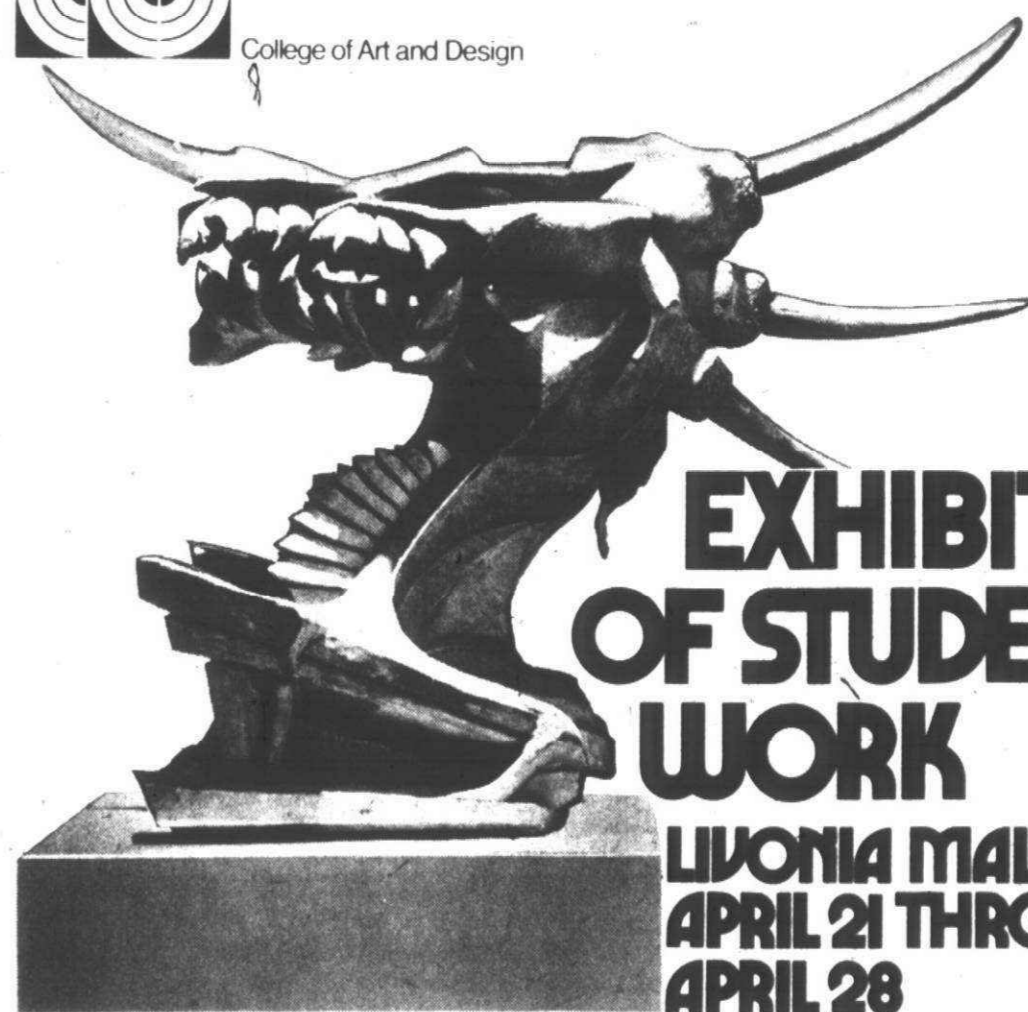

**EXHIBIT OF STUDENT WORK**  
**LIVONIA MALL**  
**APRIL 21 THROUGH**  
**APRIL 28**

This exhibit of student work includes samples from all courses available at the Center for Creative Studies: the Fine Arts—painting, sculpture, graphics; Advertising Design; Photography; the Crafts—ceramics, glass, metalcraft and jewelry, fabric design; and Industrial Design. Degree and Certificate programs are offered.

The Center for Creative Studies, formerly the Art School of the Society of Arts and Crafts, was founded in 1926 as a private, undergraduate art school to "provide students with the facilities, training and experience necessary to the development of a high level of competence in one or more areas of studio art."



**Livonia Mall**

7 Mile Road at Middlebelt  
Open Daily til 9 p.m. Sunday Noon til 5 p.m.

**Canton Observer & Eccentric**  
Co-Publishers  
Henry M. Hogan, Jr. Philip H. Power  
HOME DELIVERY SERVICE  
Newstand..... per copy, 15c  
Carrier..... monthly, 90c



ON TOUR with the Detroit Youtheatre, Lorice Stevens, George Tipton (center) and Ben Carter will present a musical review "From Adam and Eve to Porgy and Bess" today and tomorrow to middle school students in Plymouth. The program is sponsored by the Detroit Institute of Arts and comes to Plymouth through the Plymouth Community Arts Council.

## Musical review comes to Plymouth

PLYMOUTH—The Plymouth Community Arts Council is presenting a musical show entitled "From Adam and Eve to Porgy and Bess," in several area schools on April 21 and 22. Shows will be on the April 21 in Pioneer at 9:30 a.m. and at 1:15 p.m. at Our Lady of Good Counsel. On the April 22 the musical entourage will appear at East Middle School at 9:30 a.m. and at Central Middle School at 1:15 p.m.

The show will star George Tipton and Lorice Stevens, veteran performers of Detroit Youtheatre productions.

Ms. Stevens has performed with touring shows such as "Best of Broadway" in the United States and Canada. A graduate of Howard University, this performance will mark her fourth appearance in the Detroit area. Tipton is a dancer and appeared in the Broadway production of "Hair." A member of the American Society of Composers, Authors and Publishers, he has written songs recorded by Harry Belafonte and Odetta. Their performance will be accompanied by Ben Carter, a veteran composer and arranger.

## Fund raiser set for Special Olympics

LIVONIA—The Civitan Clubs of Livonia, Plymouth and Wayne, co-sponsors of the western Wayne County Special Olympics for retarded and handicapped children, will hold a fund-raising project at 7 p.m. tomorrow (Tuesday).

The clubs, co-sponsoring the April 26 and May 2 Olympics along with The Observer & Eccentric, will show a film and talk about the Olympics in the Roman Chariot restaurant, 32826 Five Mile east of Farmington Road.

The program, which includes dinner, is open to the public and reservations for \$5 may be made by contacting the restaurant by noon, Tuesday.

The Olympics will have children compete in bowling, swimming, and track and field events.

The bowling events will be at Westland Bowl in Westland on Saturday, April 26, with the gymnastics program in Garden City West High the same day.

The swimming, track and field events will be in Wayne Memorial High Friday, May 2.

The Civitans are still appealing for volunteers to work as timers, starters, runners, recorders and "huggers," a special activity which has persons embrace the youngsters at the end of each event to give them a sense of accomplishment.

Interested persons may contact western Wayne County chairman Eric Pfeifer at Troy High School or at his home at 8225 Brooke Park, Plymouth.

## MSU awards degrees to 3 from Plymouth

PLYMOUTH—Three Michigan State students from Plymouth received bachelor degrees at winter term commencement ceremonies.

Bachelor of science degrees were awarded to Caryl A. Davis, 11696 Russell, in criminal justice; and Richard M. Goepf, 9475 Canton Center, in animal husbandry.

Vicky J. Stoyanoff, 11300 Aspen, received a bachelor of arts degree in communications.

## Western hails 8 in Plymouth

PLYMOUTH—Eight Western Michigan University students from Plymouth were named to the dean's list for achieving high marks during the fall semester.

On the list are Eileen K. Evans, 6975 Fosdick; Elizabeth A. Birge, 1294 Maple; David J. Prueter, 15562 Ladeside; Paul G. Szilagyi, (all As) 1482 Sheridan, Cheryl A. Godra, 40338 Ivywood; Mary J. Rogers, (all As) 1627 Gloucester; Martha J. Spear, (all As) 1614 Lexington; and Bradley D. Weage, 750 Sunset.

## Class honors for Bolton

PLYMOUTH—University of Michigan-Dearborn student Samuel Bolton Jr. has received class honors which are conferred on students with a minimum grade of 3.5 for at least 28 credit hours taken during the last calendar year.

Bolton lives at 40345 Plymouth Road.

**PRESCRIPTION COUPON**

COUPON GOOD APRIL 21 thru APRIL 26

WORTH TO

**\$5**

MAXIMUM

LIMIT ONE PRESCRIPTION PER COUPON

**K mart COUPON**

GOOD ONLY AT THESE 2 LOCATIONS

FORD RD. AT SHELDON  
ANN ARBOR AT HAGGERTY

**Sandbox SAND**



For the Plymouth Community  
**PLYMOUTH JAYCEES** \$1.00  
will deliver for -----

A WHEELBARROW LOAD OF SAND  
TO YOUR HOME!

ALL DAY: SATURDAY, APRIL 26th

**CALL 455-3171 or 427-4137**  
BETWEEN APRIL 21-25th  
12 NOON to 8:00 P.M.

**NEW FROM FORD:**

**ROTARY TILLERS!**



Here are three new worksavers from Ford Tractor! Excellent tools for gardening and landscaping.

- Take your choice, a 5-hp chain-driven model, or 5 and 8-hp gear-driven models.
- Each of these new self-propelled Fords is designed for ease of operation and work efficiency.
- Throttle and clutch controls conveniently located
- Tillage depth easily adjusted
- Maximum weight distribution for good penetration
- Easy-spin starter standard
- Make your pick today; start gardening the modern rotary-tiller way tomorrow!

**WALK-BEHIND ROTARY TILLERS. BETTER IDEAS BY THE YARD.**

**CANTON TRACTOR SALES, INC.**  
42045 MICHIGAN AVE.  
WAYNE  
422-1151



JOHN RIBAR

## Ribar named outstanding educator

PLYMOUTH—Dr. John W. Ribar, associate professor of Hebrew at Concordia Senior College, Fort Wayne, Indiana has been selected as an "Outstanding Educator" of 1975. Dr. Ribar will be featured in "Outstanding Educators of America," a national awards publication.

Nominations for the award are based on an educator's talents in the classroom, contributions to research, administrative abilities, civic service, and professional recognition.

Ribar is a native of Plymouth, the son of Mr. and Mrs. Louis J. Ribar of 398 Pacific. He holds a masters of divinity degree from Concordia Seminary in Springfield, Ill. and a PhD from the University of Michigan.

This is the second time he has been selected as an "Outstanding Educator."

**We're working harder than ever to save you money!**

## GOURMET BUDGET DINNER!

Rock Cornish Hens are the smallest members of the chicken family. They weigh almost one pound and generally it's best to allow one bird per person for the average meal. Cornish Hens may be split and broiled but are particularly delicious when stuffed and roasted like chicken or turkey. They are also delicious as left overs when cold. This week beat down your budget with a meal built around Rock Cornish Game Hens. On Special Now!

GOVERNMENT INSPECTED FRESH FROZEN

## Cornish Game Hens

BIG VALUE BRAND. WEIGH APPROXIMATELY ONE POUND EACH. A REAL GOURMET MEAL AT REAL SAVINGS.

**58¢**

SAVE 20¢ lb.

Try a delicious dinner of Game Hens and a Baked Potato

### BUDGET PRICES!!

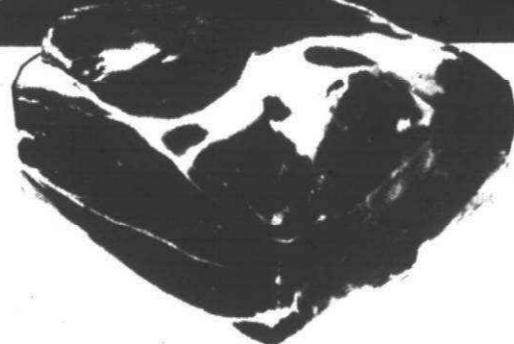

HICKORY SMOKED SMALL LEAN

### Smoked Picnics

WATER ADDED FOR CURING PURPOSES

**58¢** lb. SAVE 17¢ lb.

HERRUD "NEW" ALL BEEF SKINLESS

**Beefeater Franks** FULL 1-LB. PKG. **98¢**

BUTCHER BLOCK QUALITY PORK

**Shoulder Blade Pork Steak** **98¢** lb.

FRESH HAMBURGER MADE FROM

**Ground Chuck** ANY SIZE PKG. **98¢** lb.

TASTY SAVE 3¢

**Silver Floss Sauerkraut** 27-OZ. CAN **35¢**

MEADOWDALE FROZEN SAVE 35¢ ON 3

**Hash Brown Potatoes** 2-LB. PKGS. **3 \$1**



**MONDAY & TUESDAY SPECIALS**

#### Cornish Hens Supreme

- 4 1/2 to 1 1/2 pound ready-to-cook Cornish game hens
  - 1/4 cup butter or margarine
  - 1/3 cup sugar
  - 1 1/2 pound 1 ounce fruit cocktail, drained (reserve syrup)
  - 1/2 cup sauterne
  - 2 tablespoons cornstarch
  - 1/2 teaspoon salt
  - 1/2 teaspoon grated orange peel
  - 1/2 teaspoon grated lemon peel
  - 1/4 cup lemon juice
- Salt inside of birds and truss. Roast hens as you would turkey or chicken. Uncover and baste with melted butter the last hour of roasting. Serve with hot Wine Fruit Sauce. Makes 4 servings.
- Wine Fruit Sauce: Caramelize sugar over low heat in heavy saucepan. Heat fruit cocktail syrup to boiling, slowly add to starch, salt and grated peels. Stir into hot syrup mixture and cook, stirring constantly, until mixture thickens and bubbles. Add lemon juice and drained fruit cocktail. Heat just to boiling. Makes 2 cups.



GENUINE "BAKER SIZE"

**Idaho Baking Potatoes**

**17¢** lb.

BREAST OF CHICKEN, IN OIL OR WATER

### Chunk Tuna

6.5-OZ. CAN **43¢** SAVE 12¢

MEADOWDALE FRESH

### Low Fat Milk

SAVE 12¢

**97¢** PLASTIC GALLON JUG

CAMELOT FRESH

### Giant Bread

SAVE 18¢ ON 2

**2 88¢** 24-OZ. LOAVES

NATIONALLY FAMOUS REGULAR OR ELECTRIC PERK COFFEE

### Chase & Sanborn Coffee

1-LB. BAG **59¢** SAVE 16¢ WITH COUPON AND \$10.00 PURCHASE

VALUABLE COUPON

REGULAR OR ELECTRIC  
**Chase & Sanborn Coffee**

**59¢** SAVE 16¢ WITH THIS COUPON AND \$10.00 PURCHASE

Limit one bag per customer. Effective thru Tues., April 22.

**WE NOW HAVE 4 BARBERS**

Our Newest is  
**Rick Johnston**  
And Our "Regulars" Dan-Mel & Jerry

**We Carry RK Products**

- Regular Haircuts • Ladies Haircuts
- We cut and style all long hair and specialize in Children's haircuts

**Mel's Golden Razor**

**595 FOREST, PLYMOUTH**

**455-9057** APPOINTMENTS WELCOME

**HOURS:**  
8:30 to 6:00  
Sat. to 4:00  
Closed Monday

# SC board nixes advisory ballot question

By DENNY COFFMAN

LIVONIA—An attempt by a Schoolcraft College trustee to place an advisory question concerning the board of trustees' composition on the June 6 ballot failed to gain the board's approval at its April 16 meeting by a 3-3 vote.

In a lengthy statement, Rosina Raymond asked that voters be given an opportunity to decide how many persons ought to serve on the board and the manner in which they should be elected.

Mrs. Raymond said the results would be used as a basis for the board's recommendation to the State Legislature on how its members should be elected.

The board of trustees now consists of eight persons elected at-large by the voters in each school district served by the college—Livonia, Plymouth, Garden City, Northville and Clarenceville.

AT PRESENT, SC's board composition is determined by a 1971 court order requiring all eight members be elected at-large. Previously, one from each school district was elected and three were elected at-large.

A legislative act would be required to change to a seven-member board or to change the method of election from at-large to by-district.

The basis for the court order was that by-district membership violated the one-man, one-vote concept.

Mrs. Raymond asked the board to approve the concept of placing the matter before SC district voters June 6, when they will also vote for two trustee seats—one, to replace John LaRue who is not seeking reelection, and the other held by Ron Cowden who is seeking reelection.

It had been suggested that one of the vacated seats be left unfilled, thereby automatically reducing the number to seven. It was pointed out, however, that this would be unconstitutional because it is a legislative prerogative.

"Now, it would seem timely that the Legislature act and that it have some advisory input before that action," Mrs. Raymond's statement read. "This advisory input could come from a majority of the trustees or from the voters in the respective districts. Any action would be merely advisory, the Legislature must make the final determination."

"Trustees come and go," she said, "but this is a people's college. I trust the people."

COWDEN, however, claimed there is insufficient time between now and the election for voters to familiarize themselves with all aspects of the issue.

"I would hope for some kind of educational process," said Cowden. Trustee Nancie Blatt agreed.

Mrs. Raymond's proposal would have asked voters to decide the following: • Shall the Schoolcraft Board of Trustees be composed of seven members? • Shall it be composed of nine members? • Shall members be elected at-large? • Shall they be elected from equally apportioned districts?

If the Legislature, under board urging, were to decide in favor of apportionment, districts would be established by the Legislature.

All community colleges in the state have seven-member boards, with the

exception of Delta College in the Bay City-Saginaw area.

MOST OF THE board members favor seven. However, Trustee Gerald Cox offered reasons for a nine-member board.

"We should not be fearful of being different," said Cox. "An advisory vote by our constituents would be helpful to us. I think another position on the board may help generate con-

trovery. Power corrupts and perhaps we have to be reminded that it's our constituents who make up the college."

Mrs. Blatt said she saw no problem with a nine-member board, either, although she said seven members would be less complicated.

Trustee Leroy Bennett agreed a nine-member board would have too many "ramifications," and that "the

closer we are to other community colleges, the better."

Mrs. Raymond accused the board of being "ivory towerish" in not seeking an advisory vote.

However, the trustees voted down her request for an advisory vote, with Mrs. Raymond, Cox and Trustee Paul Kadish voting in favor and Mrs. Blatt, Cowden and Bennett opposing. Trustee Arch Vallier was absent.

## Area Deaths, Funerals

### POVILAS LELEIKA

Services for Mr. Leleika, 74, of 14215 Lenore, Redford Township, were held in Divine Providence Lithuanian Catholic Church with the Rev. Kris officiating. Burial was in Holy Sepulchre Cemetery.

He was a retired McLouth Steel Corp. employe.

Survivors include his widow, Ursula; a daughter, Mrs. Stase Narbutas; and two grandchildren.

### RONALD H. SHOWERS

Services for Mr. Showers, 44, of 19196 Osmus, Livonia, were held in the R.G. & G.R. Harris Funeral Home with the Rev. Frank Cowick officiating. Burial was in Franklin Cemetery.

Mr. Showers was in the grocery business.

Survivors include his widow, Ann; daughter, Janice; son, Steven; brother, John; and sister, Mrs. Elaine Marbar.

### DOROTHY BAUMGARDNER

Services for Mrs. Baumgardner, 55, of Coldwater, Mich., who died April 9, were held in the Rosenberg Funeral Home with the Rev. Troust officiating. Burial was in Prairie Valley Cemetery, Centerville.

Mrs. Baumgardner, a former resident of Livonia, had worked as both a nurse and cosmetology instructor.

She is survived by her husband, Keith; daughter, Mrs. Carol Mahafak of Livonia; son, Eugene LeClair of Cheboygan; brother, Edward DeCaire of Coldwater; and eight grandchildren.

### OID MURRAY

Services for Mr. Murray, 85, of Inkster, who died April 11, were held in the R.G. & G.R. Harris Funeral Home with the Rev. Jerome K. Smith officiating. Burial was in Parkview Cemetery.

Mr. Murray was a carpenter. He is survived by sons, Roland, Gordon and Ovid Jr.; daughter, Mrs. Pauline Holder; sisters, Mrs. Edna Kemp, Mrs. Florence Kaake and Mrs. Mabel Durfee of Livonia; brother, George; and 12 grandchildren.

### EDWARD A. MARSCHALL

Services for Mr. Marschall, 26, of 446 Brandt, Garden City, who died April 15, were held in the R.G. & G.R. Harris Funeral Home with the Rev. James M. Morgan officiating. Burial was in Cadillac Memorial Gardens.

Mr. Marschall suffered fatal stab wounds in an April 15 incident. He was a fork lift operator.

He is survived by his widow, Barbara; daughters, Christina and Angela; parents, Mr. and Mrs. Anthony Marschall; brothers, Larry and Anthony Jr.; and sister, Mrs. Linda Ehrhart.



# FREE 1975 CAR

**1st PRIZE CHOICE OF A NEW GREMLIN, PINTO, OR VEGA!**  
 (FILL IN COUPON AND TAKE IT TO YOUR NEAREST ARNOLD'S)  
 DURING OUR SPRING GIVE-AWAY SALE THRU APRIL 26

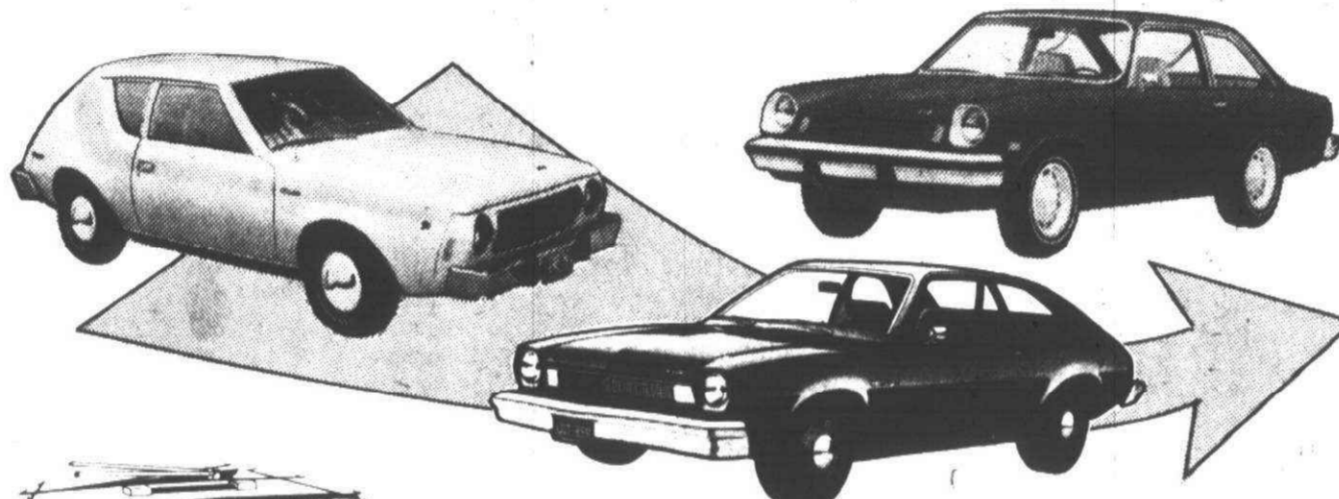

**3 1975 MODEL G.E. PORTABLE 10" COLOR TELEVISION SETS GIVEN AWAY AS 2nd, 3rd & 4th PRIZES**

FILL OUT COUPON & DELIVER TO ARNOLD'S DRUGS  
 Arnold's employees and Families not eligible. Odds depend on number of entries. No purchase necessary.

**ARNOLD'S MAXI SPRING GIVE-AWAY**  
 1st PRIZE - NEW CAR! 2nd, 3rd and 4th PRIZES - G.E. 10" PORTABLE COLOR TV SET

Name \_\_\_\_\_  
 Address \_\_\_\_\_  
 City \_\_\_\_\_  
 Zip \_\_\_\_\_ Phone \_\_\_\_\_

\*Low Line, Standard Equipment Only. You Must be 18 Yrs. Old to Qualify. Winners will be notified By April 30

MAXI DISCOUNT COUPON

1 1/2 Lb. Family Style Sliced COUNTY FAIR WHITE BREAD

**3/\$1.00**

LIMIT 3 PER CUSTOMER WITH COUPON THRU APRIL 26

MAXI DISCOUNT COUPON

1/2 Gallon LOW FAT MILK

**2/98¢**

LIMIT 2 PER CUSTOMER WITH COUPON THRU APRIL 26

MAXI DISCOUNT COUPON

Ladies One Size Fits All PANTY HOSE

**3/\$1.00** Reg. 77¢ Ea.

LIMIT 3 PER CUSTOMER WITH COUPON THRU APRIL 26

MAXI DISCOUNT COUPON

Spalding Practice 3 PACK TENNIS BALLS

**\$1.59** Reg. \$1.99

LIMIT 1 PER CUSTOMER WITH COUPON THRU APRIL 26

MAXI DISCOUNT COUPON

3-in-Pak G.E. or NORELCO FLASH CUBES

**79¢** Reg. \$1.19

LIMIT 1 PER CUSTOMER WITH COUPON THRU APRIL 26

MAXI DISCOUNT COUPON

13 Oz. Arnold's POTATO CHIPS

**65¢** Reg. 89¢

LIMIT 1 PER CUSTOMER WITH COUPON THRU APRIL 26

MAXI DISCOUNT COUPON

G.E. 1000 WATT HAIR DRYER

**\$19.88** Reg. \$24.88

LIMIT 1 PER CUSTOMER WITH COUPON THRU APRIL 26

MAXI DISCOUNT COUPON

Corning See-Thru ELECTRIC PERC

**\$8.88** 8-Cup Reg. \$12.99

LIMIT 1 PER CUSTOMER WITH COUPON THRU APRIL 26

MAXI DISCOUNT COUPON

Johnson & Johnson COTTON BALLS

**77¢** 230's Reg. 97¢

LIMIT 1 PER CUSTOMER WITH COUPON THRU APRIL 26

MICHIGAN BANKAMERICARD WELCOME HERE

master charge THE INTERBANK CARD

**MASTER CHARGE and BANKAMERICARD ACCEPTED**

DISCOUNT PRESCRIPTIONS



<b>BLOOMFIELD HILLS</b> 2540 N. Woodward & Square Lake 338-7191	<b>CLAWSON</b> 14 Mile and Crooks (Clawson Center) 435-2410	<b>FARMINGTON</b> 33322 W. 12 Mile Rd. 476-2110
<b>LIVONIA</b> 36642 Five Mile Rd. at Levan 425-8600	<b>SOUTHFIELD</b> 26960 Lahser Rd. at 11 Mile 353-5244	<b>TROY</b> 16 Mile & Dequindre 689-1051
		<b>WAYNE</b> 150 S. Wayne & Cherry Hill 728-5200

# BREVITIES

## PIONEER CONCERT

April 22— Pioneer Middle School's band and orchestra will perform "A United Nations Concert" at 8 p.m. Music from several countries will be

performed. The public is invited. There is no admission charge.

## CARDS AND LUNCH

April 22—Plymouth Chapter 115 Order of the Eastern Star will hold its

Spring Luncheon and Card Party at the Masonic Temple on Penniman Avenue at 12:30 p.m. Tickets for the luncheon and card party are \$2.50. Cost of the lunch alone is \$1.75.

## CHESS CLUB

April 22— The Chess Club, sponsored by the Plymouth Department of Parks and Recreation, will meet at 7:30 p.m. in the Plymouth Cultural Center, 525 Farmer. The club is open to novice and experienced players.

## PAINT FOR FUN

April 22— All beginners in oil painting are invited to an informal approach to the art from 1 to 3 p.m. in the Plymouth Cultural Center. There is no fee. For further information, contact the Plymouth Department of Parks and Recreation.

## PLYMOUTH COMMUNITY CHORUS

April 23— All interested persons are invited to sing with the Plymouth Community Chorus, which will meet at East Middle School, 1042 S. Mill. For further information, contact the Plymouth Department of Parks and Recreation.

## INDIAN MAIDENS

April 23— A "pow wow" for all Plymouth and Canton residents interested in joining a new mother-daughter group, Indian Maidens, will be held from 7 to 8:30 p.m. in the West Middle School cafeteria. Sponsored by the Canton-Northville-Plymouth YMCA, Indian Maidens is designed for girls six to nine years old and their mothers. The group meets once every two weeks to learn Indian lore and to enrich parent-child relationships.

## RETIRED PERSONS

April 23— The Plymouth-Northville Chapter of the American Association of Retired Persons (AARP) will hold its monthly meeting at 1:30 p.m. and a special activity for knitting and crocheting enthusiasts at 10 a.m. in the Plymouth Presbyterian Church. Members should bring sack lunches. Lap robes and other knitted items members are making for convalescent home residents will be displayed at 10 a.m. The meeting will feature a sing-along session and a speech by a representative of Awrey Bakeries on how a modern bakery operates. Visitors age 55 or older are welcome at all meetings.

## MAYFLOWER GARDEN CLUB

April 24—The Mayflower Garden Club will meet at 10 a.m. in June McKenny's, 9320 Ivanhoe. Co-hosting will be Rosemary Norquist. The meeting will feature a presentation on the use of shells for decoration.

## FOLK DANCE CLUB

April 24— The Plymouth Folk Dance Club will meet at 7:30 p.m. in Bird Elementary School, 220 Sheldon. The club is open to all who like to dance. A performance group is being planned.

## PARTY BRIDGE

April 24— Bridge enthusiasts will meet from 1 to 5 p.m. in the Plymouth Cultural Center, 525 Farmer.

## PILGRIM TOWERS UPDATE

April 25— Jim Houk, president of the Pilgrim Non-Profit Housing Corp., will speak on the "update of Pilgrim Towers" at 10 a.m. at the Plymouth Cultural Center, 525 Farmer. The speech is part of the monthly senior invitation meetings. Everyone is invited.

## CHARTER TOWNSHIP OF CANTON Zoning Board of Appeals

Notice is hereby given that a special meeting of the Zoning Board of Appeals will be held on Wednesday, April 30, 1975 at 7:30 P.M. at 128 Canton Center Road to consider the following items:

- To consider a request of the Fellows Creek Golf Course for a variance in the Fence Ordinance.
- To consider a request for the use of property at 41500 Ford Road.
- To consider the request of the S.S. Kresge Company for a delay in the installation of a sidewalk in front of 41425 Joy Road.
- To consider a request for a variance for a shopping center sign for Harvard Square Shopping Center located at the northeast corner of Sheldon and Ford Roads.
- To consider a request for a variance in the Sign Ordinance from the Monarch-Richter Building Company.
- To consider a request of Sunnyside Homes Inc. for a variance in the Sign Ordinance.
- To consider a request from Richard Kaiser for a variance in the Fence Ordinance at 1244 Lotz Road.
- To consider a request from the Chatsford Building Company for a variance in the Sign Ordinance.
- To consider the request of the Galaxie Metal Finishing Company for permission to establish a nickel and chrome plating factory at 3700 Morton Taylor Road.
- To consider a request to keep horses at 2292 Lilley Road.
- To consider any other business that may come before the Board.

JOHN W. FLODIN  
Clerk

Publish: April 21, 1975

## BIRD SCHOOL FAIR

April 25— Bird Elementary School, 220 Sheldon, will hold a fair from 5:30 to 8:30 p.m. Games, prizes, a magic show, a hot dog dinner and helium balloon contest will be featured.

## RUMMAGE, BAKE SALE

April 26— The East Middle School PTSO is sponsoring a rummage and bake sale from 10 a.m. to 4 p.m. in the school cafeteria.

## SANDBOX FILL

April 26—The Plymouth Jaycees are sponsoring a sandbox fill all day Saturday. Cost of the sand is \$1 per wheelbarrow and orders should be placed by April 25. For further information contact Mrs. Kathy Diesel, 277 Fair Street, Plymouth, or Mrs. Carol Galmeier, 35816 Dover, Livonia.

## RUMMAGE AND BAKE SALE

April 26—The Canton Township Jaycee Auxiliary is sponsoring a Rummage and Bake Sale at 44310 S. Umberland Circle between 10 a.m. and 5 p.m. Umberland is located between Warren and Ford roads off of Sheldon. For further information contact Carol Milosh, 44310 Umberland Circle.

## CHILDREN'S MOVIES

April 26— Children's movies will be shown from 10 a.m. to noon in the Plymouth Cultural Center. Admission is free. Hot dogs and cola will be available.

## STAMP SHOW

April 26, 27— The West Suburban Stamp Club will hold its annual exhibition on April 26, from 10 a.m. to 9 p.m. and on April 27, from noon to 6 p.m. in Central Middle School. The club's annual support of the Shriner Crippled Children's Hospital stamp distribution program will highlight the show. Stamp donations may be brought to the door or mailed to Richard Chellevoid, 40 S. Staebler, Ann Arbor, Mich./48103. The exhibit will feature junior, collector and championship displays.

## WEDDING MUSIC

April 27— Our Lady of Good Counsel Church will sponsor "An Evening of Wedding Music" at 7:30 p.m. in the church, 1160 Penniman. The program will include vocal solos, hymns and instrumental selections appropriate for weddings. Organ music will include marches suitable for wedding processions. Couples contemplating marriage and persons of all faiths are invited. The program is free.

## ARTS AND CRAFTS FAIR

April 27— The Western Wayne County Conservation Association will sponsor an Arts and Crafts Fair from 11 a.m. to 6 p.m. at the association's clubhouse, 6700 Napier, Plymouth Township. Various crafts will be displayed, and the snack bar will be open. Admission is free.

## SCHOOL REGISTRATION

April 28-May 2— Pre-registration for Truesdell and Central elementary schools will take place from 1 to 3 p.m. all week. Parents registering their children should bring a birth certificate. For further information call either school.

## OIL PAINTING & ACRYLICS

April 28, 29— An oil painting and acrylics session for persons with some experience will be held April 28 from 10 a.m. to 1 p.m. in the Plymouth Cultural Center. An evening session for advanced artists will be held on April 29 in the Cultural Center. The sessions are free, and local artists will be on hand for assistance.

## ICE SHOW

May 2, 3, 4— The ice show "A Change of Pace" will be held on May 2 and 3 at 7:30 p.m. and on May 4 at 3 p.m. at the Plymouth Cultural Center. Advance tickets, priced at \$2 for adults and \$1 for children and senior citizens, are available at the Cultural Center. Tickets at the door are an additional 50 cents.

## ALETA SCHOOL OF BALLET

CLASSICAL BALLET-CECCHETTI METHOD  
BEGINNERS -INTERMEDIATE -ADVANCED  
SMALL CLASSES AND PRIVATE LESSONS

45797 W. Ann Arbor Trail, Plymouth 453-7059

## CHARTER TOWNSHIP OF CANTON Invitation to Bid

Notice is hereby given that sealed bids will be accepted until 8:00 P.M. on May 13, 1975 at 128 Canton Center Road for the following:  
Installation of chain link fence around the D.P.W. property at 44508 Geddes Road.  
Specifications and information on the installation is available at the Township Offices at 44508 Geddes Road.  
The Township reserves the right to accept or reject any or all bids, and to waive any defects or irregularity in the proposal if it appears advantageous to the Township to do so.

JOHN W. FLODIN, Clerk

Publish: April 21, 1975

## NOTICE TOWNSHIP OF PLYMOUTH

Dog Licenses are due prior to June 1, 1975 and are available at the Plymouth Township Hall, Treasurer's office, 42350 Ann Arbor Road, Plymouth, Michigan, Monday through Friday, 8:30 A.M. to 5:00 P.M.

Licenses prior to May 31, 1975 \$3.00  
Licenses after May 31, 1975 \$5.00

Dogs must have a current rabies vaccination and owners must show proof of vaccination when obtaining dog licenses. Owners of all dogs not vaccinated and licensed before June 1 will be subject to violation tickets. Please remember you are also in violation if your dog is permitted to run at large or its frequent whining, barking, yelping or howling shall cause serious annoyance to the neighborhood or to persons passing to and fro upon the public highway.

JOSEPH H. WEST  
Plymouth Township Treasurer

Publish: March 31, April 21, May 12, 1975

## NOTICE OF PUBLIC HEARING ZONING BOARD OF APPEALS CITY OF PLYMOUTH MICHIGAN

At a meeting of the Zoning Board of Appeals to be held in the Commission Chamber of the City Hall on Thursday, May 1, 1975, at 7:30 P.M., a public hearing will be held to consider the following:

APPEAL NO. 75-8 - JOHN ADAMS of 644 Jener Street, Plymouth, requesting permission to construct an addition to the side of the house within seven (7) feet, six (6) inches of an existing garage at above address, which is in conflict with Article XV, Section 5.194(4) of Chapter 52, Zoning, of the Plymouth City Code.

Section 5.194(4) provides, in part, that no detached accessory building shall be located closer than twelve (12) feet to any main building.

All interested parties will be given an ample opportunity to participate in the hearing and, at the close of said hearing, all comments and suggestions of those citizens participating will be considered by the Zoning Board of Appeals, prior to rendering its decision.

PAUL V. BRUMFIELD  
City Clerk

Publish: April 21, 1975

## CHARTER TOWNSHIP OF CANTON Board Proceedings

A regular meeting of the Township Board of the Charter Township of Canton was held on Tuesday April 8, 1975 at 8:00 P.M.

The meeting was called to order by Supervisor Greenstein.  
Members Present: Greenstein, Flodin, Parsell, Myers, Poole, Schwall  
Members Absent: Cheske

A motion was made by Schwall and supported by Poole and unanimously carried that the Minutes of March 4, 1975 be approved.

A motion was made by Schwall and supported by Myers and unanimously carried that the Minutes of March 11, 1975 be approved.

A motion was made by Parsell and supported by Myers and unanimously carried that the Minutes of March 18, 1975 be approved.

A motion was made by Poole and supported by Schwall and unanimously carried that the Minutes of March 25, 1975 be approved.

A motion was made by Flodin and supported by Poole and unanimously carried that the Treasurers Report be approved as presented.

A motion was made by Parsell and supported by Schwall that the request from the Wayne County Road Commission for a drainage agreement in connection with the development of Franklin-Palmer Estates Subdivision be tabled:

Yes: Parsell, Myers, Schwall  
No: Greenstein, Flodin, Poole  
Motion Failed.

A motion was made by Poole and supported by Flodin that the Supervisor and Clerk be authorized to sign at their discretion the drainage agreement in connection with the development of Franklin-Palmer Estates Subdivision.

Yes: Greenstein, Flodin, Poole  
No: Parsell, Myers, Schwall  
The Motion Failed.

A motion was made by Schwall and supported by Myers and unanimously carried that the Township accept for maintenance the Sanitary Sewer Extension in connection with Canton Colony Multiple Development.

A motion was made by Schwall and supported by Flodin and unanimously carried that approval be given to the site plan of First Federal Savings at the corner of Ford and Haggerty subject to the removal of the free standing sign and approval of the landscape plan.

A motion was made by Parsell and supported by Myers and unanimously carried that approval be given to Plan 9B for McIntyre Manor Subdivision and the Sheldon Road-Cherry Hill interceptor and further that the sanitary sewer program proceed through the Canton-Van Buren Sewer and Water Authority.

A motion was made by Parsell and supported by Myers and unanimously carried that the month of May be declared Fix-Up Clean-Up month and all Canton citizens be urged to participate.

A motion was made by Parsell and supported by Poole and unanimously carried that the Canton Township Jaycees be given permission to hold their second annual Jaycee Fair July 29, 1975 through August 2, 1975 at the southeast corner of Ford and Lilley.

A motion was made by Parsell and supported by Myers and unanimously carried that no further building permits be issued within McIntyre Manor Subdivision until such time as detailed study is made to define the actual flood plain elevation and floodway of the Fellows Creek or improvements are made to the Fellows Creek in this area that would relieve the suspected flood problem.

A motion was made by Parsell and supported by Myers and unanimously carried that John Cojei and Fred Migaldi be appointed to the Canton Township Bi-Centennial Commission.

A motion was made by Poole and supported by Flodin and unanimously carried that the Township go on record as being opposed to proposed House Bill No. 4567 which relates to minimum tax rates for the County.

A motion was made by Poole and supported by Myers and unanimously carried that the Township express its opposition to the contemplated water and sewer rate increases to the outlying communities as proposed by the City of Detroit.

A motion was made by Myers and supported by Poole and unanimously carried that Commissioner Royce Smith be requested to try to obtain an overhead flashing light on the corner of Sheldon and Hanford Roads to aid the school children in crossing Sheldon Road.

A motion was made by Poole and supported by Parsell and unanimously carried that the Clerk be instructed to place notice in the Township newspaper informing property owners that sewer and water assessments are \$5.00 per front foot for water and \$9.00 per front foot for sewer and may be paid prior to connection to the system.

A motion was made by Parsell and supported by Myers and carried that the Supervisor and Clerk be authorized to sign at their discretion the proposed Storm Drainage Agreement with the Wayne County Road Commission and the Township in connection with the development of Franklin-Palmer Estates Subdivision.

Yes: Greenstein, Flodin, Parsell, Myers, Poole  
No: Schwall

A motion was made by Poole and supported by Schwall and unanimously carried that bills in the amount of \$141,878.62 be paid.

A motion was made by Poole and supported by Schwall and carried to adjourn.

ROBERT GREENSTEIN, Supervisor

JOHN W. FLODIN, Clerk

Publish: April 21, 1975

## ADD A PATIO or DRIVEWAY

Do it yourself—We will help you lay out your concrete job—and will loan you some tools.

PLAN A We will give you the name of a local cement contractor

PLAN B

Either way you get Quality TransIt Mix Concrete

### DELTA CONCRETE inc.

600 JUNCTION AVE. (Off Sheldon Rd., S. of 5 Mile) PLYMOUTH  
GL 3-3235

## CHARTER TOWNSHIP OF CANTON Board Proceedings

A special meeting of the Township Board of the Charter Township of Canton was held on April 1, 1975 at 8:00 P.M. at 128 Canton Center Road.

Members Present: Greenstein, Flodin, Parsell, Cheske, Myers, Poole, Schwall.

Members Absent: None

The meeting was a joint meeting of the Township Board and the Planning Commission.

The formation of the proposed Citizens Advisory Council and the composition of its membership was discussed.

The Waldenwood retreat scheduled for April 4, 5, and 6 was discussed and the agenda formulated.

ROBERT GREENSTEIN, Supervisor

JOHN W. FLODIN, Clerk

Publish: April 21, 1975

## NOTICE OF PUBLIC HEARING ZONING BOARD OF APPEALS CITY OF PLYMOUTH, MICHIGAN

At a meeting of the Zoning Board of Appeals to be held in the Commission Chamber of the City Hall on Thursday, May 1, 1975, at 7:30 P.M., a public hearing will be held to consider the following:

APPEAL NO. 75-7 - DAVID & SHARON RUCINSKI of 1132 Ross Street, Plymouth, requesting permission to construct an addition to the rear of the house within ten (10) feet of an existing garage at above address, which is in conflict with Article XV, Section 5.194(4) of Chapter 52, Zoning, of the Plymouth City Code.

Section 5.194(4) provides, in part, that no detached accessory building shall be located closer than twelve (12) feet to any main building.

All interested parties will be given an ample opportunity to participate in the hearing and, at the close of said hearing, all comments and suggestions of those citizens participating will be considered by the Zoning Board of Appeals, prior to rendering its decision.

PAUL V. BRUMFIELD  
City Clerk

Publish: April 21, 1975

## NOTICE OF PUBLIC HEARING ZONING BOARD OF APPEALS CITY OF PLYMOUTH, MICHIGAN

At a meeting of the Zoning Board of Appeals to be held in the Commission Chamber of the City Hall on Thursday, May 1, 1975, at 7:30 P.M., a public hearing will be held to consider the following:

APPEAL NO. 75-9 - CHARLES J. HEARD of 175 Amelia Street, Plymouth, requesting permission to construct a 30 ft. x 24 ft. garage to replace present 30 ft. x 18 ft. garage in rear yard at above address, which is in conflict with Article XV, Section 5.194(3) of Chapter 52, Zoning, of the Plymouth City Code.

Section 5.194(3) provides, in part, that the floor area of an accessory building intended to serve as a two car garage shall not exceed 528 square feet.

All interested parties will be given an ample opportunity to participate in the hearing and, at the close of said hearing, all comments and suggestions of those citizens participating will be considered by the Zoning Board of Appeals, prior to rendering its decision.

PAUL V. BRUMFIELD, City Clerk

Publish: April 21, 1975

## CHARTER TOWNSHIP OF CANTON Board Proceedings

A special meeting of the Township Board of the Charter Township of Canton was held on Wednesday April 2, 1975 at 8:00 P.M. at 128 Canton Center Road.

The meeting was called to order by Supervisor Greenstein.  
Members Present: Greenstein, Flodin, Parsell, Cheske, Myers, Poole, Schwall  
Members Absent: None

A motion was made by Parsell and supported by Flodin and carried that final plat approval be given to Canton Industrial Park and the Clerk be instructed to sign the plat.

Yes: Flodin, Parsell, Myers, Poole.  
No: Greenstein, Cheske, Schwall.

A motion was made by Parsell and supported by Poole and unanimously carried that the Township Board approve the concept of an intergovernmental recreation authority and appoint E. Brian Schwall as the Canton Township Representative.

A motion was made by Cheske and supported by Schwall and unanimously carried that the following schedule of fees be adopted as sign permit fees.

Schedule of Fees:  
Temporary Sign - \$30.00  
Permanent Sign - \$40.00

A motion was made by Cheske and supported by Schwall and unanimously carried that the firm of Seidman & Seidman be appointed the Certified Public Accountants for the Township.

A motion was made by Cheske and supported by Myers and unanimously carried that the Township appeal the decision of the court regarding Sheriff protection for the Township and also approve the change of attorneys to Travis, Warren, Nayer and Burgoyne.

A motion was made by Schwall and supported by Flodin and unanimously carried that the Township appropriate \$200.00 to the Bi-Centennial Commission.

A public hearing was held to discuss the proposed Consumer Protection Agency Ordinance. There was much discussion on the proposed ordinance.

A motion was made by Parsell and supported by Cheske and carried that a second public hearing be held at a future date on the proposed Consumer Protection Agency ordinance.

Yes: Flodin, Parsell, Cheske, Myers, Poole, Schwall.  
No: Greenstein.

A motion was made by Cheske and supported by Schwall and unanimously carried that the meeting be adjourned.

JOHN W. FLODIN  
Clerk

Publish: April 21, 1975

# "BINGO"

Livonia Post 3941 V.F.W.

- Every Tuesday
- Open 6:00 p.m.

27555 Grantland  
W. of Inkster Rd.  
261-4490 or GA 2-9865

# Residents named to EMS council

Twelve persons from western Wayne County are among those appointed to the Wayne County Emergency Medical Services (EMS) Advisory Council to help organize a paramedic-type rescue service throughout the county.

The EMS concept involves the training of rescue personnel, such as firefighters, police officers or ambulance

drivers, in life-saving medical techniques. The EMS crew is in contact by radio with a doctor stationed in an emergency room to advise what steps should be taken.

The advisory council was established in January during a meeting of various health authorities, public officials and private residents organized by the County Board of Health.

santia, St. Mary Hospital; and Sister M. Lauriana, Madonna.

The two Westland representatives on the advisory body are Westland Fire Chief Ralph Savini and Lt. William Roquemore of the Sheriff's Department.

The Plymouth representatives are Plymouth Fire Chief George Schöeneman and Plymouth Township Fire Chief James Gignac.

Tom Taylor (D-Westland) who whose district includes Garden City, and Royce E. Smith (R-Belleville) whose district includes Plymouth, Plymouth and Canton townships.

### PERSONS FROM Livonia named to the advisory council include:

Michael McGee, administrative aide, City of Livonia; Walter Heikka, St. Mary Hospital, Livonia; Kathryn Robinson, director of Emergency Medical Training program at Madonna College, Livonia; Rita Radzialowski, St. Mary Hospital; Harry Hayden; Carl Ward, senior captain, Livonia Fire Department; Sister Mary Cala-

THE COUNTY could qualify for up to 75 per cent federal funding.

Among the decisions advisors will recommend is whether revenue for the program will be administered by the county as a whole or by the various local communities involved.

Among the commissioners who nominated members to the advisory council are Mary Dumas (R-Livonia),

## Realtor Week scheduled

Public officials from communities in western Wayne County have joined in proclaiming April 20-26 as Realtor week and have urged residents to "join this observance with appropriate and significant programs of civic betterment."

Among those issuing the joint proclamation were Mayor James W. Lowe of Garden City, Mayor Edward H. McNamara of Livonia, Mayor Beverly McAnich of Plymouth, and Supervisor

Patrick J. McDonald of Redford Township.

The proclamation cited the 2,000 members of the Western Wayne Oakland County Board of Realtors (WWOCB) for "encouraging home ownership through its effort to match the needs of buyers with available homes, counsel both buyers and sellers, and guide them through the various steps necessary to complete the purchase."

Jerry J. Rozema of Livonia, president of the WWOCB, said special efforts would be made during the week by his organization to point out the benefits of house ownership and to study methods to aid owners hit by the economic slowdown.

## GOP women to hear leader of 'Stop ERA'

Mrs. Elaine Donnelly, Michigan chairman of the National Stop ERA Committee, will speak at a luncheon meeting of the Livonia Republican Women Thursday, April 24 in the Plymouth Elks Lodge, 41700 E. Ann Arbor Road, Plymouth.

The event will begin at 12 noon. Mrs. Donnelly recently called a demonstration before the Chatham Food Store at the Livonia Mall to protest the fact that Florida oranges were becoming a political football.

It was held to counter a demonstration held by ERA supporters urging a boycott of Florida fruit until Florida ratifies the Equal Rights Amendment.

Mrs. Donnelly asked women who oppose ERA to buy more Florida fruit and juices than ever.

"We want the Florida lawmakers to know that the women's liberation movement and feminist groups do not speak for the majority of Michigan women," she said.

"We don't think they should have to worry about Florida fruit and juice sales as they prepare to vote on ERA."

"We deplore this type of blackmail tactics. We prefer to debate the issues."

For lunch reservations contact Mrs. Corinne Snieder, 9296 Idaho, Livonia, before April 21.



LOUISE CUTLER, office manager of James C. Cutler Realty in Northville, has been named Realtor-Associate of the Year by Western Wayne Oakland County Board of Realtors (WWOCB). She is treasurer and director of WWOCB, chairs its finance committee and is an advisor to its education committee. A Realtor for eight years, she has been active in 4-H, PTA, League of Women Voters, Northville Women's Club and Business and Professional Women's clubs.

## Austin to talk to accountants

Richard Austin, Michigan's secretary of state, will speak to members of the American Society of Women Accountants Tuesday, April 22 in the Versailles ballroom of Hotel Pontchartrain, Detroit.

A certified public accountant himself, Austin will speak on "Certified Public Accountants' Responsibilities, Political and Social."

A reception for Austin will be held at 5:30 p.m., followed by dinner at 6:30 p.m. For reservations contact Donna M. Johnson, 19209 Auburndale, Livonia.

## Talk planned on self-defense

Officer Gerald Vandersloot of the Westland Crime Prevention Bureau will discuss self-defense concepts at a free seminar titled "Lady Beware" on Tuesday, April 22, at 7 p.m. at Schoolcraft College.

Sponsored by women's programs and services, the program will consider self-defense concepts for car, street and home situations.

Along with a film presentation, Vandersloot will demonstrate locks and simple safety devices that are easily installed in the home.

The seminar will meet in the Liberal Arts Theater.

**ADLER PRINTING CALCULATOR**  
Built for Office Use \$219.00  
**MARAGON BUSINESS MACHINES**  
26541 Plymouth Road  
937-8911  
Sales-Service-Rentals

**NORTHVILLE AUTO PARTS, INC.**  
116 E. Dunlap  
NORTHVILLE, MICHIGAN 48167  
348-9650  
IF WE DON'T HAVE WHAT YOU NEED, WE CAN GET IT!  
HRS. MON-FRI 8 A.M.-7 P.M. SAT. 8 A.M.-5 P.M. SUN. 10 A.M.-2 P.M.

**STEINKOPF'S**  
**ARBOR WEEK SPECIALS**  
Good Thru April 30th

8'-10' White Birch	\$19.95 Reg. 29.95	6'-8' Crimson King	\$9.95 Reg. 14.95
15'-18" Globe Yews	\$7.95 Reg. 10.95 & 12.95	8'-10' Silver Maple	\$10.95 Reg. 14.95
3'-4' Flowering Crabs	\$5.95 Reg. 8.95	3'-3 1/2' Taxus Capitata	\$9.95 Reg. 29.95

Free Yard & Garden Tips & pamphlets.

**20% OFF ALL Fruit Trees**

## Steinkopf Nursery

LIVONIA TRUE VALUE HARDWARE

### Cleaning Aids

Your Choice \$2.99

**KORDITE**

**TRASH AND GRASS BAGS**  
Forty 23-gal. bags in dispenser box. E3-4070

**HEAVY DUTY BAGS**  
Twenty 33-gal. bags in dispenser box. E3-2033

**RENT A SHAMPOOER**

for just \$1 a day with purchase of any size Blue Lustre Shampoo. Twin-brush shampooer has 75% more brush (both larger brush and more bristles) to clean faster, be easier to maneuver. Large tank. Blue Lustre Formula Shampoo—great for wall-to-wall machine or spot cleaning. Leaves no residue.

22 oz. Aerosol 1.98 1-Qt. 2.29  
1/2 Gal. .... 4.39 Gal. .... 6.98

**HANDY HELPERS**

(A) HOUSEHOLD HAND SPRAYER. Nozzle adjusts from fine mist to jet stream. See-thru jar. F-75TT..... 88¢

(B) TRU-TEST LIQUID DRAIN CLEANER. Dissolves grease and hair. 32 oz. .... 88¢

Self-Polishing WAX  
Seals and eases; slip resistant.  
27-Ounce Can. 35¢ ..... 1.89  
46-Ounce Can. 36¢ ..... 2.69

STAIN REMOVER  
Really lifts out difficult carpet stains easily merely spot and blot them away. 54 ..... 1.98

(E) PANEL MAGIC. Restores wood paneling beauty. Hides scratches. Pint. PM10 ..... 1.79

(F) GARAGE MAGIC. Cleans and degreases garage floor, patio, etc. Just spray on, hose off. Pint. GM88..... 1.79

**LIVONIA TRUE VALUE HARDWARE**

5 MILE ROAD at FARMINGTON ROAD

**True Value HARDWARE**

DINERS CLUB

PHONE GA 2-1155 — 937-1611

OPEN DAILY 9 a.m. - 9 p.m.  
SUNDAY 10 a.m. - 5 p.m.

**SCHMALZRIEDT SONS**  
Funeral Home  
16025 GRAND RIVER  
BETWEEN GREENFIELD and SOUTHWILD  
Dorinda C. Schmalzriedt, Luth. Mgr.

WE CONSIDER every family special, deserving extra special care at their time of need. And that's why we're here... to provide it.

**Channel Master Antennas and Rotors**

**TOP OF THE LINE QUANTUM SERIES**

<b>Metro</b> 1174 Quantum	Regular 124.95 Sale 98.88 SAVE \$26.07	\$98.88*
<b>Suburban</b> 4755 Quantum	Regular 139.95 Sale 108.88 SAVE \$31.07	\$108.88*
<b>Fringe</b> 1163 Quantum	Regular 149.95 Sale 128.88 SAVE \$21.07	\$128.88*

\*Price includes installation. Your new installation will include only the finest equipment.

DO-IT-YOURSELF KITS AVAILABLE—SAVE!!!

**T.V. AERIAL SUPPLY CO.**  
729-6460  
34645 Ford Rd., Westland  
Sales-Service-Installation  
UHF-VHF-TOWERS-ROTORS-INSTALLATION-REPAIRS-COMMERCIAL-RESIDENTIAL

# Bahamas out-island pleasure oriented

By SUE ROSIEK

TREASURE CAY, Bahamas—This 1,400-acre resort town is lavish. It offers just about everything you can think of—it's warm, quiet but exciting, and altogether pleasure oriented. Treasure Cay is on the Island of Abaco, the second largest of the 700 Bahama out-islands.

Even the trip to the cay, via Air Jamaica from Detroit to Nassau, and then Bahamasair to Treasure Cay, is delicious. The food and drink served during the Air Jamaica flight is fantastic, and the view of the clear blue, island-dotted Atlantic from the Bahamasair plane is breathtaking.

Accommodations in Treasure Cay, which is about a 50-minute flight from Nassau and directly east of Florida, are plentiful and very appealing. Visitors have a choice of staying in either the Treasure Cay Beach Hotel (the only one on the island) or in one of 50 villas.

THE VILLAS are all within walking distance of the hotel. In fact, everything on Treasure Cay is within walking distance. There are few modern distractions such as telephone, television or radio. Instead the lush tropi-

cal vegetation simply entices people to stroll around the resort, soak in its beauty and relax.

Treasure Cay has something for every type of vacationer, from the sports enthusiast to those seeking a quiet, sunny holiday.

For the active vacationer the resort has four clay tennis courts and a year-round tennis pro to help smooth out the rough edges to your game. Facilities for shuffleboard, volleyball, badminton and croquet also are available.

Water sports include sailing, water-skiing, scuba diving and swimming, in the ocean or in the hotel's olympic size pool.

THE REEFS make snorkeling an interesting possibility and the variety of sea life and crystal waters are great for underwater photography.

All of the Bahamas, and in particular Treasure Cay, offer some of the world's finest deep-sea fishing. The bone-fishing is so fantastic it can make you extend your vacation, my fisherman friends tell me.

For the vacation duffer there's a championship 18-hole golf course, tagged the best in the Bahamas.

If you're not in the mood for any of these there's always a walk on some 3½ miles of white-sand beaches, sampling goombay smashes or yellow birds on the shaded terrace at the hotel, or birdwatching.

DAY-LONG and afternoon excursions to other nearby cays are available through the hotel.

Our tour group of six, took an afternoon cruise to the nearby Guana Cay. With the cay's thatched roofs and circular paths shaded by palms it looked like a scene out of a Humphrey Bogart flick. This old world charm is just another interesting aspect of a Bahamian holiday.

Shopping is limited on Treasure Cay, souvenir hunters can purchase items in either the marina or hotel gift shops.

Two restaurants on Treasure Cay, in the hotel and the Spinnaker feature a delicious assortment of Bahamian dishes.

It's not any one of these that make Treasure Cay (pronounced key) a perfect vacation destination but a combination that make it everything a vacation should be.

TRAVEL ACCOMMODATIONS PROVIDED BY THE BAHAMAS TOURIST OFFICE



Garden path leads to pool at Treasure Cay Beach Hotel on Abaco; the beach is nearby (Staff photo by Sue Rosiek)

The Observer & Eccentric *The Good Life*

6A\*\* (F.L.P. 8A, R-4A, W, G-6A)

Monday, April 21, 1975

## Continental menu featured

# Atrium chef's Beef Wellington a specialty

By ETHEL SIMMONS

Beef Wellington for two at \$23 is the most expensive dinner on the menu at the Jarrus' elegant Atrium in Bingham Farms, but, ah, it's worth it.

Executive chef John Etchart is a Casque who describes himself as "a classic French cook."

Using the tines of a fork, he draws a map of France on a flour-covered porkboard in the Atrium kitchen. Etchart explains he does not specialize the cooking of any one area. He has worked in France, Spain,

Canada, Switzerland and Egypt and has served the Queen of England in Canada and the late King Farouk in Biarritz.

ETCHART WAS head chef at the five-star restaurant Le Dome in Fort Lauderdale when the Atrium's Jarrus spirited him away.

A working chef, Etchart is the kind of man who likes to do it himself instead of showing others. Nothing seems beneath him; he was seen dashing through the kitchen with a green

trash bag—taking out the garbage?—when we came to offer our compliments, after dining.

The Atrium is host Jarrus' third restaurant, and the only one he presently owns. He pays attention to every detail, including asking a bus boy whose hair had grown just a bit too long, to "get a haircut tomorrow."

The response was a respectful, "Yes, sir."

"I HAVE the same trouble with my boy," Jarrus said with a smile, afterward.

Jarrus came to the United States from Israel where all his family had been in the butcher business. He learned the art at age 12, and every once in a while Jarrus still likes to carve the rack of lamb.

"I like to cut meat," he explains. The Atrium is named for its tree-filled courtyard. The architect for the office building and restaurant wanted to leave open space, according to Jarrus, "but I offered to do the landscaping if we could have it rent-free."

LAST SUMMER the courtyard was used for cocktails and hors d'oeuvres, and this year an upcoming bar mitzvah party will use the atrium for dancing.

When will the courtyard be open? "Tomorrow! It depends on the weather," Jarrus says.

The Atrium's continental menu includes an insert of "Gourmet Dinners"—15 of these are rotated. For a low of \$6.75, you can have Chichen a la Princesse, breast of chicken in a champagne sauce, with white asparagus.

"A lot of people think we are high," Jarrus says, "but our price includes a complete dinner with fondue."

JARRUS ALSO points out, you can order for two or more persons any gourmet dish not on the menu. But call ahead, he warns.

The luncheon menu also has one of 15 inserts every day. Bobbies Pub next to the Atrium is part of the same



Executive chef John Etchart applies decoration to pastry and pate-covered beef tenderloin.

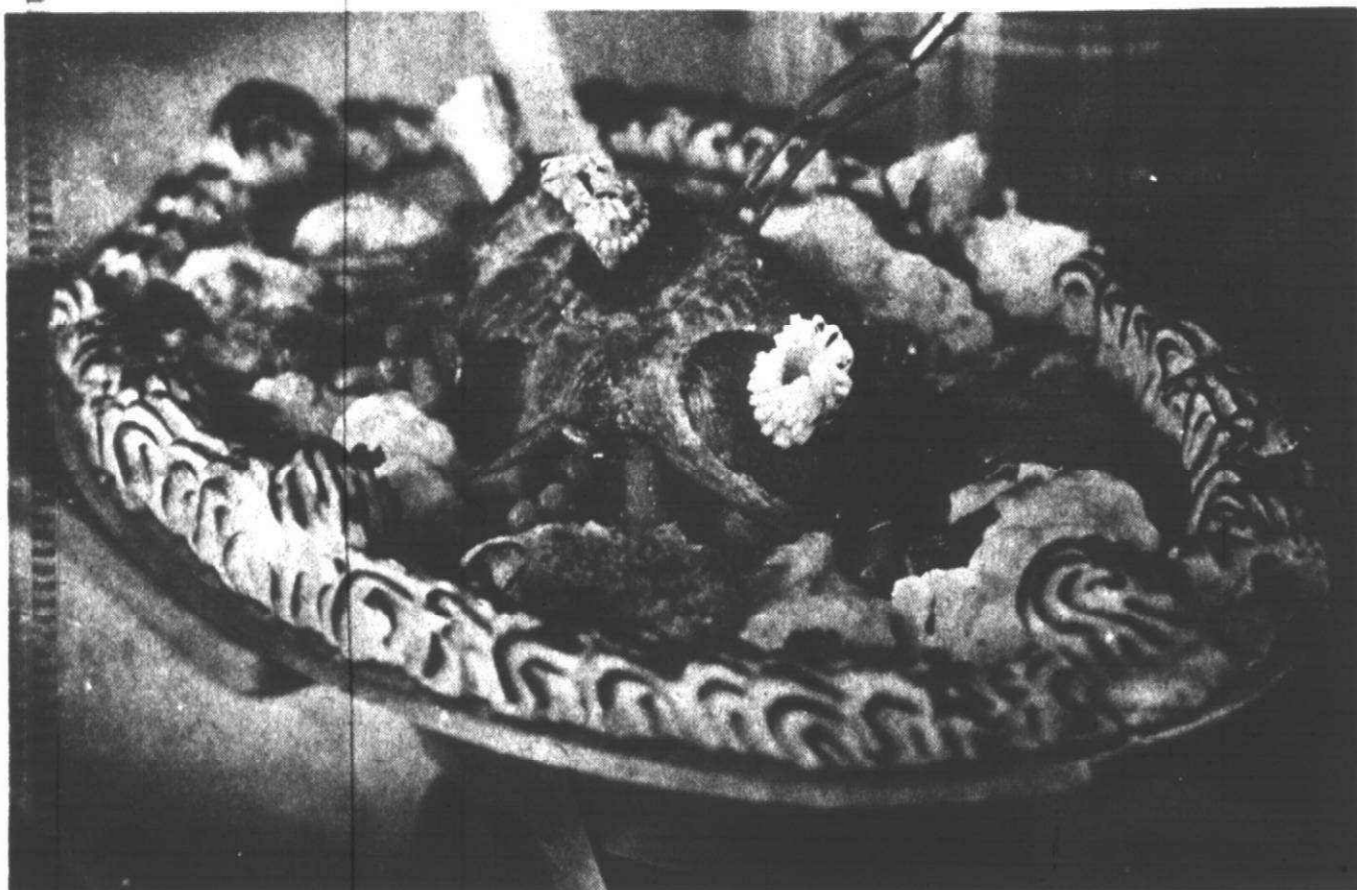

Beef Wellington is ready to serve, rimmed with duchess potatoes and garden vegetables (Staff photos by Barbara McClellan)

corporation and is a more casual spot for drinks and dining.

Chef Etchart's recipe for Beef Wellington is given below. He says it's easy to do, and if you want to save time, buy frozen puff pastry dough. Or you can make your own dough ahead of time and freeze, then thaw when needed. For the pate, you can find canned goose liver on supermarket gourmet shelves.

### BEEF WELLINGTON

Take out the center of a 20-ounce tenderloin.

Saute for 14 minutes till rare, then leave to cool for 15 minutes. During this time roll one pound puff pastry.

When dough is ready to use, take 8-

ounce goose liver and mix it with chopped mushrooms. Add one ounce of cognac and one ounce port. Mix them together and spread on top of the Wellington. Cover it with pastry dough.

Brush it with egg-wash. Put decoration on top, if desired.

Cook for a half hour at 350 degrees Fahrenheit.

Serve with truffle sauce accompanied by garnish.

### PUFF PASTRY DOUGH

2 pounds flour

1 quart water

2 ounces salt

Put flour in a bowl. Mix with water and two ounces salt. Mix them together. Let it rest for 20 minutes. After

that, roll into a sheet mixed with puff pastry margarine.

Roll puff crisscross six times; that is, fold it and roll it six times giving 15-minute intervals between rolling. Finally, roll it into one sheet, and it is now ready to use.

### TRUFFLE SAUCE

Chop two or three pieces of truffle and 16 ounces gravy and four ounces chopped goose liver and one ounce cognac. Mix them together and boil for 15 minutes.

### GARNISH

Small bouquet of garden vegetables, such as asparagus, cauliflower, carrots, nut potatoes, broccoli and broiled tomatoes.

# buy 2 save 25¢

in the popular  
28-oz. size

25¢

Worth 25¢  
on the  
purchase  
of two 28-oz.  
bottles of  
Uptown.

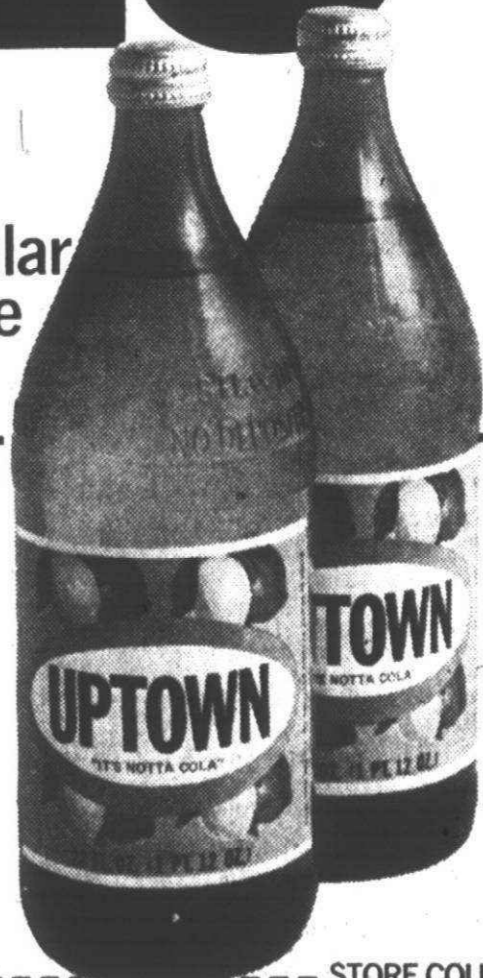

25¢

Stretch your food budget, enjoy the tangy, refreshing, lemon-lime goodness of Uptown and save! Buy two party-size bottles and the coupon entitles you to a generous 25 cents off the regular price.

TO DEALER: Your Uptown bottler Service-Salesman will pick up and redeem this coupon for 25¢ plus 3¢ for handling when it has been used as part payment for the purchase of 2 bottles of Uptown 28-oz. size. Invoices proving purchase of sufficient Uptown stock to cover coupons presented for redemption must be shown upon request. Void if prohibited, taxed or restricted. Cash value: 1/20 of 1¢. GOOD ONLY IN MICHIGAN. Offer expires July 31, 1975.

STORE COUPON

OE21

# Where There's Life

## FOR LISTINGS...

For event(s) to be listed for publication send at least one week in advance to Sue Rosiek, Wayne County Good Life Calendar Listing, Observer & Eccentric Newspapers, 36251 Schoolcraft, Livonia, 48150

"looks and sounds like a hit."  
Chuck Thurston, Free Press  
"a splendidly conceived and deftly executed multimedia effort."  
Bill Gray, News  
"I urge you to go see 'Personals'!"  
Shirl Harris, WQRS  
"damned good!"  
Jim Stanley, South End

## personals

A MUSICAL LOOK AT 200 YEARS OF PERSONAL AMERICA  
Dinner Theatre of Detroit  
Thursdays thru Sundays  
Mercy College, 8200 W. Outer Drive  
Reservations: 531-6131

## CHILDREN'S CHOICE

GREENFIELD VILLAGE PLAYERS PRESENT "RUMPELTILTSKIN" April 26 in the Henry Ford Museum Theater at 2 p.m. Tickets are \$2.25 for adults and \$1.25 for children 14 and under. To make group reservations, call the Travel and Convention Department at Greenfield Village, Dearborn.

ANIMAL EXHIBITS in Wonderland Center, Plymouth and Middle Belt roads, Livonia, now through April 30. Baby animals are featured.

## TALKING

DR. MARY CALDERONE, famed crusader for sex education in the school, will speak in Schoolcraft College Waterman Campus Center, April 22 at 8 p.m. Tickets are \$2 and available in the college bookstore and the night of the lecture.

# curtain time

THEATER GUILD OF LIVONIA-REDFORD stages "What the Butler Saw," April 25, 26, 27 and May 2, 3 in the playhouse, 15138 Beech Daly, just south of Five Mile, Redford Township. For reservations call Mrs. Gregory G. Nelson, 30742 Ann Arbor Trail, Westland, or Mrs. C. Foster, 16772 Country Club Drive, Livonia. Curtain time 8:30 p.m. on Fridays and Saturdays and 7:30 p.m. on Sundays.

THE THEATER of the University of Detroit-Marygrove College present "Arsenic and Old Lace" April 25, 26 and 27. Curtain time is 8:30 on Fridays and Saturdays and 7:30 p.m. on Sundays. Tickets at \$3 general admission and \$2 for students and senior citizens, are available in the Performing Arts box office.

"WALTZ OF THE TOREA-

DORS" opens in the Hilberry Theater, Cass and Hancock. The production continues in repertory until May 23. For complete ticket and schedule information call the Hilberry box office.

PROVIDENCE STAGE DOOR, the employe drama group at Providence Hospital, Southfield, presents "The Odd Couple" April 25, 26 at 8:30 p.m. in the Fisher Center Auditorium in the hospital, 16001 Nine Mile, Southfield. For tickets call the hospital.

WAYNE-WESTLAND CIVIC THEATER offers mystery-comedy "The Gazebo" April 25, 26 at 8:30 p.m. in John Glenn High School, 36105 Marquette between Ford Road and Cherry Hill. Tickets, at \$2.50 for adults and \$1.25 for students and senior citizens, will be available at the door.

**Hope's Fish & Chips**  
fresh Nova Scotia Fillets filleted in our kitchen  
Delicious Shrimp, Frog Legs, Clams, and Scallop Dinners  
(OUT OF THIS WORLD) Complete Dining Facilities  
28370 JOY ROAD  
IN SHOPPING PLAZA  
Bet. Middlebelt & Inkster  
CARRY-OUT ORDERS:  
CA 7-2130 or CA 7-2304

**TAKE A CHICKEN OUT TO DINNER**  
BONELESS ALMOND CHICKEN \$2.75  
3 Tender breasts of capon, dipped in egg batter and deep fried to a golden elegance, topped with crushed almond and served with our chicken gravy.  
**Susie Dong's** Phone: 477-0656  
33459 West 8 Mile Rd. Just W. of Farmington

**SANTA IS BACK**  
for **2 WEEKS ONLY**  
FREE, FREE, FREE  
GET ALL THIS WITH BIKE PURCHASE  
(OFF LIST PRICE)  
VISOR • HELMET • OIL  
LG GAS CAN • SPARK PLUG •  
RACE SHIRT • LG CHAIN OIL •  
SUZUKI CAP • SUZUKI KEY FOB •  
ZIPPER 3 POCKET VEST  
**TWO WEEKS ONLY**  
5 Acre Site  
26,000 Sq. Ft. Show  
Bike Franchise in Michigan  
The Largest Single  
**FDR**  
**CYCLE and SPORT, Inc.**  
455-7300  
41900 FORD ROAD, BETWEEN HAGGERTY & LILLEY PLYMOUTH  
Open Monday thru Friday 10-8 p.m. Saturday 9-7 Closed Monday

**TELEVISION SERVICE SPECIAL ONLY \$3**  
We will pick up your television set, bring it to our shop and have it checked by our TV experts. You will then be notified by telephone of the cost of repair. If you decide not to have it repaired we will return it to your home. All for only \$3.  
**COLOR ANTENNA AND ROTOR**  
Completely installed\*  
cash price \$2 week  
Normal installation \$98  
\*Normal installation \$98  
28915 JOY RD WESTLAND PHONE: 525-5450



DR. BARTOLO (David Gloff) tries to flirt with an uninterested Rosina (Nancy Fox Hoover). The pair will be in the Michigan Opera Theater's performance of "The Barber of Seville."

# CONCERTS

MICHIGAN OPERA THEATER AND THE PLYMOUTH SYMPHONY ORCHESTRA present "The Barber of Seville" April 26 at 8 p.m. in Plymouth Salem High School, Joy west of Canton Center Road. Tickets, at \$5.50 are available Monday through Friday 9 a.m. to 5 p.m. in the box office in the Edison office, Main Street at Ann Arbor Trail, Plymouth.

AN EVENING OF WEDDING MUSIC April 27 at 7:30 p.m. in Our Lady of Good Counsel Catholic Church, 1160 Penn-

man, Plymouth. Admission is free.

METROPOLITAN OPERA COMPANY presents Rossini's "L'Assedio di Corinto" (The Siege of Corinth) April 28 at 8:30 p.m. in Masonic Temple. Featuring Beverly Sills, Shirley Verrett, Harry Theyard, Justino Diaz and Thomas Schippers conducting. For more information contact the Detroit Grand Opera Association, 20 E. Jefferson, Detroit.

GOUNOD'S "ROMEO ET JULIETTE," with the Metropolitan Opera Company's Judith Blegen, Franco Corelli, Dominic Cossa, John Macurdy and Henry Lewis conducting April 29 at 8 p.m. in Masonic Temple. For tickets call the Detroit Grand Opera Association, 20 E. Jefferson, Detroit.

CLASSICAL SAXOPHONIST, Sigurd Rascher will play a benefit concert for the Waldorf Institute of Mercy College, Thursday, April 24, at 7:30 p.m. in the auditorium of Detroit Waldorf School, 2555 Burns. He will play pieces by Bach, Mozart and Hayden and modern composers.

EXHIBIT OF OIL PAINTINGS by Marie Robertson in the Farmington Public Library, 32737 Twelve Mile Road, Farmington Hills. Exhibit continues through April 30.

**Special Purchase Sale**  
**Men's 10 SPEED BICYCLE \$99.95**  
In the box or \*10 set-up Reg. \*169  
• Simplex prestige derailleur  
• Weinmann centerpull brakes  
• 27x1 1/2 wheels, quick release hubs  
• Lugged frame  
• Weight: 27 lbs.  
• Hutchinson gumwall tires  
• Alloy kickstand  
**BACKPACKS \$25**  
or \*20 with bike purchase  
• H-shaped aluminum frame, 16"x31"  
• Water repellent nylon  
• Divided top and bottom compartments, 15"x18"x7" Pin mounted frame  
• Many other features.  
• Available in yellow, blue, orange, green  
**3 Speed Ladies' Bicycle \$74.95**  
In the box or \*10 set-up \$85 with 10 speed bike purchase  
• 3 speed derailleur  
• 27x1 1/2 wheels with wing nut release  
• Stainless steel fenders  
• Weight: 27 lbs.  
• Hutchinson gumwall tires  
• Alloy kickstand  
**RECREATIONAL LEISURE CORP.**  
30717 W. TEN MILE ROAD • FARMINGTON  
Daily 9-6 Sat 9-4 477-0212 Just East of May's Mower

**21 ACRES OF FUN**  
ST. PETERSBURG BEACH, FLORIDA  
Something for every member of the family... Large white sand beach on the Gulf to the Intercoastal Waterway. Fine Dining, Shopping Center. First-run movie theatre. Live entertainment. Year 'round accommodations.  
For brochure and rates, write or call 813-360-7011  
**Happy Dolphin INN**  
4900 Gulf Boulevard  
St. Petersburg Beach, Fla. 33706

**PEPPERIDGE FARM**  
Thrift Shops  
**WE ARE OPENING SIX DAYS PER WEEK BEGINNING APRIL 21 FOR THE CONVENIENCE OF OUR CUSTOMERS**  
COME VISIT OUR **PRODUCT THRIFT SHOP**  
LOCATED AT 25187 W. 6 MILE, REDFORD, MICHIGAN  
ENJOY NEW ENGLAND THRIFT BREAD, ROLLS, COOKIES, STUFFING, AND FROZEN PRODUCTS  
STORE HOURS: MONDAY THRU FRIDAY 10 A.M. - 6 P.M. SATURDAY 10 A.M. - 5 P.M.

**PARTY PANTRY**  
CONVENIENCE STORE  
**LARGE SELECTION OF DOMESTIC AND IMPORTED BEER, WINE AND CHAMPAGNE**  
• Ice Cream • Snacks, Soft Drinks and Selected Grocery Products • Cigarettes and Tobacco Items • Drink Mixes • Health & Beauty Aids Items • Newspapers • Ice • Bakery Products • Cold Meats • Cold Beer • Party Accessories  
**THIS WEEK'S SPECIALS!**  
**McDONALD COTTAGE CHEESE** 16 OZ. **39¢ EA.**  
**KIRSCH SOFT DRINK** 10 FL. OZ. 6 PAK NR BTLs. **58¢**  
Root Beer - Cola - Orange  
**BAR TENDERS DRY MIXES** 6 OZ. WT. **79¢ ea.**  
— EVERYDAY LOW PRICES —  
**SOFTTEE WHITE BREAD** 36 oz. loaf **29¢**  
**ICE - 10 lb. BAG** **39¢**  
**FISHER SPANISH PEANUTS** 4 lbs. TIN **\$2.99**  
**OPEN 7 A.M. to 1 A.M. - 7 Days a Week**  
**45001 FORD ROAD AT CANTON CENTER ROAD AT THE NEW MEIJER THRIFTY ACRES**

# editorial opinion

## Mirto needs manners

Plymouth Community School Board Trustee Gary Mirto ought to learn tact. He apparently does not know the difference between a school board meeting and a court of law and between a concerned resident and a witness in a criminal trial. Mirto's behavior at last week's school board meeting, at which the controversial 45-15 program was discussed, was rude and downright obnoxious. The questions he asked concerning the year-round school calendar were perhaps legitimate. But the manner in which they were asked was not. Mirto's behavior was akin to a prosecuting attorney cross-examining a star defense witness, rather than that of a school board trustee as he played to a small audience of residents in opposition to the 45-15 plans. After asking strings of leading questions to fellow school board members, suggesting that the district's administration had submitted a recom-

mendation against 45-15, Mirto reached the height of rude officialdom when he cross-examined one resident of the Miller attendance area who exercised his first amendment right to speak in favor of the year-round program. Calling the resident from his seat, Mirto asked, "Will your children still attend Miller after the new elementary schools are constructed?" He implied that the resident's support was not fully legitimate. We find that question and that attitude highly offensive. Any resident in any school district or municipality in this county has the constitutional right to voice his feelings before elected officials without fear of public embarrassment or intimidation. Perhaps if other residents had not backed Mirto's implications against 45-15 and grunted low complaints while one lone resident was speaking, Mirto would not have been so brave. Especially since he had voted in favor of the pilot 45-15 program in February.



## The Stroller That reading problem

By W. W. EDGAR

Sitting at the luncheon table the other day waiting for the second cup of coffee, we got to discussing the word carried in the public prints that the reading problem that has been plaguing the public schools has now reached the college level, causing considerable concern among the educators. "What ever happened to the 'Three R's'?" one of the diners asked, and said that "readin', 'ritin' and 'rithmitic" were the foundation on which his education was built. While waiting for an answer, he asked, "How can the schools graduate anyone who hasn't learned to read and what happens to a fellow out in the business world who can't read?" Well, The Stroller had a partial answer. He recalled asking that question of one of the area's school superintendents a few months ago and was given a startling reply. "EACH ONE OF US has a level of intelligence above which we can't rise," he said, "and the boy in our

school who is being graduated, has reached that level, insofar as reading goes. "He is fine in other grades and classes, and it would be a burden on the taxpayers and unfair to him, if we forced him to remain in school—when we know now that he never will improve." That, evidently, is the modern trend—if you can't read you will have to get along without it. During The Stroller's years along the journalistic trail, the most notable case of a fellow making a success of himself without being able to read was Joe Louis, the former heavy-weight champion who came out of Detroit's "Paradise Valley" to earn raving as one of the greatest heavy-weight champions of all time. The Stroller never will forget the afternoon he saw Joe for the first time and learned, in a peculiar way, that he could neither read nor write. At the time, The Stroller was toiling in the sports department of the Detroit Free Press and was accepting en-

tries for the Golden Gloves Tournament being sponsored by the paper. This afternoon, as he looked up from his desk, he noticed this strapping young fellow standing in the doorway. "IS THIS WHERE YOU enter the gloves?" he asked. He was told this was the place and The Stroller handed him an entry blank to fill out. "Will you fill it for me?" he asked. So the questions were asked and duly recorded on the blank. This done, Joe was asked to sign it. "Will you sign it for me?" he asked. Then it dawned on The Stroller that this young man could neither read nor write, for when he signed the entry, "Joe Lewis," Joe never mentioned that his name had been misspelled. It wasn't until a few months later that Joe's sister sought out The Stroller and asked, "When are you going to spell my brother's name right—it's Louis and not Lewis." And so his name went into the record books as Joe Louis and he carried it to fame.

## It's your theater

"The smell of the greasepaint, the roar of the crowd." Since before Shakespeare penned a word of prose or poetry, humanity has been lured to the stage, seeking the thrill that only the theater can offer. For the uninitiated, the spectator in the crowd, the life of a thespian seems glamorous, yet unreachably. But there is another side to the craft to which too few pay attention, even though it is very close to home. For those of us who have been captured by the age-old crafts' magic, yet have other fulltime vocations, community theater is dear to the heart. COMMUNITY THEATER EXISTS just about everywhere. In Michigan, alone, there are nearly 100 groups registered with the Community Theater Association of Michigan. While some have reached respectable heights, most are small, struggling enterprises, sustained by a dedicated few. In western Wayne County there are the Livonia-Redford, Plymouth and Wayne-Westland community theaters. Unfortunately for those who labor behind the scenes, there is often too much greasepaint and very few cheers. Many times the laughs come from the cast and crew, who watch one another blow a line, walk off the wrong side of the stage or trip over a misplaced prop. A friend once said, "It ain't Broadway, but it's all we've got." And therein lays the glory of community theater. The part-time activists become jacks-of-all-trades. The leading man may look the part of the suave and debonair entrepreneur on opening night, but a more discriminating person would notice the slight bags under the eyes. For weeks before, the leading Lothario undoubtedly was painting flats,

sanding and sawing. And so it is with every member of the cast. But don't be fooled into believing community theater is a half-baked attempt at theater. Some pretty fine productions are managed by most groups at one time or another. I FIRST BECAME hooked on the community theater circuit when I was 13 years old. An avid movie watcher from the year one, I knew I had to give it a try. Just once, I said. Nonsense. Nobody gets on a stage just once. If you fail the first time, you have to go back and redeem yourself. On the other hand, if your performance is greeted by those sweet sounding cheers and applause, you're addicted forever. But to be sure, the frustrating and embarrassing moments outnumber all others. I'll never forget my first attempt at a Shakespearean role. It was Petruchio, in "The Taming of the Shrew." Thrilled to win the part, I was nevertheless apprehensive over having to wear a pair of tights. Teenagers do have those hangups. My worst fears came to fruition. I can see it now. Playing opposite a delightful young lass of whom I was enamored, I strutted about the best I could in the unwieldy costume. The curtain opened. The words still ring in my ears. "I pray you do. I will attend her hear and woo her with some spirit when she comes." I pronounced with all the ardor of a Laurence Olivier. With a great dramatic gesture I turned towards the fair maiden who was entering stage left and...rip. Those cursed tights split from stem to stern. Horrors of all horrors had been cast upon me. The girl laughed and the crowd giggled. As for me,

scarlett wasn't deep enough to describe my countenance. THERE WERE other times as wretched. In "The Miracle Worker," a play about Helen Keller and her struggle in learning how to communicate, I was required to sing a few lines. Now singing isn't one of my more developed talents. As a matter of fact a frog sounds better. How well I recall the hoots and hollers from friends as I broke out in my unsorthy rendition of "Buffalo Girl." That play was doomed from the beginning. At the most dramatic juncture, when Annie Sullivan is teaching Helen to say "water," Annie grasps the pump handle to have Helen feel the water. You guessed it. The pump came off in Annie's hand. The incidents are countless. Having to apply makeup in gymnasium kitchens, unintentionally falling downstairs and a slap or two in the face by a temperamental actress are vivid memories. But believe me, folks, community theater really is fun. Many times you can see just as dramatic a performance by some local folks as you can see by stars. Local governments are becoming more cognizant of the groups and are setting aside money for them. Let's hope the trend continues. Who knows? Someday you may have your turn in the spotlight.

HENRY M. HOGAN, JR., Co-Publisher  
PHILIP H. POWER, Co-Publisher  
JOHN REDDY, Executive Editor  
TIM RICHARD, Editor,  
Wayne County Newspapers  
ARTHUR SHAFER, Marketing Director  
Member of  
MICHIGAN PRESS ASSOCIATION  
SUBURBAN NEWSPAPERS OF AMERICA  
NATIONAL NEWSPAPER ASSOCIATION

**Canton Observer & Eccentric**  
DIVISION OF SUBURBAN COMMUNICATIONS CORPORATION

### A WARM-HEARTED KID ... WITH A CHILLING PROBLEM AT HOME

Things are changing. He used to be outgoing, lovable, happy. His teachers liked him. He had lots of friends. They came home with him, called him, hung around with him all the time. But the drinking problem at home is making him change. He's lonely. His grades are dropping. Kids don't come around anymore. He won't let them. He is ashamed of the alcoholic parent. Embarrassed. Why should the alcohol problem at home be a blight on his life? Who has the courage to call for help? Doesn't anybody care!

Call 525-5630 for help right now

**DIAL-A-MESSAGE 525-3881**  
You can listen to a brief message in privacy by dialing this number. A new message every week.

**Insight INTERNATIONAL, INC.**  
12844 Farmington Road, Livonia  
Located in the Trade Center

### ARE YOU UNEMPLOYED? IS YOUR JOB THREATENED?

You can do something now to insure a better future through

## WAYNE COUNTY COMMUNITY COLLEGE

- One-year certificate and two-year degree programs in 27 career fields
- Lowest tuition around—\$11 per credit hour
- Open enrollment — Anyone 18 or over can enroll without a high school diploma
- Veterans services
- Saturday classes
- Class locations convenient to all residents of Wayne County

**ENROLL FOR SPRING AND SUMMER CLASSES APRIL 28-MAY 2**

at one of these locations near you  
(LATE REGISTRATION MAY 5 - MAY 9)

GLENN HIGH SCHOOL  
36105 Marquette Way, Wayne  
6-9 p.m., April 28—May 1  
Late Registration: May 5-8

MILTON CENTER  
1771 Henry Ruff Rd., Inkster  
12-3 p.m., April 28-May 1  
Later Registration: May 5-8

**CLASSES BEGIN MAY 5**  
Call 832-2300 or 832-5500

**WC CC Wayne County Community College**

4612 Woodward Avenue Detroit, Michigan 48201

TUESDAY NITE STEAK SPREE  
OUR GENUINE \$1.79 RIB-EYE STEAK FOR ONLY \$1.39

# NEW!

## Save even more at Steak & 4!

**IT'S AS EASY AS 1-2-3:**

1. Buy any dinner\* at Steak & 4 this week, and we'll give you a "Bonus Chip"...
2. Next week, buy any dinner\* (except Tuesday night) and redeem your "Bonus Chip" for a FREE beverage...
3. Plus, receive another "Bonus Chip" — good for FREE beverage, next week...

**NOW, MORE THAN EVER, IT PAYS TO EAT DINNER AT...**

**STEAK & 4**  
BEEF BURGERS CHICKEN OFISH FRY

\*After 4:00 pm

25025 Telegraph Rd. at 10 Mile Rd.  
1050 Ann Arbor Rd. — (at Harvey St.) 2 Blocks East of Sheldon Rd.

# Reach for Recovery has program to reach more mastectomees

By MARGARET MILLER

It's to be titled "Mastectomee Update," and Livonians Gerry Dahler and Audrey Penskar want it known that the April 22 program is "strictly upbeat."

Upbeat because Mrs. Dahler and Mrs. Penskar and others in the American Cancer Society's Reach to Recovery program are anxious to share with all women who have undergone breast surgery the latest in helpful products and advice.

"Mastectomee Update" is an educational seminar, complete with displays and a fashion show, scheduled to begin at 1 p.m. Tuesday in the Roostertail club, at the foot of Marquette in east side Detroit.

It is the first such program to be sponsored by the Wayne County Unit of Reach to Recovery, a group within the cancer society that makes supportive visits to women who have undergone mastectomy or are facing the removal of a breast.

IN THE "UPDATE" program there will be greetings from Wayne County Sheriff William Lucas, a message from First Lady Betty Ford, herself a mastectomee, and a panel discussion on the latest in detection and treatment of breast carcinoma, as well as the display and fashion showing of apparel.

Participating in the panel will be Dr. Robert O'Bryan, oncologist at Henry Ford Hospital, Dr. John Wolfe, Hutzel Hospital radiologist and Dr. Angelos Kambouris, surgeon on the staffs of Sinai, Mt. Carmel and Harper Hospitals.

They will talk about new techniques and answer questions the women attending may put to them.

"We have regular programs of this type for our Reach to Recovery volunteers," said Gerry Dahler, who coordinates the program in this area.

"But we feel sure there are a lot more women out there who have un-

dergone the surgery alone and need contacts with others and updated knowledge. This program is for them."

Reach to Recovery, Mrs. Dahler explained, involves visits, always with the permission of the physician involved, by mastectomee volunteers to women who have just undergone the surgery.

These volunteers, having been there themselves, can talk with the patients about the problems with losing a breast, both the physical and the psychological kind. They also can demonstrate helpful exercises, including reaching.

Audrey Penskar, along with Bev McDevitt of Livonia and Bev Landeau of Westland, are Reach for Recovery volunteers who are among the models for the fashion show Tuesday.

They will model various makes of bras and bathing suits that can be worn by mastectomees, and there will be discussion of the advantages of the different kinds of prosthesis, the form used to replace the missing breast, and the garments that cover it.

"WE WANT TO SHOW women you can look great as well as feeling fine and leading a really active life," said Mrs. Penskar, who will be modeling a special bathing suit with tunic and bikini pants.

Another bathing suit, Mrs. Dahler mentioned, will be modeled by a 67-year-old mastectomee, Mrs. McDevitt will show a dressy pantsuit with the necessary high neckline and sleeves.

Most of the styles shown will be assorted bras, the volunteer models said, because there are so many new kinds of bras and prostheses.

One to be brought to the show is made by Jodee and utilizes a new kind of medical gel.

The prostheses are expensive, ranging upwards from \$60, the women said, so it's important to know what is available.

MRS. DAHLER also mentioned that



REACH TO RECOVERY volunteers Dolores Landeau (left), Audrey Penskar and Bev McDevitt will be models for a mastectomees' fashion show April 22. (Staff photos by Art Emanuel)



GERRY DAHLER

"as soon as this program is finished our next project is going to be to start agitating to have the cost of the forms covered by Blue Cross."

"We feel they are as necessary as glasses and should be treated in the same way from a medical insurance standpoint," she said. "They definitely are a necessity—you get backaches from going without that extra weight."

The four local women all felt they had made it through the mastectomy adjustment with not too much trouble and Mrs. Landeau, who has had both breasts removed, 12 years apart, said she was back on her job with the Wayne County Stabilization Commission two weeks after the second surgery.

"That's sooner than most women," Mrs. Dahler said, "but most of our Reach to Recovery volunteers have made good adjustments that that is why we are so anxious to have them visit women newly facing the program."

## New Schoolcraft courses to deal with jobs, layoffs

Are you getting everything you are entitled to while you are unemployed?

And, when a chance to work again appears, do you know the best way to handle a job interview?

Spring classes, sponsored by Schoolcraft College community services and scheduled to begin the week of April 28 in Garden City School District, will attempt to find answers to questions like these.

"Surviving Layoffs" is the title of a course designed primarily for people who are laid off or unemployed. "Job Crisis Clinic," intended primarily for women, aims to give women confidence so they can successfully seek employment. Both will run four weeks and cost \$5.50.

Three additional classes will also be offered. "Lifestyle Planning for Women," "Protection Against Rape," and a course for couples only titled "Understanding Changing Lifestyles."

THE COURSE on surviving layoffs will be coordinated by Luther Bird, counselor at Livonia Churchill High School, and will be held in Garden City West High, 1851 Raddiffe, starting Thursday, May 1, from 7-9 p.m.

The first session, taught by a representative of the Wayne County Department of Social Services, will consider benefits and social services. Budget management and nutritional information will be presented by a representative of the Wayne County Extension Service in the second session.

Constructive use of time will be taken up by recreational and handicraft consultants and a representative of the Livonia Office of Volunteer Energies at the third session.

The final class will be visited by a representative of the Michigan Employment Security Commission, who will suggest additional income possibilities.

SELF-EVALUATION will be the basis of the first meeting of the job crisis clinic, which will begin Monday, April 28, from 7-9 p.m.

Job search skills will be offered at the second session with interview techniques offered at the third. On-the-job problems, discrimination, your role with the company will be discussed at the final session.

The course, conducted by Amy Wilson Durfee, a placement specialist with the Jewish vocational service, will be held in Garden City East High, 6500 Middle Belt.

"Protection Against Rape," a four-week course, will begin Thursday, May 1, from 7-9 p.m. in West High.

"Lifestyle Planning" will begin in East High Monday, April 28, from 7-9:40 p.m. It is a six-week course, as is "Understanding Changing Lifestyles," which will meet in West High starting Tuesday, April 29, from 7-9:40 p.m.

Tuition for classes that meet six times is \$11. For further information contact the Schoolcraft instructional center in Garden City.

## She's Dorothy Ferrari

# Top secretary to be honored



SECRETARY OF THE YEAR Dorothy Ferrari and her boss, Scans Associates controller Brooks Marshall Jr. (Staff photo)

Dorothy Ferrari of Livonia will be honored by the Town and Country chapter of National Secretaries Association (International) when the chapter holds its Secretaries Week dinner Wednesday, April 23.

The dinner, for bosses, secretaries and guests, will be held in Stouffer's Northland Inn in Southfield beginning at 6:30 p.m.

Mrs. Ferrari, secretary to Brooks Marshall Jr., controller of Scans Associates, Inc., of Livonia, has been a member of the NSA since 1966 and has served as an officer and on a number of committee assignments.

Besides being local secretary of the year, she is a finalist in the competition for top honors in the Michigan NSA Council.

Selection of the secretary of the year is based on education, secretarial experience, NSA service at chapter, division and international levels, and an appearance before three judges to answer questions about happenings in a business office.

The judges, representing management, education and the secretarial field, rate the secretary on her appearance, poise and extemporaneous answers to the questions.

The theme of the 24th annual Secretaries Week, being observed April 20 to 26, is "Secretaries: Minding Everybody's Business Everywhere."

In this regard, Esther P. Vots, Town and Country chapter president, commented that secretaries in their regular business dealings "function in pivotal roles, assisting executives in business, industry, government and the professions."

"In the office work force," she added, "experienced secretaries continue to enjoy a high rating for marketable skills. On the front line of management support staffs, they are the detail planners and doers for carrying out policy. Secretaries mind the employers' business, not as self-appointed busybodies but as executive surrogates."

"A secretary shall be defined as an executive assistant who possesses a mastery of office skills, who demonstrates the ability to assume responsibility without direct supervision, who exercises initiative and judgment and who makes decisions within the scope of assigned authority."

During Secretaries Week, NSA will stress its commitment to support of ratification of the Equal Rights Amendment; to increasing awareness of the Certified Professional Secretary (CPS) rating and to encouraging upcoming generations of secretaries through the Future Secretaries Association program.

## Lamaze classes scheduled in area

The film, "The Story of Eric" will be shown.

Husbands are urged to attend, but it is not necessary. Couples are urged to register as early in pregnancy as possible so as to receive important information on nutrition and physical fitness which is provided in an orientation class.

Classes meet once a week.

On Wednesday, April 23 a Lamaze series will begin at 8 p.m. in St. John

Episcopal Church, 555 S. Wayne, Westland. Another series will start Monday, May 5 at 7 p.m. at Wickes Furniture store, 29635 Seven Mile, Livonia.

Schoolcraft College, 18600 Haggerty, Livonia, will be the location of a series that will begin Saturday, May 10 at 9:30 a.m. Garden City Osteopathic Hospital, 6245 Inkster, will host a series starting Monday, May 19 at 7:30 p.m.

May 19 will also be the day a series starts in Sword of the Spirit Church, 34563 Seven Mile, Livonia. The time is 7:30 p.m.

The sixth series of classes commence Thursday, May 22 in First Presbyterian Church, 701 Church, Plymouth.

For further information contact Mrs. Karen Januszek, 18926 Shady-side, Livonia, or write Box 311, Plymouth.

# Tiger rookie Ruhle has Livonia buzzing

By W.W. EDGAR

LIVONIA— When Vern Ruhle, the Tigers' rookie right-hander who beat the New York Yankees in his first start this season, steps to the mound the eyes and ears of hundreds of Livonians are focused on their radio or TV to listen to or watch every move.

This is especially true in the city offices where his mother-in-law, Mrs. Margaret Mekulen, is secretary to Bob Osborn in the Engineering Department, and in City Hall where his wife, Darlene, is a part-time secretary to Dan Gilmartin in the Industrial Relations division.

Outside of the government offices, the TV sets in many of the commercial establishments have the game on the tube and word flashes around the city that "The kid is pitching."

Ruhle, who lives with his wife at Five Mile and Hubbard, is not the first Livonia resident to hurl for the Tigers, but he is the first to command excitement by his performances.

Years ago young Harry E. Wolfe had a tryout with the Tigers, but never made it to the majors. In later years Billy Hoefft lived in the city and Bob Bruce, whom the Tigers traded

to Houston, still lives here. And Denny McClain once owned a paint company in the industrial park. But Ruhle is the first to capture the imagination of the fans as a rookie hurler.

When he started against the Yankees in Shea Stadium in New York for his maiden effort of the year, the word passed around the city and everywhere one went he heard the same question, "How's the kid doing?"

"If you think the people around the city were interested," his mother-in-law said, "you should have been in our home. We were so interested in television we didn't care much about anything else."

And his young wife added, "I watched every pitch and was so excited."

The young right-hander readily confesses that he was excited, too, when he took the mound in the big city.

"It was the best feeling I ever had in baseball," he said, "just to think that I was starting against the Yankees in New York."

He admitted he was quite confident, knowing that Manager Ralph Houk had faith in him and that Tom Veryzer, a teammate in the minors, was playing shortstop.

"Tom sure came through with sever-

al great plays that helped a lot," the young right hander said.

Now his only hope is that his showing wasn't just a flash and that he can keep his place in the starting rotation.

His showing wasn't too great a surprise to the Tigers, for Vern was a 20 game winner last season. He won five games at Montgomery, Ala., 13 at Evansville, and two in Tiger stadium before the season closed.

"Vern has dreamed of being a major leaguer ever since he was six years old," his mother-in-law said, "and his parents approved his playing provided he had good marks in school. He made the grade in high school and graduated from Olivet College where he met his wife, Darlene, a graduate of Livonia Stevenson high school."

Darlene, too, is excited by the twist of events that placed her with the major league wives. Her eyes sparkled when she recalled the grand times she had with Mrs. Bill Freehan and Mrs. Al Kaline, during the training camp days in Lakeland.

And now, along with that excitement, she is jubilant about another adventure. She expects her first child in September and hopes it will grow up to be a major leaguer, too.



DETROIT TIGER ROOKIE pitcher Verne Ruhle is a solid Livonian. The righthander not only makes his home in Livonia, but his moth-

er-in-law, Mrs. Margaret Mekulen (left), and his wife (center) both work for the city. (Staff photo by Art Emmanuel)

# East wins first league track meet in five years

Garden City East won its first Northwest Suburban League track meet in five years to highlight area track action last week.

The Panthers came on strong in distance races and field events to top Oak Park Thursday, 79-44.

In other action, Livonia Churchill topped Waterford Mott, Livonia Franklin kept its record perfect by beating North Farmington, Livonia Bentley lost to Bishop Borgess, Thurston topped Farmington Harrison and Plymouth Canton was clobbered by Northville.

Brian Sweaze took the 880 yard run for East in 2:05.1 and Art Kitz turned in a 4:34.4 mile to win that event by more than 30 seconds in the Panther victory.

East swept the shot put and took firsts in the high jump and pole vault in the victory. In all, the Panthers took firsts in 11 of the 15 events to give first-year coach Brian Murphy his first victory at East.

### CHURCHILL—MOTT

Bill Reardon had a heave of 54-11 in the shot put to highlight Churchill's 68-55 Western Six victory over Waterford Mott.

Brian Hanna and Jim Packard combined for the Chargers to dominate the hurdle events.

Hanna took a first in highs at 15.9 and Packard was four-tenths of a second behind him. It was Packard's turn in the lows as he covered the 180 yards in 21.0 with Hanna taking second, an identical .4 seconds behind.

Larry Janowski's 20 foot effort in the long jump was more than a foot better than the nearest competition.

### FRANKLIN — N. FARMINGTON

Dan Quinn took two firsts and a second to lead Franklin to a 67-56 Northwest Suburban track victory over North Farmington Thursday.

Quinn took both sprint events, winning the 100 yard dash in 10.4 and taking the 220 yard event in 23.6.

In addition, Quinn finished second in the long jump with a jump of 18-11.5.

North Farmington took firsts in eight of 15 events, but the Patriot depth won out.

Franklin is now 2-0 on the year while North Farmington is 0-2.

### BORGESS — BENTLEY

Bishop Borgess took firsts in nine of 15 events en route to a 71-52 victory over Livonia Bentley in non-league track action last Monday.

Junior Gary Hicks took firsts in the 440 yard dash (51.3) and high hurdles (15.4) for Borgess.

Steve Jaremski had a 53-10 heave in the shotput for the Spartans to win by nearly 10 feet.

### THURSTON — HARRISON

Darrell Korzym and Matt Whitehead each took two firsts to lead Thurston to a 75-48 track victory over Farmington Harrison last week.

Korzym leaped 6-2 in the high jump and ran the high hurdles in 16.6 to take his firsts. In addition, Korzym took a second in the long jump.

Whitehead, one of the area's quickest sprinters, had a 10:2 clocking in the 100 dash and ran the 220 in 23.4 for his firsts.

Dan Duryea raced the 880 run in 2:06.1.

### CANTON—NORTHVILLE

Northville clobbered Plymouth Canton 81-54.15 in the Western Six track opener for both schools.

Senior Mike Potter took a first in the half mile, a second in the quarter mile and anchored the victorious Chief mile relay team to highlight action for Canton.

Jim Mack, who won state Class B regional honors in the pole vault last year, took his event with a vault of 12 feet.

# Spartans win in 8

Livonia Stevenson scored five runs in the first extra inning then held off a determined Waterford rally to take its Inter Lakes Conference opening game 7-5 Wednesday.

The Spartans held a 2-1 lead going into the bottom of the seventh but Waterford rallied for a run to send the game to extra innings.

Stevenson scored five runs in the top of the eighth but John Kolis had to come on in the bottom of the inning to

deliver a shaky but effective performance in holding Waterford to three runs.

Ray Warring picked up the victory for the Spartans who were paced in the offense department by Randy Besh's two hits.

Batteries — Stevenson: WARRING, Kolis (8) and Pacien. Waterford: BATES and Tippen.

STEVENSON 000 011 05 — 7-10-4  
WATERFORD 010 000 13 — 5-5-1

# Borgess hurdler perfect—wins first league game

According to Bishop Borgess baseball coach Jim Brisky, Mark Gergel is just another pitcher on a good staff of Spartan hurlers.

But last Monday, Gergel rose to perfection in game against Redford St. Mary, striking out seven and not allowing a baserunner as Borgess took its Catholic League AA division opener, 4-0.

The feat was a first in Spartan history. The mere 46 pitches which Gergel used to dispose of the opposition was also a Borgess record.

"I try to mix up my pitches. My curve was working real well for me," said Gergel after the game.

The senior righthander gave ample credit to the Spartan defense which played errorless ball behind him.

"I only struck out seven. That means that our fielders handled 14 chances. It was a team effort," he said.

Only two balls left the infield, both routine flyballs.

Gergel admitted that he was "pretty nervous" in the final inning but his curve kept breaking and he got the final St. Mary batter via a strikeout.

Borgess got its offense started with Ken Kanasiak's two-out triple in the second. Kanasiak scored on Gary Mulka's base hit.

In the third Jim Pearce walked and moved to third on Greg Heimbuch's single. Pearce scored on John Wedesky's ground ball which forced Heimbuch at second.

The Spartans added two runs in the

sixth when St. Mary pitcher Paul Duke forced in two runs by walking Tom Quay and hitting Pearce with the bases loaded.

Batteries: Bishop Borgess — GERGEL and Heimbuch. St. Mary — DUKE and Hool.

BORGESS — 011 002 0 — 4-5-0  
ST. MARY — 000 000 00 — 0-0-0

# C'ville wins pair

Clarenceville High School won a pair of games last week to up its baseball record to 2-1 and begin its run for Wayne-Oakland League honors.

The Trojans clobbered Milford 10-0 with Tony Phillips going the distance and holding Milford to one hit.

Phillips, who displayed an overpowering fastball, tired in the seventh and walked the bases full before pitching out of the jam.

The lone Milford hit came in the second inning. The Milford batter hit a hard shot back to the box which Phillips deflected.

The ball rolled into centerfield, taking Phillips' glove with it to spoil the no-hitter.

Chris Curtis went three-for-five and Rick Beyer had four RBIs for the Trojans.

In Clarenceville's opening Wayne-Oakland League game, the Trojans stopped Bloomfield Hills Andover, 1-0.

Tony Phillips opened the third inning for the Trojans with a base hit and was sacrificed to second. Tim Laird walked and Phillips was erased by a fielder's choice.

Laird then scored when an attempted pick-off play went into the outfield for the game's only run.

Chris Curtis picked up the win for the Trojans, stopping Andover on four hits.

Batteries: Clarenceville: PHILLIPS and Beyer. Milford: TADRA, Laws (4) and Miller.

# No-hitter wins for St. Agatha

ST. Agatha pitcher Greg Sipus made his first start ever for Redford St. Agatha an impressive one as he no-hit Orchard Lake St. Mary as the Aggies opened their Catholic League Second Division baseball season by clobbering the Eaglets 18-0.

Sipus, a junior control pitcher was "mostly picking corners low" according to Agatha coach Jim Brisky.

Third baseman Ron Jess made a spectacular play on the final out of the game, going to his left to scoop up a one-hopper to save the no-hitter.

Sipus helped his own cause by getting three hits and five RBIs. Ron Monette was on base three times and had three RBIs. Dave Mully drove in four runs and had a bases loaded triple in the first.

Batteries — St. Agatha: SIPHUS and Beyrand. St. Mary: McCLUSKEY and Koudrat.  
ST. AGATHA 805 050 0 — 18-12-2  
ST. MARY 000 000 0 — 0-0-3

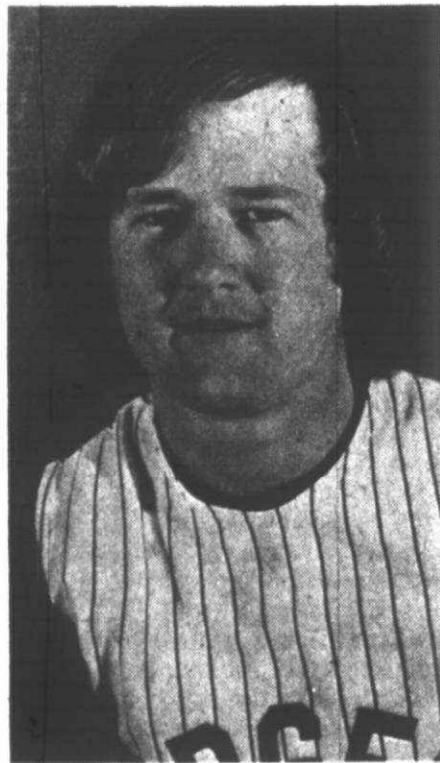

MARK GERGEL

# Chief pitcher gets no-hitter

Plymouth Canton got a no-hit performance out of 16-year-old Bill Parson and opened its Western Six baseball season with a convincing 5-0 victory over Northville Wednesday.

The junior righthander recorded 14 strikeouts and allowed only two balls to be hit out of the infield. Parson walked one and hit one batter and Canton committed two errors.

Mike Verduce picked up two RBIs and went three for four to pace the Canton attack. Brian Sternberger continued his amazing hitting with a single, a double and two RBIs.

Batteries — Canton: PARSON and Close. Northville: BURGER and White.  
CANTON 112 010 0 — 5-0-2  
N'VILLE 000 000 0 — 0-0-2

Before you buy any pool

# come and see

the beautiful one!

## it's built to last!

**MARK III**  
patented design - built exclusively by Fanta-Sea

Grade A California Redwood - lifetime guarantee plus beauty, year after year

Gussets - Unique, closed design makes pool inaccessible to small children

Water Walls - 3/4" Acrylic Finish, 50% Stronger than any other Pool Wall

18" Steel Bar Joists - One ton of Steel. Unmatchable Strength & Safety

Heavy Duty Liner - 20-gauge Quality Control Liner, Guaranteed 20 years

**IMMEDIATE DELIVERY on the strongest, longest lasting pool you can buy!**

Come out today and let us prove why the Mark III is the best investment you can make in any kind of swimming pool. See the full size beautiful one on display.

It's designed, engineered and manufactured only by Fanta-Sea. Constructed from beautiful Grade A California Redwood... built around a ton of steel... built to last and last and last.

Fanta-Sea has a pool size to fit every backyard and financing plans to fit every budget. Order your pool today... don't miss a single day of the upcoming swimming season.

See our complete line of aluminum pools

Own a recreational vehicle or Boat? Ask about our trade-in plan.

**Pools Start at \$1,995**

**FANTA-SEA Swim Centers**

23660 Grand River (Near Telegraph)  
Detroit, Mich. 48219

OPEN TODAY!  
HOURS:  
Mon.-Fri. 9 AM-9 PM  
Sat.-Sun. 9 AM-6 PM

**DON'T WAIT! VISIT OUR SHOWROOM TODAY**

CALL COLLECT (313) 255-4510  
DAY OR NIGHT  
For a Free Color Brochure-Call or Write:  
Fanta-Sea Swim Centers 23660 Grand River  
Detroit, MI 48219

Name \_\_\_\_\_  
Address \_\_\_\_\_  
City \_\_\_\_\_ State \_\_\_\_\_  
Phone \_\_\_\_\_

# Panther track girls win two, stay perfect

The Redford Union girls track team won a pair of meets last week to up its season record to 4-0.

The Panther girls clobbered North Farmington 97-8 and nipped Churchill 61-44 to keep their record perfect.

The North Farmington meet was strictly no contest. RU won every event and held North to one second in individual running events.

Linda Kosovac took two firsts and anchored the winning mile relay team. One of Kosovac's firsts, a 16-2 leap in the long jump, set a Panther school record.

Another Redford Union school record fell in the meet against Churchill when RU's Diane Lozon and the Chargers' Joyce Petryl went at it in the two mile event.

After a neck and neck chase all the way, Lozon pulled out a 1.7 second victory in the showdown, setting the record in a 13:23.2 clocking.

Results:

Senior sisters Barb and Jackie Crocie each took a first and each ran on the victorious mile relay team for Salem.

Runi Holder was an easy winner for Salem in the two mile run.

Salem will face Bentley next Wednesday.

Results:

## FRANKLIN—N. FARMINGTON

The Livonia Franklin girls track team opened its Northwest Suburban season last week by dumping North Farmington 70-35.

Patti Brzys took two firsts for the Patriots and anchored the winning mile relay.

Franklin won both dashes with Carol Gerrity taking the 100 yard event in 12.4 and Lori Reamer winning the 220 in 29.7.

Results:

## G.C. EAST—OAK PARK

The Garden City East girls track team opened its Northwest Suburban season Thursday with a 57-47 victory over Oak Park.

Ruth Barrett took a first in the mile run and anchored the mile relay. Theresa Yellick won the 880 yard run and led off the mile relay.

Gwen Wright won the hurdles and the 220 yard dash and finished second in the 100 dash.

East is now 2-1.

## Thurston comeback beats Glenn, 3-2

Thurston High School got a complete job from junior righthander

Randy Rodriguez Wednesday and took its Northwest Suburban League baseball opener from Westland-John Glenn, 3-2.

Rodriguez not only pitched the entire seven innings with outgiving up an earned run, but had a triple and a base hit to help his own cause.

Rodriguez, a transfer student from Detroit Catholic Central, struck out eight and walked just one as Thurston evened its record at 2-2.

Murray Duncan, who pitched a no-hitter in his last appearance, suffered the loss for the Rockets.

Batteries — Thurston: RODRIGUEZ and Beebe. Glenn: DUNCAN and Hicks.

200 000 0 — 2-5-2  
001 002 x — 3-8-3

### Mott tops Chargers

Defending state Class A baseball champion Livonia Churchill dropped its opening Western Six Conference game to Waterford Mott in nine innings, 3-2.

Charger pitcher Warren Wallis took the loss for Churchill. Wallis struck out 14 but his inconsistency cost the Chargers the game.

Leading 2-1 in the bottom of the seventh, Wallis threw two consecutive wild pitches to allow Mott to tie things. Dennis Slater's fourth inning triple to right-center field was the big offensive blow for the Chargers.

Batteries — Churchill: WALLIS and Nelson. Mott: STRADER and Stepanski.

CHURCHILL 000 200 000 — 2-3-2  
MOTT 100 000 001 — 3-6-1

### East diamondmen clobber OP, 15-2

Garden City East scored seven runs in the top of the first inning and went on to take an easy 15-2 victory over Oak Park in opening baseball action in the Suburban Eight League.

The Panthers had six hits and two walks in the opening inning to put the game away early. Britt Ponte picked up three runs batted in for the day.

Greg Emery was credited with the win for East, now 4-0 on the year. Emery allowed only three hits and only one earned run as he struck out 14 while walking seven.

Batteries — East: EMERY and Ponte. Oak Park: BAKER and Said.

EAST 724 002 0 — 15-13-1  
OAK PARK 100 000 1 — 2-3-4

### Anders delayed

The opening round of the 11th annual Les Anders baseball tournament was postponed for one week Saturday morning when tournament officials found area fields unplayable. Times and schedules will be announced later.

**GARAGE DOOR OPERATORS**  
FOR ANY DOOR  
GENIE "450"  
\$180 Installed  
1 Year Warranty  
Any Suburb  
**ALLIANCE**  
AUTOMATIC DOOR CO.  
531-0890  
SOUTHFIELD

**SYSTEMATIC BOOKKEEPING L & J ACCOUNTING**  
Merging For Better Service  
• Complete Bookkeeping & Accounting • Pick-up & Delivery  
Garden City 563-2222 Troy 689-9110 After 6 p.m.

**DISCOUNT TIRE PRICES**  
ONE PRICE ANY SIZE CLEARANCE TIRE IN STOCK  
**\$19.95** PLUS FED TAX 1.77-3.51  
RADIALS-BELTED-4 PLY-78-70-60 SERIES  
**BEAT THIS!!** \$6.66 MOST CARS  
**ALIGNMENT**  
HEADQUARTERS FOR  
• ALIGNMENT  
• MUFFLERS  
• BRAKES  
WE ARE HERE  
**PLYMOUTH TIRE & AUTO SERVICE CENTER**  
705 W. Ann Arbor Rd. At Main St. Plymouth • 453-3165

**BRAKE SALE!**  
30,000 Mile Guarantee  
**DELUXE DRUM BRAKES** 49.99  
**DELUXE DISC BRAKES** 59.99  
**TUNE UPS!!** 10,000 Mile Guarantee  
8 cyl. 29.99  
6 cyl. 27.99  
4 cyl. 25.99  
**HEAVY DUTY SHOCKS** 6.99 per shock  
**AIR SHOCKS** 39.99 per pair  
INSTALLATION AVAILABLE  
Balance 7.99  
Lubrication 10.99  
Alignment 11.99  
Battery 23.99  
**60 & 70 SERIES**  
**4 Ply Polyester**  
Factory Firsts  
Size PRICE P.E.T.  
D78-14 whitewall 15.99 1.83  
D78-14 whitewall 18.99 2.15  
E78-14 whitewall 19.99 2.24  
F78-14 whitewall 22.99 2.41  
G78-14 whitewall 23.99 2.55  
H78-14 whitewall 24.99 2.77  
500-15 whitewall 19.99 1.78  
G78-15 whitewall 23.99 2.63  
H78-15 whitewall 24.99 2.82  
L78-15 whitewall 27.99 3.13  
**Super Savings Center**  
29805 GRAND RIVER AVE FARMINGTON HILLS  
474-1766  
WE ACCEPT MAJOR CREDIT CARDS  
CONVENIENCE HOURS: 8 a.m. to 9 p.m. Daily  
Closed 8 a.m. to 11 p.m.

**VISIT These Wayne County Dealers Soon!**

**NORTHVILLE**  
DON'S STANDARD SERVICE  
302 Main St. at Church 349-1133

**PLYMOUTH**  
CAL COMPEAU STANDARD SERVICE  
789 Ann Arbor Trail 453-9733  
OLD VILLAGE STANDARD SERVICE  
499 Main St. 453-0040  
SAM & SON STANDARD SERVICE  
1229 Ann Arbor Rd. 455-7777

**REDFORD TWP.**  
JOHN KNACK'S STANDARD SERVICE  
27333 Plymouth Rd. at Inkster Rd. 937-0017  
ANTHONY'S STANDARD SERVICE  
26212 Grand River at Kinloelt 534-5440  
BOTSFORD STANDARD SERVICE  
27901 Grand River at 8 Mile Rd. 476-9877

**GARDEN CITY**  
AL & GEORGE STANDARD SERVICE  
6135 Middlebelt Rd. 421-9682  
MOE'S STANDARD SERVICE  
30259 Ford Rd. at Henry Ruff 421-9674 or 425-0980

**LIVONIA**  
BAIGRIE'S STANDARD SERVICE  
32850 Plymouth Rd. 427-1420  
BELL CREEK STANDARD SERVICE  
27430 Five Mile & Inkster Rd. 522-4790  
BINGHAM'S AUTO SERVICE CENTER  
36375 Five Mile & Levan Rd. 261-3730  
DAN "D" STANDARD SERVICE  
27410 Joy Rd. & Inkster Rd. 522-4995  
DON WILLIS STANDARD SERVICE  
29225 Five Mile & Middlebelt 261-0330  
D—J—STANDARD SERVICE  
34901 Ann Arbor Trail 425-6640  
TWIN ARBOR'S STANDARD SERVICE  
37950 Ann Arbor Rd. at Ann Arbor Trail 464-9030  
ART'S STANDARD SERVICE  
6 Mile & Farmington Rds. 422-1184

**WESTLAND**  
JOY-MERRIMAN STANDARD SERVICE  
31411 Joy Rd. 427-2830  
MID-TRAIL STANDARD SERVICE  
8008 Middlebelt & Ann Arbor Trail 261-3340  
WESTLAND STANDARD SERVICE  
6690 Newburg & Warren 326-0877  
CHERRYHILL-VENOY STANDARD SERVICE  
32785 Cherryhill Rd. 728-0030  
GRAYSON'S STANDARD SERVICE  
1686 Newburg Rd. 721-9559

**STANDARD TIRE SALE**  
Ring our Bell

**4-PLY POLYESTER ATLAS CUSHIONAIRE BIAS PLY WHITEWALL TIRE**

Four polyester cord plies provide strength, comfort, long tire life  
Good traction and wet skid control  
Concave molded for more tread contact with the road

GOOD QUALITY—MODERATE PRICE **\$23.95** Each  
Tire size C78-13 Plus \$1.98 Federal Excise Tax each

**ATLAS RADIAL XL** 2 fiberglass belts, 2 polyester belts  
**ATLAS STEEL RADIAL 70** 7 plies under the tread

Radial construction for control, mileage and greater safety  
Can be your least expensive tires on the long run  
Stay flat on roads even in skids  
Wear better on all surfaces under all conditions

OUR POPULAR PRICED RADIAL **\$36.95** Each  
Tire size CR78-13 Plus \$2.28 F.E.T. each

**ALL-PURPOSE CLUB BAG FREE** when you buy 4 Atlas Radial XL's or Steel Radial 70's plus free Registered Key Protection Plan

OUR FINEST TIRE **\$54.95** Each  
Tire size FR70-14 Plus \$3.01 F.E.T. each

**REGISTERED KEY PROTECTION PLAN FREE** when you buy any four Atlas or Amoco tires

LIBERTY BELL DESIGN • AMOCO EXCLUSIVE  
Individually numbered and registered to your name. If you lose your keys, finder drops in mail, prepaid. Amoco Headquarters has your name and returns keys to you free of charge.  
The number system protects your home.

**6 PLYES UNDER THE TREAD FIBERGLASS BELTED ATLAS FORTY-TWO WHITEWALLS**

More potential mileage than unbelted tire  
Wide low profile  
Smooth ride characteristics  
Proven year after year

PERSONALIZED DOOR KNOCKER FREE when you buy 4 Atlas 42 or Steelborn tires plus free Registered Key Protection Plan

OUR MOST POPULAR TIRE **\$27.95** Each  
Tire size A78-13 Plus \$1.76 F.E.T. each

**COUPON SNOW-TIRE TAKE-OFF SPECIAL**  
We inspect your regular tires before mounting. **ONLY \$3.00** (Mag. wheels extra)  
Coupon expires 4-30-75

**COUPON \$1.00 OFF on ATLAS AIR FILTER**  
A dirty, clogged filter could cost you money!  
Coupon expires 6-30-75

**Super Special!**  
Identify your participating Dealer by this sign  
CHARGE IT with your Standard Oil, Torch Club or Diners Club credit card

# Kmart

SALE PRICES GOOD NOW THRU SATURDAY  
OPEN DAILY 10-10; SUNDAY 11-6

## HERE'S PROOF YOU SAVE MORE DOORBUSTERS



**WOMEN'S NYLON SCARVES**  
Reg. 38\*

Thru Sat. Limit 4

**4 for \$1**



LADIES WEAR  
FASHION ACCESSORY DEPARTMENT

**GIRLS' SWIMSUITS**

Special Purchase Thru Sat.

**\$2**

Girls' swimsuits in a variety of colors and styles for this once-only sale!

Limit 2



**MEN'S WORK SOCKS**  
Reg. 1.11

Thru Sat. Limit 4

**88¢**



**LITTLE GIRLS' PANTIES**  
Reg. 58\*

Thru Sat. Limit 6

**3 for \$1**



**MEN'S SHORT SLEEVE KNIT PLACKET SHIRT**  
Reg. 5.88 Thru Sat.

**2<sup>96</sup>**

Men's placket with pocket. 100% polyester. Assorted solids with contrast trim. Charge It!

NOT EXACTLY AS PICTURED

Limit 3



**DECORATOR WALL MIRRORS**  
Reg. 3.88

Thru Sat.

**\$2 ea.**

Limit 2



8 OZ.\* CAN  
**VO 5 HAIR SPRAY**

Sale Price Thru Sat.

**66¢**

Limit 2

\*Net Wt.



**WESTCLOX DIGITAL ALARM CLOCK**  
Reg. 15.47 Thru Sat.

Westclox digital alarm clock with drowse feature. Charge It!

Limit 1

**10<sup>47</sup>**



**POCKET CAMERA FLASH**  
FITS MOST POCKET CAMERAS

Sale Price Thru Sat.

**9<sup>88</sup>**

Limit 1



**PINE SOL LIQUID CLEANER**  
Reg. 97\* Thru Sat.

**53¢**

Limit 2



**33 PIECE SOCKET SET**  
Reg. 23.88 Thru Sat.

**9<sup>77</sup>**

Limit 1



**INFANTS' PRINT OVERALLS**  
Reg. 2.66 Thru Sat.

**1<sup>66</sup>**

Limit 2

AVAILABLE ONLY AT THE FOLLOWING K MART STORES

- FORD ROAD NEAR MIDDLEBELT
- WAYNE ROAD AT CHERRY HILL
- PLYMOUTH RD. NEAR MIDDLEBELT
- 7 MILE RD. AT FARMINGTON RD.
- ANN ARBOR RD. NEAR HAGGERTY RD.
- FORD ROAD AT SHELDON ROAD
- GRAND RIVER AVE. AT HALSTEAD RD.

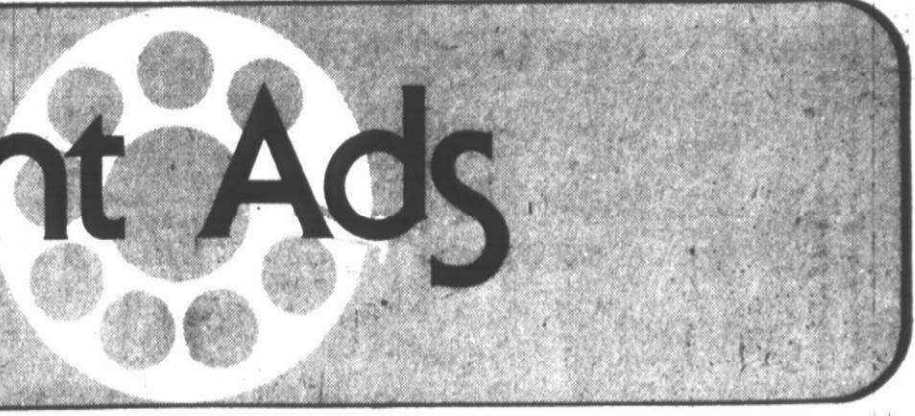

Monday, April 21, 1975

## CLASSIFICATION INDEX

- AUTOMOTIVE**  
 850 Autos for Sale  
 857 Antique Cars  
 854 American Motors  
 856 Buick  
 858 Cadillac  
 860 Chevrolet  
 862 Chrysler  
 864 Dodge  
 866 Ford  
 870 Jeep  
 874 Lincoln  
 876 Oldsmobile  
 878 Plymouth  
 880 Pontiac  
 824 Sports & Imported Cars  
 882 Thunderbird  
 814 Volkswagens  
 816 Auto Parts & Service  
 818 Auto Rentals & Leasing  
 820 Autos Wanted  
 822 Trucks for Sale  
 810 Insurance, Motor
- RECREATIONAL VEHICLES**  
 800 Recreational Vehicles  
 802 Snowmobiles  
 804 Airplanes  
 806 Boats & Motors  
 808 Vehicle & Boat Storage  
 812 Motorcycles  
 Go Karts  
 Mini Bikes  
 814 Campers & Motorhomes
- EMPLOYMENT, INSTRUCTION**  
 518 Education-Instruction  
 500 Help Wanted  
 510 Help Wanted Couples  
 502 Help Wanted Dental-Medical  
 507 Help Wanted - Part Time  
 508 Help Wanted Domestic  
 504 Help Wanted Office-Clerical  
 506 Help Wanted Sales  
 520 Secretarial-Business Services  
 512 Situations Wanted Female  
 514 Situations Wanted Male & Female  
 516 Situations Wanted Male & Female
- MERCHANDISE FOR SALE**  
 702 Antiques  
 706 Appliances  
 700 Auction Sales  
 712 Bicycles for Sale  
 717 Building Materials
- 714 Business & Office Equipment**  
 724 Camera Supplies  
 720 Farm Produce  
 722 Hobbies, Coins & Stamps  
 744 Horses, Livestock & Equipment  
 708 Household Goods—Oakland County  
 709 Household Goods—Wayne County  
 738 Household Pets  
 716 Lawn/Garden & Farm Equipment  
 710 Misc. for Sale—Oakland County  
 711 Misc. for Sale—Wayne County  
 726 Musical Instruments  
 740 Pet Service  
 704 Rummage Sales  
 730 Sporting Goods  
 728 Stereo, Hi-Fi & Tape  
 734 Trade or Sell  
 736 Wanted Misc.  
 732 Wearing Apparel
- NOTICES & SERVICES**  
 604 Announcements & Notices  
 626 Bingo  
 610 Cards of Thanks  
 618 Child Care  
 614 Death Notices  
 628 Entertainment  
 616 Hall for Rent  
 612 In Memoriam  
 622 Income Tax & Insurance  
 606 Legal Notices  
 602 Lost & Found  
 600 Personals  
 624 Professional Services  
 608 Transportation
- REAL ESTATE FOR RENT**  
 400 Apartments to Rent  
 422 Commercial—Industrial to Rent  
 426 Condo/condos—Nursing Homes  
 408 Duplexes to Rent  
 410 Flats to Rent  
 414 Florida Rentals  
 402 Furnished Apartments to Rent  
 406 Furnished Houses to Rent  
 428 Garages to Rent
- 404 Houses to Rent**  
 432 Living Quarters to Share  
 418 Mobile Homes to Rent  
 424 Office—Business Space to Rent  
 420 Rooms to Rent  
 412 Townhouses—Condominiums to Rent  
 416 Vacation Rentals  
 430 Wanted to Rent  
 434 Wanted to Rent Resort Property
- REAL ESTATE FOR SALE**  
 302 Birmingham-Bloomfield  
 304 Farmington-West Bloomfield  
 309 Northville-Nov  
 308 Rochester-Troy  
 306 Southfield-Lathrup  
 311 Homes for Sale—Oakland County  
 312 Livonia  
 314 Plymouth  
 318 Redford  
 316 Westland-Garden City  
 319 Homes for Sale—Wayne County  
 320 Other Suburban Homes for Sale
- 330 Apts. for Sale**  
 360 Business Opportunities  
 348 Cemetery Lots  
 352 Commercial/Industrial  
 322 Condominiums for Sale  
 324 Co-ops for Sale  
 344 Country Homes  
 326 Duplexes for Sale  
 350 Farms for Sale  
 336 Florida Property for Sale  
 354 Income Property for Sale  
 356 Investment Property for Sale  
 340 Lake & Resort Property for Sale  
 342 Lakefront Homes for Sale  
 364 Listings Wanted  
 338 Lots & Acreage for Sale  
 332 Mobile Homes for Sale  
 358 Mortgages—Land Contracts  
 346 Northern Property  
 334 Out of Town Property  
 368 Real Estate to Exchange  
 362 Real Estate Wanted to Rent  
 328 Townhouses for Sale

We reserve the right to classify, revise or reject any want ad. Want ads may be placed until 4 p.m. Tuesday for the Thursday edition and 4 p.m. Friday for the Monday edition. No cancellations accepted after noon Tuesday for Thursday editions or noon Friday for Monday editions. No cancellations before first insertion. No cancellations on ads after the first incorrect insertion. Report any errors immediately. Phone Room hours are 8:30 a.m. to 5:30 p.m. Monday through Friday.

**CALL CLASSIFIED DIRECT**  
**644-1070 OAKLAND COUNTY**  
**852-3222 ROCHESTER AVON TWP.**  
**522-0900 WAYNE COUNTY**

**312 Livonia**  
**WOLFE**  
 IMMEDIATE OCCUPANCY. Immediate occupancy, owner transferred. Ever so nice and priced so cheap at \$37,900. This adorable brick ranch is carpeted throughout, has a full tiled basement and attached two car garage, beautiful landscaping. Features a large country kitchen with built ins, three bedrooms, 1 1/2 baths, located for all family conveniences.  
 HARRY S.

**312 Livonia**  
**WOLFE**  
 COUNTRY LIVING. A tree lined street with 1/2 acre site provides a beautiful country setting for this like new brick and aluminum ranch with large full basement. You will love this large family kitchen with door/wall to patio, three bedrooms, 1 1/2 baths and with an oversized two car garage. Excellent assumption. \$37,500.  
 HARRY S.

**312 Livonia**  
**WOLFE**  
 COUNTRY LIVING. A tree lined street with 1/2 acre site provides a beautiful country setting for this like new brick and aluminum ranch with large full basement. You will love this large family kitchen with door/wall to patio, three bedrooms, 1 1/2 baths and with an oversized two car garage. Excellent assumption. \$37,500.  
 HARRY S.

**312 Livonia**  
**WOLFE**  
 RARE FIND. Truly an immaculate home. Terrific assumption. All large rooms, carpeting throughout, nice lot with trees. \$22,500.  
 HARRY S.

**312 Livonia**  
**WOLFE**  
 WHAT A BUY. All brick colonial with 3 huge bedrooms, one full bath and two half baths. 20 foot modern kitchen, charming family room with fireplace, full finished basement and two car attached garage. \$40,900.  
 HARRY S.

**312 Livonia**  
**WOLFE**  
 OPEN SUN 10 AM to 6 PM. 32910 W. Chicago, 3 blocks east of Farmington. 3 bedroom brick fireplace, finished basement, 2 1/2 car garage. \$35,900. By owner.  
 427-8558

**312 Livonia**  
**WOLFE**  
 COUNTRY LIVING on this 1 1/2 ACRE with 3 bedroom brick bungalow. ALL NEW kitchen with beam ceiling, finished basement, attached 2 car garage. Call Bel Men's Fran.  
 522-3010

**ROBERT BAKE REALTOR**  
 1005 ANN ARBOR TRAIL, Plymouth, Michigan. 453-8200

**NEW ON THE MARKET!** Popular "Woodbrook" in Plymouth is the appealing location of this sizable two story home offering 4 bedrooms, 2 1/2 baths, formal dining room, family room with fireplace, first floor laundry, finished and carpeted basement, and 2 1/2 car attached garage. There is a quiet, isolated study too. Central air plus many other wonderful extras. \$73,900. Call 453-8200.

**FIRST OFFERING!** An extraordinary setting on over an acre. Pleasantly small but reflecting generous room sizes and an interesting floor plan. 2 bedrooms, 2 fireplaces (living and carpeted lower level), 24 x 15 living room, full basement, and attached two car garage. Central Air! Among very fine homes in a quiet restful neighborhood! \$50,900. Call 453-8200.

**HERE'S AN OUTSTANDING PLYMOUTH HOME** off N. Territorial that is perfectly ideal for those desiring a large home combined with good quality at a fair price. 6 bedrooms, 3 1/2 baths, gracious slate entry, 27 x 15 family room with fireplace, formal dining room, first floor laundry, full basement, and oversized side entrance 2 1/2 car garage. Its interior condition is very good. \$89,900. Call 453-8200.

**A HOME THAT HAS EVERYTHING!** This inviting two story home has all the desired features: 4 bedrooms, 2 1/2 baths, a study, family room with fireplace, formal dining room, 1st level laundry, basement, and oversized end entrance garage. A gracious entry hall and an impressive master bedroom suite are characteristics of a one-of-a-kind custom home. You'll find its location and fine condition to be everything you have looked for. \$89,900. Call 453-8200.

**312 Livonia**  
**WOLFE**  
 THREE bedroom brick ranch, 1 1/2 baths, family room, country kitchen, excellent condition. Must sell. Make offer. 15566 Noia Circle.  
 464-3822

**312 Livonia**  
**WOLFE**  
 LIVONIA TRI-LEVEL. 1st TIME OFFERED. BIG ROOMS. In this spacious brick and aluminum tri-level 3 bedrooms, office, 1 1/2 baths, 26' terrace, new kitchen, 18' dining area. Some of the extras include built-in air conditioner. GREEN HOUSE on 2 car garage, gas bar-b-que, semi-sunken pool and more. HURRY!  
 Red Carpet REALTORS 522-3500

**312 Livonia**  
**WOLFE**  
 OVER 1/2 ACRE. Attractive snow white aluminum bungalow on nearly 1/2 acre countryside site, and you'd believe - with a full basement and two car garage. An older home but so nicely kept. Tastefully carpeted, spacious living room, kitchen appliances, excellent assumption. \$27,990.  
 HARRY S.

**312 Livonia**  
**WOLFE**  
 LIVONIA TRI-LEVEL. Face brick family home with 3 large bedrooms, 1 1/2 baths, deluxe recreation room PLUS family room. Carpet throughout 2 car garage. For extras, call.  
 Red Carpet REALTORS 522-3500

**312 Livonia**  
**WOLFE**  
 LIVONIA 3/4 ACRE. Brick and aluminum older home in excellent condition, situated on 1/2 acre with stream, 3 large bedrooms, full bath up, first floor lav and large modern kitchen, dining room, full basement and 2 car garage. \$39,900. Call.  
 Red Carpet REALTORS 522-3500

**312 Livonia**  
**WOLFE**  
 LIVONIA SCHOOLS. Super Clean. OWNER TRANSFERRED. NEW LISTING. All brick ranch, 3 bedrooms, carpeting throughout. Beautiful large kitchen, full basement. New 2 1/2 car brick front garage. \$28,900. \$2,900 down or assume 6 3/4% GI mortgage. Call 261-1010.

**312 Livonia**  
**WOLFE**  
 L1st United. CARELTON REAL ESTATE. L1st United. CARELTON REAL ESTATE. L1st United. CARELTON REAL ESTATE.

**312 Livonia**  
**WOLFE**  
 COUNTRY LIVING. A tree lined street with 1/2 acre site provides a beautiful country setting for this like new brick and aluminum ranch with large full basement. You will love this large family kitchen with door/wall to patio, three bedrooms, 1 1/2 baths and with an oversized two car garage. Excellent assumption. \$37,500.  
 HARRY S.

**312 Livonia**  
**WOLFE**  
 FAMILY ROOM. On beautifully landscaped 1/2 acre wooded lot backing to woods. 4 bedrooms, 2 1/2 baths, attached 2 car garage, fully carpeted and draped, formal dining room, beamed family room with full wall brick fireplace. Many extras including central air, gas BBQ, electric garage door opener, brick entryway. Shown by appointment only 3074 Bobrich Ave. \$59,900. 522-2669.

**312 Livonia**  
**WOLFE**  
 CENTRAL AIR. Spotless brick and aluminum family home with 3 large bedrooms, family room with fireplace, dining room, basement, plus first floor utility room. Carpeted thru-out. New 28' terrace, attached 2 car garage. EXCELLENT GARDEN AREA - and loaded with extras.  
 Red Carpet REALTORS 522-3500

**312 Livonia**  
**WOLFE**  
 STARTER HOMES. \$22,900 - Excellent assumption, a real dollhouse. Three bedrooms, brick front ranch, carpeted, complete with a two car garage.  
 \$22,500 - Settling estate. Three bedroom bungalow on tree lined street. Full basement.  
 \$23,900 - Full basement, 3 bedroom brick front ranch, large kitchen, fenced yard.  
 \$21,900 - 1/2 acre. Your own Ponderosa. Four bedrooms, large kitchen.  
 HARRY S.

**312 Livonia**  
**WOLFE**  
 TREAT THE KIDS. To a summer of fun in the inground pool of this 3 bedroom tri-level ranch with 1 1/2 baths, modern kitchen, quality carpeting and large family room. Professionally landscaped. All for only \$39,900. ML 59466. VINCENT N. LEE. THE #1 COMMISSION MULTI-LIST BROKER. L1st United. LEE. "Call Lee, and start packin'". 476-6161.

**312 Livonia**  
**WOLFE**  
 NEWLY WEDS OR RETIREES! Two bedroom ranch. Two car garage. Large lot. Low taxes. Farmington Hills. \$29,500.

**312 Livonia**  
**WOLFE**  
 ACRES. Location counts here. Nearly 10 acres just minutes from shopping and expressways. Horse barn and corral. Three bedroom ranch, den and family room. All in ravine setting. Southfield. \$81,900.

**312 Livonia**  
**WOLFE**  
 EASY LIVING. Leave the maintenance to some one else. Two room ground floor condominium with ravine view. Central air. Adult complex. \$27,500. Farmington Hills.

**312 Livonia**  
**WOLFE**  
 FOUR BEDROOMS. Brick ranch in Farmington Hills. Finished basement. Fenced yard. \$36,500.

**312 Livonia**  
**WOLFE**  
 First United. OMARG. Sanderson. 535-2720. 474-3000.

**312 Livonia**  
**WOLFE**  
 Chamberlain REALTORS. Southfield/Lathrup Village Office. 26840 Southfield Rd. at 11 Mile. 557-6700.

**312 Livonia**  
**WOLFE**  
 Red Carpet REALTORS. 522-3500.

**REALTOR WEEK APRIL 20-26**

**We salute our local REALTORS!**

**HOME OWNERSHIP: AN AMERICAN TRADITION**

**314 Plymouth**  
**PLYMOUTH TWP. NEW PRICE!**  
 ONE ACRE comes with this 2 bed room ranch with carpeting thru out. Full basement, 2 car garage. Price cut to \$22,900. Land contract possible. Call for details.  
**Red Carpet REALTORS** 522-3500

**314 Plymouth**  
 4 ACRES LOT IN PLYMOUTH Super 3 bedroom ranch with large living room and dining area. Family room, 1 1/2 baths, 2 1/2 car garage. Finished basement. Owner anxious. Reduced to \$44,900.  
**BEAUCHAMP SMITH & ASSOCIATES** 478-9900

**314 Plymouth**  
 BY OWNER, 4 bedroom colonial, 2 1/2 baths, 2 car attached garage, opener. Underground sprinkler. Rustic 2 story, beamed, foyer. Many extras. 455-8482

**314 Plymouth**  
**LAKE POINTE**, by owner, 3 bedroom brick ranch, 1 1/2 car garage, 1 1/2 baths, nicely treed lot \$36,500. (438) Brentwood, by appointment, 453-8484

**314 Plymouth**  
**DRIVE BY**  
 6541 Carriage Hill Dr., Canton (W. of Lilley, S. of Warren, W. of Bunker Hill). Canton - Plymouth area deluxe 3 bedroom brick ranch with central air, family room, fireplace, formal dining room, master bedroom bath, full basement, 2 car garage, plus a 7 1/4% assumable mortgage. For appointment, call Harry H. Jones 459-2200 or 477-1666 (C-060)

**316 Westland Garden City**  
 WESTLAND, 7% assumable mortgage. Immaculate 3 bedroom brick ranch, 1 1/2 baths. Sharp decor. Pool. \$27,900. By owner. Buyers only. 728-3873

**318 Redford**  
 EXCELLENT VALUE for economy minded couple looking for their first home. A charming 2 bedroom with 1st floor laundry and 1 1/2 car garage. Excellent assumption with 7% PAYMENT and low taxes. Call Bel-Men's Darryl. 522-3010

**318 Redford**  
 THREE bedrooms, screened patio porch, fenced yard. Low taxes, assumption. 7% mortgage. Owner \$21,900. 535-2288

**302 Birmingham Bloomfield**  
**BY PROFESSIONALS BLOOMFIELD**  
 Cozy 3 bedroom ranch with den, fireplace in living room. Large lot on quiet tree-lined street. Bloomfield schools \$38,500

**J. L. HUDSON Real Estate**  
 A TAKE IT EASY HOUSE... \$44,500  
 One Half Acre of Country Living in this three zoned heated Tri-Level, large family room, three bedroom, convenient layout, aluminum sided two car garage, excellent location, close to town. It's a must see

**JUST LISTED PLYMOUTH SCHOOL DISTRICT**  
 Spotless all brick 3 bedroom ranch with paneled family room and natural fireplace. Country kitchen with built in hutch & walk in pantry. All draperies & kitchen appliances included. 2 1/2 car cement block garage. Excellent assumption available at 7% \$39,900. Call Jack English. 453-0144

**Westdale "W" Co's PLYMOUTH TWP \$44,900**  
 Here's a well built custom home in country setting complemented by a 7 room brick colonial with a Florida room & attached garage. It has many advantages and easily relates to comfort, convenience & beauty.  
**Thompson-Brown** 261-5080

**Integrity REALTORS**  
 PRICED TO SELL, 3 bedroom brick ranch, finished basement, 2 car attached garage. \$28,900. Earl Keim Realty. 522-4777

**S. REDFORD**  
 A prestigious 5 bedroom home, perched on a ravine lot, 3 fireplaces, family room, finished rec. room, walk in pantry and more. Call Betty Karolak.  
**REAL ESTATE ONE** 274-9510

**REDUCED**  
 For a quick sale. Yes, this enchanting face brick home in Taylor has been reduced by a full \$1,000. 4 bedrooms, 2 1/2 baths, large modern kitchen, family room with fireplace, full basement, gas FA heat, carpeted throughout, attached 2 car garage. Close to schools and Southland shopping. Reduced to \$35,900 terms.  
**Summit** 427-3200

**TROY**  
 Charming 4 bedroom ranch with lovely family room and fireplace. Formal dining room and large living room for entertaining. \$52,950

**TRADE UP ELEGANCE**... \$44,900  
 Charming three bedroom Colonial, family room with fireplace, all nice sized rooms, attached two car garage, fully landscaped lot

**DELMONTE** 453-0144  
 1 Block W. of Lilley Rd. S of Ford Rd.  
 CITY OF PLYMOUTH New 3 bedroom home now available. Select your colors and carpeting. Contact Derin Construction Inc. 425-5700

**316 Westland Garden City**  
 LOTS OF ROOM to grow, grow and grow. Large newly decorated 4 bedroom family home in prime suburban area. 1 1/2 baths, garage, excellently landscaped. CALL TODAY TO SEE! \$31,900. Call Bel-Men's Ed. 522-3010

**LOW PRICE**  
 \$27,900  
 NICE HOUSE  
 4 Bedroom Ranch Full Basement 1 1/2 Baths EASY ASSUMPTION \$4600 Complete GOOD PAYMENTS \$276 per Month Complete Quick Occupancy  
 By Owner 728-9351

**REDFORD SOUTH**, beautiful brick home, 1 1/2 baths, new carpet throughout, finished basement, sharp kitchen with built in, central air, large yard with garage, patio & above ground pool. By owner. \$34,900. 255-9887

**WAYNE**  
 3 bedroom bungalow, carpeting, gas heat, garage, needs decorating. Make offer for easy assumption.  
**JAMMY** 537-1950

**LAKE PRIVILEGES**  
 IF you want country atmosphere with every convenience, see this impeccable 3 bedroom, 2 bath ranch. New carpeting and decorating. 1428 family room, large kitchen, close to Walnut Lake. Buyers only \$52,500. By Owner. 851-8670

**WOMAN TO WOMAN DON'T SETTLE FOR LESS**... \$52,900  
 Beautifully done large four bedroom Colonial. Kitchen built-ins, natural fireplace in family room, attached two car garage, extra sized lot, attractively landscaped

**HAROLD real estate FISCHER**  
 1108 S. Main St., Plymouth 455-5100

**WESTLAND**  
 4 bedroom colonial, family room, enclosed terrace, finished rec. room in basement, 2 baths, 2 one half baths, 2 car garage, central air. Call Don Marsh, 459-2200 or 455-3467 (W-050)

**WESTLAND SPECIAL!**  
 Only \$27,500 3 bedroom brick ranch, 2 baths, your own night club in basement. 2 car garage. 348-8700  
**BRUCE ROY REALTY, INC.**

**WOLFE**  
 33235 Seven Mile 427-0733  
 S. REDFORD, by owner, 3 bedroom, 1 1/2 baths, brick ranch, 18 family room with beamed cathedral ceiling and natural fireplace, patio and 2 car garage. \$37,900. Call Betty Karolak. 537-3167

**REAL ESTATE ONE** 274-9510  
 BEAUTIFUL 2 bedroom, aluminum attached breezeway and garage. Park like big yard. Double lot. \$19,900 \$4600 assumes \$211 month mortgage. Schoolcraft. Outer Drive area. 255-7446

**BLOOMFIELD TWP**, walk to St. Regis, Marian, Brother Rice. 4 bedroom colonial, many extras. By owner. Buyers only \$75,900 446-7369

**DO YOU HAVE COUNTRYTIS**... \$65,000  
 A mini horse farm, five acres with excellent three bedroom brick ranch, full basement. Three car garage and workshop, plus large addition on garage for wagon tractor and hay storage, four stall horse barn with electricity and water, nice pond, fence, beautifully landscaped, be a junior farmer, best terms.

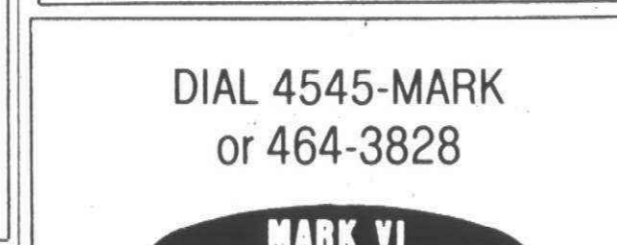

Sharp home! 3 bedrooms, 2 tiled baths, formal dining room, carpeting throughout. 26 x 15 recreation room. 419 Blunk.

**WESTDALE "W" Co's**  
 IMMEDIATE Occupancy, beautiful 3 bedroom colonial with family room, natural fireplace, large corner lot, carpeting, 1 1/2 baths, full basement, utility shed and many other extras too numerous to mention. Priced to sell. \$34,900 326-1922

**318 Redford**  
 FOR THE LARGE FAMILY, 3 bedroom, many extras, excellent condition. Near all schools including perochial. Open Sun. 2-5. 333-6279

**REDFORD TOWNSHIP NEED BEDROOMS??**  
 4 BEDROOMS... in this 2 story home. Full basement, carpet thru out, large enclosed porch and 1 1/2 baths. Only \$22,900.

**RED CARPET REALTORS** 522-3500  
 REDFORD TWP. by owner, 1 1/2 car garage, fenced yard. 538-6109

**BIRMINGHAM BLOOMFIELD**  
 FRANKLIN and Lone Pine area Redwood and brick Tri Level, 3100 sq. ft. on 1/4 private acre. \$42,224. \$99,500. Buyers only. 342-2220

**JLH REALTY**  
 607 S. MAIN ST. PLYMOUTH 453-2210

**DIAL 4545-MARK or 464-3828**  
**MARK VI REAL ESTATE**

**George SMITH Realty Inc.**  
 THE SPIRIT OF '75 IT'S FOR REAL! --REAL PROPERTY  
 PLYMOUTH - REAL VALUES

**Red Carpet REALTORS** 522-3500  
 MUST SELL! Asking \$31,900 or make offer 3 bedroom brick ranch with finished basement, breezeway, 2 car garage. Assume 5 1/4% mortgage or 7% land contract. 534-4588

**RED CARPET REALTORS** 522-3500  
 HURRY-THE ICE is just about off the lake, it will soon be time to go swimming off the island on Long Lake. This sharp ranch has a full basement and kitchen kaded with copboards plus other features. Call now, it won't last at \$37,500.

**304 Farmington West Bloomfield**  
 THE ULTIMATE  
 Stunning 2 story colonial featuring 4 bedrooms, dining room, family room with fireplace, 2 1/2 baths, kitchen built ins, partitioned basement, attached garage and much more. In lovely Farmington Hills Sub. For \$69,900. Stop in or call BOB GERICH at 476-9100

**MCKEON MCKEON REAL ESTATE, INC.**  
 PLYMOUTH 500 S. MAIN 453-6800

**OUR SALES PERFORMANCE DEMANDS YOUR CONSIDERATION IN ANY FUTURE REAL ESTATE TRANSACTIONS**  
 ALL OF OUR SALES STAFF ARE PLYMOUTH AREA RESIDENTS!  
 PAT O'HARA MANAGER  
 NEIL BOYLE AL DeZELL  
 RON BRODZIK DICK PURFY  
 PAT STOKES ED CAMILLERI

**NEWLY LISTED!**  
 40703 ORANGELAWN \$41,900  
 4 bedroom Colonial, country kitchen, 20x15 family room with natural fireplace, 2 car garage, covered patio, close to Allen School. Call 453-4840

**RED CARPET REALTORS** 522-3500  
 MUST SELL! Asking \$31,900 or make offer 3 bedroom brick ranch with finished basement, breezeway, 2 car garage. Assume 5 1/4% mortgage or 7% land contract. 534-4588

**RED CARPET REALTORS** 522-3500  
 HURRY-THE ICE is just about off the lake, it will soon be time to go swimming off the island on Long Lake. This sharp ranch has a full basement and kitchen kaded with copboards plus other features. Call now, it won't last at \$37,500.

**chamberlain**  
 Farmington Hills  
 Beautiful sparkling 3 bedroom colonial on a nice wooded lot. Note size of master bedroom, 12 x 18'. Finished rec. room, 1 1/2 baths, 2 car attached garage. Call John Kare 477-6300 or 348-9664 (T-041)

**CHARM AND CHARACTER** are found within this gracious home, located in Plymouth Twp. on almost 1/2 acre lot. Three large bedrooms, spacious formal dining, warm country kitchen, Maintenance free exterior. A real heart stealer. For appointment call 453-6800  
 \$43,500.00

**FOR YOUR CONVENIENCE OUR ALTERNATE PHONE NUMBER IS**  
 464-3828  
 39319 PLYMOUTH RD., LIVONIA

**CANTON COUNTRY** \$69,900  
 9 1/2 acres and 4 bedroom custom 2 story home come and see this tremendous value for a large family. It has 1 1/2 baths, full basement, and 2 car garage too. Excellent Land Contract terms make for a good investment. Call to make your appointment-453-4840

**RED CARPET REALTORS** 522-3500  
 MUST SELL! Asking \$31,900 or make offer 3 bedroom brick ranch with finished basement, breezeway, 2 car garage. Assume 5 1/4% mortgage or 7% land contract. 534-4588

**RED CARPET REALTORS** 522-3500  
 HURRY-THE ICE is just about off the lake, it will soon be time to go swimming off the island on Long Lake. This sharp ranch has a full basement and kitchen kaded with copboards plus other features. Call now, it won't last at \$37,500.

**LEE**  
 "Call Lee, and start packing" 476-6161

**WHAT A FIND!!!**  
 Large living room, ledgerrock fireplace in living room, master bedroom with doorwall to balcony to admire your almost 2 acre domain. Four bedroom tri-level, large country kitchen, walkout basement and much more. Call for an appointment.  
 \$41,900

**EARL KEIM REALTY**  
 of Plymouth, Inc  
 PLYMOUTH AREA  
 IDEAL FOR WORKING COUPLE! 2 bedrooms, brick construction, close to downtown Plymouth, full basement, central air & 1 1/2 baths. Only \$30,500 Call 453-0012

**WELCOME FIA & VA**  
 All aluminum two or three bedroom with formal dining room, 1 1/2 car garage, enclosed porch and completely fenced yard. Asking \$21,900. Call now, 721-8400.

**RED CARPET REALTORS** 522-3500  
 MUST SELL! Asking \$31,900 or make offer 3 bedroom brick ranch with finished basement, breezeway, 2 car garage. Assume 5 1/4% mortgage or 7% land contract. 534-4588

**RED CARPET REALTORS** 522-3500  
 HURRY-THE ICE is just about off the lake, it will soon be time to go swimming off the island on Long Lake. This sharp ranch has a full basement and kitchen kaded with copboards plus other features. Call now, it won't last at \$37,500.

**chamberlain**  
 Farmington Hills  
 Beautiful sparkling 3 bedroom colonial on a nice wooded lot. Note size of master bedroom, 12 x 18'. Finished rec. room, 1 1/2 baths, 2 car attached garage. Call John Kare 477-6300 or 348-9664 (T-041)

**GOOD ASSUMPTION**, central air conditioning and chalet front colonial with deluxe four bedroom design with family room & fireplace. Owner takes pride in tasteful and meticulous interior. Our pleasure to show  
 \$54,000.  
 HIGHEST GROSS monthly rental income of any unit in its market \$650.00 Lower unit can be your own apartment with 3 full bedrooms, formal dining, fireplace and 2 car garage for you and separate rental units. Whatever your pleasure --to rent all or part.  
 \$43,900.  
 OPPORTUNITIES AWAIT YOU--CALL OUR FULLY STAFFED COMMERCIAL DEPARTMENT 453-6800

**NORTHVILLE OFFICE** 330 NORTH CENTER ST. 349-5600  
**PLYMOUTH OFFICE** 1115 S. MAIN ST. 453-0012

**Chamberlain REALTORS**  
 LAKE FRONT HOME  
 \$12,000 Down on land contract. 5 minutes from US-23 or I-95. 1/2 hour from suburbs. Year round home with two bedrooms, dining room, fireplace and garage. Plus sandy beach and boat. On Ore Lake. Asking \$44,900. Hurry!! Call 721-8400.

**RED CARPET REALTORS** 522-3500  
 MUST SELL! Asking \$31,900 or make offer 3 bedroom brick ranch with finished basement, breezeway, 2 car garage. Assume 5 1/4% mortgage or 7% land contract. 534-4588

**RED CARPET REALTORS** 522-3500  
 HURRY-THE ICE is just about off the lake, it will soon be time to go swimming off the island on Long Lake. This sharp ranch has a full basement and kitchen kaded with copboards plus other features. Call now, it won't last at \$37,500.

**chamberlain**  
 Farmington Hills  
 Beautiful sparkling 3 bedroom colonial on a nice wooded lot. Note size of master bedroom, 12 x 18'. Finished rec. room, 1 1/2 baths, 2 car attached garage. Call John Kare 477-6300 or 348-9664 (T-041)

**OPPORTUNITIES AWAIT YOU--CALL OUR FULLY STAFFED COMMERCIAL DEPARTMENT 453-6800**

**NORTHVILLE OFFICE** 330 NORTH CENTER ST. 349-5600  
**PLYMOUTH OFFICE** 1115 S. MAIN ST. 453-0012

**Westland/Livonia Office** 34215 Ford Road Westland, Michigan 48185 721-8400

**Plymouth/Northville Office** 1360 S. Main Plymouth, Michigan 48170 455-5200

**Livonia/Farmington Office** 19590 Middlebelt Road Livonia, Michigan 48152 476-9100

**chamberlain**  
 Farmington Hills  
 Beautiful sparkling 3 bedroom colonial on a nice wooded lot. Note size of master bedroom, 12 x 18'. Finished rec. room, 1 1/2 baths, 2 car attached garage. Call John Kare 477-6300 or 348-9664 (T-041)

**304 Farmington West Bloomfield**

FARMINGTON. By owner. 3 bed room brick ranch. 1 1/2 Baths. full basement. stove, refrigerator. Possible Land Contract. Open Sunday. \$32,500.

FARMINGTON MEADOWS. Super sharp 4 bedroom, 3 level, with natural fireplace in huge family room, plus adjoining den or rec. room in beautiful area lovingly decorated & spotlessly maintained. Elegantly landscaped yard. huge trees, wonderful tranquility. Call Bob Smith 477-6300 or 476-0837 (A-054).

Westdale "W" Co's

SOUTHERN COLONIAL on a hill. 3 bedrooms. circular driveway, ravine. automatic sprinkler. Circular staircase. formal living and dining room. paneled study. paneled family room with built-in bar. TV and stereo. natural fireplace. first floor laundry room. beautiful kitchen and breakfast room. Central air. 2 1/2 car garage. \$135,000. By owner. Buyers only. 626-0548

FARMINGTON'S FLORAL PARK. Nestled among towering trees in Farmington's Floral Park is this cozy, immaculate 2 bedroom home. Large living room, master bedroom, oversized 2 car garage & breezy Florida room. Call Vince Vorhagen 477-6300 or 522-1258 (H-039).

Westdale "W" Co's

**304 Farmington West Bloomfield**

Farmington Hills. At its finest in this immaculate move-in condition 3 bedroom ranch. 2 full baths, central air, water softener, power humidifier, electronic filter. Barbecue grill all on 3/4 acre lot. Call John Kare 477-6300 or 348-9664 (S-050).

Westdale "W" Co's

DRIVE BY 29900 Ravenscroft, Farmington Hills (W of Farmington Rd., N. of 13 Mile Rd). This is for you, beautiful 4 bedroom colonial, storage galore, family room & study. For appointment, call Frank Denney 477-6300 or 493-1835 (R-042).

Westdale "W" Co's

LAKE PRIVILEGES. Cape Cod brick 3 bedrooms, large living room with fireplace. Formal dining room, basement, and attached garage on 120 x 130 ft. lot. \$24,980. Hitchcock Gallery of Homes. 388-1870

FARMINGTON HILLS SPRING. IS HERE, and it's not too late to spring into spring with this 3 bedroom aluminum sided ranch! Give yourself time to plant a garden in the close to 2 acre lot! Enjoy country living during the spring and summer! Low \$20's.

ELLIS 476-1700

**304 Farmington West Bloomfield**

Farmington Hills. This 5 bedroom Colonial offers spacious & modern living, family room features stone fireplace. 2 1/2 baths, library hide-a-way. Offered to most discriminating buyer at \$112,900. Call Vince Vorhagen, 477-6300 or 522-1258 (C-056).

Westdale "W" Co's

FARMINGTON HILLS. 3 bedroom brick ranch on large shaded lot. 12 Mile - Middlebelt area. \$52,500. By appointment. 474-2813

FARMINGTON HILLS \$23,500. THREE BEDROOMS in this Farmington Hills ranch, carpeted 23 ft living room, good size kitchen and large lot. Land contract available. Call for details.

Red Carpet REALTORS 522-3500

Farmington Hills. St. Francis North of Grand River attractive brick front ranch, large living room with natural fireplace. 2 large bedrooms, finished basement with bar, reduced to \$26,900. Owner transferred.

TOWER 478-5090

**304 Farmington West Bloomfield**

W. BLOOMFIELD. Deerfield Village. 4 bedroom pillared colonial, den plus family room, central air. New dishwasher, disposal. Immediate occupancy. \$81,500. By owner. 851-1849 or 647-7514

WEST BLOOMFIELD. By owner. Sharp. 4 bedroom, 2 1/2 bath, gas heat, custom brick Ranch with marble entrance and fireplace. 3/4 car heated attached garage, central air, electric air cleaner, sprinkler, burglar and fire system. Circular drive, park like. 1 1/2 acre setting. Many extras, \$79,000. Call after 5 PM, weekdays, anytime weekends. Buyers only. Open Saturday and Sunday. 851-9638

WEST BLOOMFIELD LAKE ESTATES. LAKE PRIVILEGES. 4 bedroom colonial, 2 1/2 baths, family room with cathedral ceilings. 1st floor laundry room. Complete, ready to move in. Every extra, \$97,500.

682-2639

306 Southfield Lathrup. SOUTHFIELD. 3 bedroom brick ranch. 1 1/2 baths, central air conditioning, carpeting, newly decorated. Buyers only \$32,500. 354-1430

FIRST OFFERING. Super Colonial, master bedroom, with dressing room, gorgeous family room with natural fireplace. Move-in condition. Call Joan Wheeler REAL ESTATE ONE 559-2300

**306 Southfield Lathrup**

SOUTHFIELD. BY OWNER. You'll be proud to own this home. We are Beautiful 3 bedroom brick Ranch. 1 1/2 baths, sunken family room with full brick wall fireplace. U shaped kitchen with all built-ins including dishwasher. Custom made shutters on all windows. Unique and clean finished rec room in basement with barn sliding door and carpeting. Central air, furnace humidifier, carpeted throughout. 2 car attached garage with 2 openers, storage shed, gas barbecue beautiful landscaped lot with trees. Prime location. Walk to schools and Beech Wood rec center. Buyers only. \$46,000. 357-5229

BIRMINGHAM SCHOOLS. 4 bedroom colonial. Central air, air filter and humidifier. 2 1/2 baths, paneled family room with fireplace, carpeting throughout, garage door opener, fenced yard. Walk to schools. Low \$60's. 646-7171

SOUTHFIELD. Birmingham schools. 4 bedrooms, 2 1/2 baths. First floor laundry, huge family room. Interior decorated. Mid \$60's. 644-8360

**306 Southfield Lathrup**

BEACON Square. 5 bedroom Cape Cod. 2 1/2 baths, family room, fireplace, screened porch. gas grill. \$81,900. By Owner. 352-0943

WHAT ASSETS! In this beautiful 3 bedroom, 2 bath, Tri-Level home, with both family and recreation room. Extra features include, large walk-in closets, patio with gas grill, attic fan, 2 car attached garage. The perfect combination of space, attractiveness and convenient location. Many, Many More Pleasures. Surprises. All for only \$58,900. Call Today! 644-8700

Realtors Birmingham

**306 Southfield Lathrup**

Southfield Assumption. 3/4 ACRE. SHARP. 3 bedroom ranch on 1/2 acre with circle drive. Fireplace in 22' living room plus 2nd fireplace in 25' family room, dining room, plus large kitchen. 1 1/2 baths. attached garage. \$32,900.

Red Carpet REALTORS 522-3500

NEW 3 bedroom brick ranch, full basement, formal dining room, spacious kitchen, family room, large treed lot. 356-4955

**306 Southfield Lathrup**

SOUTHFIELD \$59,500. Deluxe brick ranch with 3 or 4 bedrooms, fireplace in living room & recreation room. 2 full baths, estate size property. Call Harvey Beadle 477-6300 or 531-7906 (R-039).

Westdale "W" Co's

SOUTHFIELD. Twykingham Village. Four bedroom Colonial, central air, family room, library. Two level wood deck. By owner. \$72,900. Buyers only. 354-0121

**306 Southfield Lathrup**

Cranbrook Village. OPEN SAT-SUN 2-5 PM. New on market 3 bedroom brick ranch with fireplace, large paneled air conditioned family room. Carpeting throughout. Finished basement with wet bar. Many extras, including private patio. Walking distance to schools. By owner. \$42,900. For appointment call weekdays 359-2497

SOUTHFIELD. new 3 bedroom ranch. 1 1/2 baths, family room, fire. 30 357-9620 or 455-8470

**FARMINGTON'S FLORAL PARK**

Nestled among towering trees in Farmington's Floral Park is this cozy, immaculate 2 bedroom home. Large living room, master bedroom, oversized 2 car garage & breezy Florida room. Call Vince Vorhagen 477-6300 or 522-1258 (H-039).

Westdale "W" Co's

**FARMINGTON HILLS SPRING**

IS HERE, and it's not too late to spring into spring with this 3 bedroom aluminum sided ranch! Give yourself time to plant a garden in the close to 2 acre lot! Enjoy country living during the spring and summer! Low \$20's.

ELLIS 476-1700

**Red Carpet REALTORS**

Farmington Hills. St. Francis North of Grand River attractive brick front ranch, large living room with natural fireplace. 2 large bedrooms, finished basement with bar, reduced to \$26,900. Owner transferred.

TOWER 478-5090

**306 Southfield Lathrup**

SOUTHFIELD. 3 bedroom brick ranch. 1 1/2 baths, central air conditioning, carpeting, newly decorated. Buyers only \$32,500. 354-1430

FIRST OFFERING. Super Colonial, master bedroom, with dressing room, gorgeous family room with natural fireplace. Move-in condition. Call Joan Wheeler REAL ESTATE ONE 559-2300

**EARL KEIM REALTY**

EARL KEIM REALTY of Dearborn Inc.

NEW LISTING Clean 3 bedroom ranch, carpeted throughout, gas forced air heat, built-in oven and range, dishwasher, 2 car garage. Clarenceville School District, close to Livonia Mall, see this soon! PRICE \$21,900 Call 261-1600

COLONIAL 4 large bedrooms, family room with natural fireplace and built-in air conditioning unit, complete carpeting, full basement, 2 car attached garage. PRICE \$65,500 Call 261-1600

LIKE NEW And all the work has been done, just relax and enjoy this 2 year old brick ranch, features 3 bedrooms, 2 full baths, family kitchen, family room with natural fireplace, attached 2 car garage, new carpeting, full basement, terrace, barbecue and quality pool. PRICE \$47,500 Call 261-1600

MINT CONDITION 3 bedroom brick ranch, full basement with recreation room, modern kitchen with built-in oven and range, fenced yard, very neat and attractively decorated, garage. PRICE \$28,900 Call 261-1600

ROSEDALE GARDENS Face brick ranch, family room, 2 car block garage, natural fireplace in living room. PRICE \$34,900 Call 261-1600

SPACIOUS Prestige home, Normandy roof, 2 bedrooms, 1 1/2 baths, brick ranch, huge living room, fireplace, dining room, den and music rooms could be bedrooms, large recreation room with bar and fireplace, attached garage, expansion attic, easy mortgage assumption, on 3 lots in Rosedale Gardens, walk to all conveniences. PRICE \$45,900 Call 261-1600

LIVONIA OFFICE 15707 FARMINGTON RD. LIVONIA 261-1600

the HELPFUL People!

**WILLIAM DECKER, REALTORS**

670 Main Street  
Plymouth, Michigan 48170

455-8400

*Want*

**REAL prospects,  
REAL-istic pricing,  
REAL peace of mind?**

There's a smart way to get all three when you're ready to sell your Home. Financially qualified prospects...not just a lot of traffic from casual lookers. Pricing recommended by people who know the market, and what price will profitably sell your house faster. And wonderful peace-of-mind. Because you'll be relieved of all the involved details, paperwork, advertising and tedious hours of showing prospects through the house. You'll know the job is being done expertly, under a strict code of ethics, when you...

**List with William Decker REALtors**

THE PICTURE IS NICE, BUT THE INSIDE IS EVEN NICER! A rare find a truly family sized ranch home and it is in immaculate condition! 3 king sized bedrooms, fine Livonia area, dining room, family room with fireplace, linette, Florida room, den, recreation room, better see it. \$55,900

TASTEFULLY DECORATED and spacious 3 bedroom Livonia Quad, large family room, new Central Air, carpeting, built-ins, garage. \$48,500

THE OWNER'S PRIDE IN THIS HOME can be seen. 3 bedroom ranch in Livonia, carpeting, beautiful recreation room, 2 car garage. \$36,900

ELEGANT PILLAR COLONIAL in Prime area of Livonia. 4 bedrooms 2 1/2 baths, family room, formal dining, carpeting, first floor laundry, \$61,900

IMMEDIATE OCCUPANCY on this 4 bedroom 2 bath Livonia Ranch due to transfer, built-ins, carpeting, recreation room, garage. \$39,900

TRANSFERRED, Call us for service in all 50 states.

**Martin, Ketchum & Martin REALTORS** 522-0200  
31172 FIVE MILE at MERRIMAN

3 BEDROOM CUSTOM BUILT RANCH ON YOUR LOT.

Regular \$17,500 from

**\$16,636 COMPLETE!**

WITH NO OWNER PARTICIPATION  
OTHER MODELS FROM \$14,500 WITH MINOR OWNER PARTICIPATION

SEE THIS AND MANY OTHER MODELS ON SALE THIS WEEK DAILY AND SATURDAY 12-6.

NOT A PRE-FAB SHELL OR DO-IT-YOURSELF HOUSE, BUT A CONVENTIONAL BUILT CUSTOM HOME.

**RAINBOW HOMES INC. 538-2550**  
17394 BEECH-DALY 2 Bks N. of 6 MI

**WHAT YOU SEE IS WHAT YOU GET!**

When you buy an existing house from a Real Estate One Sales Associate, you'll know that what you see in that house, in the plumbing, electrical and heating systems works. Because if it's a Real Estate One listing meeting certain qualifications, you will receive a FREE one year home service contract that says if anything goes wrong with these basic systems, the home service company will repair or replace it for nothing. Now, isn't that better than shedding tears? Only from Real Estate One



**DEARBORN HEIGHTS**  
24152 McDONALD. OPEN SUNDAY 2-5. Nice neat 3 or 4 bedroom aluminum sided bungalow in good area. Immediate occupancy, owner transferring. Will go VA. Dearborn Heights. Call 477-1111 (31168)

**INKSTER**  
Enjoy the quiet of this 2 bedroom starter home on a winding street overlooking park area. Watch the birds and bunnies from your dining room window. Enjoy the apple blossoms in the spring. \$20,900 Call 274-9510 (30990)

**WESTLAND**  
Exceptional home. Quad with 3 bedrooms up. Mother-in-law apartment, lower level. 1/2 acre, horse allowed. Built 1972. Good assumption. \$33,900 Call 274-9510 (31323)

Three bedroom brick ranch with fireplace, family room, full basement, 2 car garage and good assumption. \$35,900 Call 261-2600 (30831)

**LIVONIA**  
Enjoy country living in the city! This cozy and clean 3 bedroom ranch with 2 car garage offers a large lot with mature trees. Excellent neighborhood. Immediate occupancy. \$26,900 Call 261-0700 (30653)

A superbly scenic area nestles this attractively decorated condominium located in prime Livonia area and including carport, basement and private balcony. Air conditioning and pool too! \$26,900 Call 261-0700 (31248)

Beautiful executive custom 4 bedroom brick quad-level on gorgeous ravine lot in Burton Hollow Estates. Tastefully decorated with formal dining room, family room with fireplace and doorwall leading to large patio overlooking treed ravine. Enclosed terrace, finished recreation room and attached garage. \$75,900 Call 261-0700 (31053)

**LIVONIA**  
Charming older home with all modern improvements. Large dining room, 2 bedrooms, all kitchen appliances, breakfast nook, natural fireplace and 2 car garage. \$37,000 Call 261-0700 (31203)

**LIVONIA**  
Lovely 4 bedroom colonial with 2 1/2 baths, formal dining room, family room with fireplace, 1st floor laundry room, central air and more. Located on 1/2 acre lot in beautiful Nottingham Woods. \$84,400 Call 261-0700 (30445)

Very desirable 3 bedroom home with natural fireplace in living room, 2 1/2 car garage, brick barbecue and more all on a beautiful 1 acre park-like setting. \$38,500 Call 261-0700 (30172)

Rosedale Gardens-3 bedroom ranch in one of Livonia's most popular subdivisions. Finished basement, 2 1/2 car garage, fireplace in large living room, country kitchen with dishwasher, excellent as assumption and large fenced lot. \$35,900. Call 261-0700 (29817)

**LIVONIA**  
Beautiful cleared, level 1/2 acre building site in prime area of Livonia. Close to schools, recreation and shopping. \$11,500 Call 455-7000 (70484)

**REDFORD**  
Be sure to see this sensible economical home. Perfect for today's tight budgets. Has dining room and full basement. Near schools, shopping. Aluminum makes for maintenance free. Terrace. \$23,900 Call 261-0700 (31268)

Four bedroom home with formal dining room, all new carpeting, newly decorated throughout in beautiful area. Immediate occupancy, owner transferred. \$17,900 Call 261-2600 (28759)

Ideal maintenance free 2 bedroom starter home with 2 car garage. Buy on Land Contract-low taxes. \$19,900 Call 261-2600 (31056)

Good starter and retiree home. Two bedroom brick ranch with 1 1/2 car garage and modern kitchen. \$24,500 Call 477-1111 (30873)

**PLYMOUTH**  
Three apartment income in the heart of town. Close to schools and shopping. City certification of plumbing, heating, electrical and structural all approved. \$49,950 Call 455-7000.

**SOUTH LYON**  
Country living in horse country with this custom 3 bedroom ranch in prestigious area. Two full baths, family room, fireplace, full basement and oversized 2 1/2 car garage on a large lot. Quality galore. Get your snowmobile ready and move on in. \$50,000 Call 261-2600 (29128)

**GARDEN CITY**  
Immaculate 3 bedroom ranch with central air, large walk-in closets, formal dining room with doorwall, 1 1/2 baths plus wall to wall carpeting. \$32,900 Call 326-2000.

**DEARBORN**  
Three bedroom brick home in quiet Dearborn. Full basement, 2 car garage and more. Near parks, schools and shopping. Public transportation close. \$25,900 Call 326-2000 (31158)

**NOVI**  
Ten Mile and Meadowbrook area. Move in. Nice ranch condominium with large master bedroom, enclosed redwood deck, private pool, picnic area and tot lot. \$25,900 Call 455-7000.

**Real Estate One.**

**Equal Housing Opportunity**

**Michigan's Largest**

306 Southfield Lathrup TWYCKINGHAM VILLAGE Beautiful Colonial with 4 large bedrooms on professionally landscaped lot with slate patio & gas fireplace...

309 Northville-Novl NOVI LAKEFRONT Like new 4 bedrooms, 2 baths, family room with fireplace, carpet throughout...

322 Condominiums For Sale TAX CREDIT AT BARKRIDGE GLEN Plus Other Great Savings Offered...

332 Mobile Homes For Sale DETROIT 1970, 12 x 40, 2 bedroom stove, refrigerator, washer, carpeting Excellent condition...

340 Lake-Resort Property For Sale BEACH PRIVILEGES On Brighton Lake, adds to the value of this new 3 bedroom ranch...

352 Commercial Industrial SMALL office building in Rochester, Brick, 5 rooms & bath \$23,500 with \$3500 down...

400 Apartments to rent SOUTH Lyon, 2 bedroom apartment, draper, carpeting, appliances and heat included at \$285 month...

400 Apartments to rent Village Manor Apts. Oxford Area New units available now. Also renovations taken for August & September occupancy...

WESTLAND NEAR HUDSON'S Spacious 2 bedroom Apts., carpeted, air conditioned, all kitchen appliances \$195 plus security...

308 Rochester-Troy TROY COLONIAL 4 bedroom built in 1972 with family room and fireplace 2 1/2 baths, central air and car garage...

311 Homes For Sale Oakland County WIXOM, by owner 3 bedroom ranch, family room, fireplace, 2 car garage. Many extras, \$43,900...

REDFORD TWP. Apartment Condo, 1 bedroom, air conditioned. Low taxes and monthly maintenance. Near shopping and public transportation...

SMILE We have listings on numerous SINGLE and DOUBLE WIDE MOBILE HOMES in Ypsilanti, Belleville, Plymouth, and Wixom...

342 Lakefront Property WEST BLOOMFIELD Middle Straits Lake Privileges Almost new 3 bedroom ranch with 1 1/2 baths, carpeting, thermo windows...

356 Investment Property For sale FORMER Michigan resident has interest in local limited partnership for sale also attractive Arizona investment land with low down payment & tax shelter...

WALDEN WOOD IN SOUTHFIELD Extra Spacious 1 & 2 Bedroom Apartments. Townhouses RENT from \$290 Month Offering a complete complement of conveniences and services...

Bloomfield COUNTRY MANOR 334-6236 FARMINGTON HILLS Just completed, one bedroom apartment. Central air, appliances, carpeting, drapes...

CHURCHILL SQUARE APPTS. TROY'S finest 1 bedroom apartment includes dishwasher, carpeting, full size washer and dryer in each apartment...

ROCHESTER North area, 3 bedroom ranch, over 4 acres, 2 fireplaces, 2 baths, 2 car garage, screened in porch, open basement, rustic kitchen, American interior \$49,800...

ROYAL OAK N. Blair, S. of 13 Mi. W. of Rochester, 2 1/2 car garage, 4 bedrooms, finished basement, finished kitchen, screened porch, nicely landscaped...

NOVI Old Orchard, 7 1/4% assumable, 3 bedroom, family room, 1 1/2 baths, fenced patio, \$38,900 year around around pool...

SMILE We have listings on numerous SINGLE and DOUBLE WIDE MOBILE HOMES in Ypsilanti, Belleville, Plymouth, and Wixom...

342 Lakefront Property WEST BLOOMFIELD Middle Straits Lake Privileges Almost new 3 bedroom ranch with 1 1/2 baths, carpeting, thermo windows...

356 Investment Property For sale FORMER Michigan resident has interest in local limited partnership for sale also attractive Arizona investment land with low down payment & tax shelter...

WALDEN WOOD IN SOUTHFIELD Extra Spacious 1 & 2 Bedroom Apartments. Townhouses RENT from \$290 Month Offering a complete complement of conveniences and services...

Bloomfield COUNTRY MANOR 334-6236 FARMINGTON HILLS Just completed, one bedroom apartment. Central air, appliances, carpeting, drapes...

CHURCHILL SQUARE APPTS. TROY'S finest 1 bedroom apartment includes dishwasher, carpeting, full size washer and dryer in each apartment...

Winkleman REAL ESTATE 649-3510 BY owner Rochester area 3 bedroom ranch 2 1/2 car attached garage, new carpeting, tastefully decorated thru-out, reduced for quick sale \$29,900 Call for app. Buyers only 652-4638

WALLED LAKE Dandy modern 3 bedroom aluminum ranch, large lot, full price only \$19,000, with \$2000 down 349-8700 BRUCE ROY REALTY INC.

NOVI Old Orchard, 7 1/4% assumable, 3 bedroom, family room, 1 1/2 baths, fenced patio, \$38,900 year around around pool...

SMILE We have listings on numerous SINGLE and DOUBLE WIDE MOBILE HOMES in Ypsilanti, Belleville, Plymouth, and Wixom...

342 Lakefront Property WEST BLOOMFIELD Middle Straits Lake Privileges Almost new 3 bedroom ranch with 1 1/2 baths, carpeting, thermo windows...

356 Investment Property For sale FORMER Michigan resident has interest in local limited partnership for sale also attractive Arizona investment land with low down payment & tax shelter...

WALDEN WOOD IN SOUTHFIELD Extra Spacious 1 & 2 Bedroom Apartments. Townhouses RENT from \$290 Month Offering a complete complement of conveniences and services...

Bloomfield COUNTRY MANOR 334-6236 FARMINGTON HILLS Just completed, one bedroom apartment. Central air, appliances, carpeting, drapes...

CHURCHILL SQUARE APPTS. TROY'S finest 1 bedroom apartment includes dishwasher, carpeting, full size washer and dryer in each apartment...

Winkleman REAL ESTATE 649-3510 BY owner Rochester area 3 bedroom ranch 2 1/2 car attached garage, new carpeting, tastefully decorated thru-out, reduced for quick sale \$29,900 Call for app. Buyers only 652-4638

WALLED LAKE Dandy modern 3 bedroom aluminum ranch, large lot, full price only \$19,000, with \$2000 down 349-8700 BRUCE ROY REALTY INC.

NOVI Old Orchard, 7 1/4% assumable, 3 bedroom, family room, 1 1/2 baths, fenced patio, \$38,900 year around around pool...

SMILE We have listings on numerous SINGLE and DOUBLE WIDE MOBILE HOMES in Ypsilanti, Belleville, Plymouth, and Wixom...

342 Lakefront Property WEST BLOOMFIELD Middle Straits Lake Privileges Almost new 3 bedroom ranch with 1 1/2 baths, carpeting, thermo windows...

356 Investment Property For sale FORMER Michigan resident has interest in local limited partnership for sale also attractive Arizona investment land with low down payment & tax shelter...

WALDEN WOOD IN SOUTHFIELD Extra Spacious 1 & 2 Bedroom Apartments. Townhouses RENT from \$290 Month Offering a complete complement of conveniences and services...

Bloomfield COUNTRY MANOR 334-6236 FARMINGTON HILLS Just completed, one bedroom apartment. Central air, appliances, carpeting, drapes...

CHURCHILL SQUARE APPTS. TROY'S finest 1 bedroom apartment includes dishwasher, carpeting, full size washer and dryer in each apartment...

Winkleman REAL ESTATE 649-3510 BY owner Rochester area 3 bedroom ranch 2 1/2 car attached garage, new carpeting, tastefully decorated thru-out, reduced for quick sale \$29,900 Call for app. Buyers only 652-4638

WALLED LAKE Dandy modern 3 bedroom aluminum ranch, large lot, full price only \$19,000, with \$2000 down 349-8700 BRUCE ROY REALTY INC.

NOVI Old Orchard, 7 1/4% assumable, 3 bedroom, family room, 1 1/2 baths, fenced patio, \$38,900 year around around pool...

SMILE We have listings on numerous SINGLE and DOUBLE WIDE MOBILE HOMES in Ypsilanti, Belleville, Plymouth, and Wixom...

342 Lakefront Property WEST BLOOMFIELD Middle Straits Lake Privileges Almost new 3 bedroom ranch with 1 1/2 baths, carpeting, thermo windows...

356 Investment Property For sale FORMER Michigan resident has interest in local limited partnership for sale also attractive Arizona investment land with low down payment & tax shelter...

WALDEN WOOD IN SOUTHFIELD Extra Spacious 1 & 2 Bedroom Apartments. Townhouses RENT from \$290 Month Offering a complete complement of conveniences and services...

Bloomfield COUNTRY MANOR 334-6236 FARMINGTON HILLS Just completed, one bedroom apartment. Central air, appliances, carpeting, drapes...

CHURCHILL SQUARE APPTS. TROY'S finest 1 bedroom apartment includes dishwasher, carpeting, full size washer and dryer in each apartment...

Winkleman REAL ESTATE 649-3510 BY owner Rochester area 3 bedroom ranch 2 1/2 car attached garage, new carpeting, tastefully decorated thru-out, reduced for quick sale \$29,900 Call for app. Buyers only 652-4638

WALLED LAKE Dandy modern 3 bedroom aluminum ranch, large lot, full price only \$19,000, with \$2000 down 349-8700 BRUCE ROY REALTY INC.

NOVI Old Orchard, 7 1/4% assumable, 3 bedroom, family room, 1 1/2 baths, fenced patio, \$38,900 year around around pool...

SMILE We have listings on numerous SINGLE and DOUBLE WIDE MOBILE HOMES in Ypsilanti, Belleville, Plymouth, and Wixom...

342 Lakefront Property WEST BLOOMFIELD Middle Straits Lake Privileges Almost new 3 bedroom ranch with 1 1/2 baths, carpeting, thermo windows...

356 Investment Property For sale FORMER Michigan resident has interest in local limited partnership for sale also attractive Arizona investment land with low down payment & tax shelter...

WALDEN WOOD IN SOUTHFIELD Extra Spacious 1 & 2 Bedroom Apartments. Townhouses RENT from \$290 Month Offering a complete complement of conveniences and services...

Bloomfield COUNTRY MANOR 334-6236 FARMINGTON HILLS Just completed, one bedroom apartment. Central air, appliances, carpeting, drapes...

CHURCHILL SQUARE APPTS. TROY'S finest 1 bedroom apartment includes dishwasher, carpeting, full size washer and dryer in each apartment...

Winkleman REAL ESTATE 649-3510 BY owner Rochester area 3 bedroom ranch 2 1/2 car attached garage, new carpeting, tastefully decorated thru-out, reduced for quick sale \$29,900 Call for app. Buyers only 652-4638

WALLED LAKE Dandy modern 3 bedroom aluminum ranch, large lot, full price only \$19,000, with \$2000 down 349-8700 BRUCE ROY REALTY INC.

NOVI Old Orchard, 7 1/4% assumable, 3 bedroom, family room, 1 1/2 baths, fenced patio, \$38,900 year around around pool...

SMILE We have listings on numerous SINGLE and DOUBLE WIDE MOBILE HOMES in Ypsilanti, Belleville, Plymouth, and Wixom...

342 Lakefront Property WEST BLOOMFIELD Middle Straits Lake Privileges Almost new 3 bedroom ranch with 1 1/2 baths, carpeting, thermo windows...

356 Investment Property For sale FORMER Michigan resident has interest in local limited partnership for sale also attractive Arizona investment land with low down payment & tax shelter...

WALDEN WOOD IN SOUTHFIELD Extra Spacious 1 & 2 Bedroom Apartments. Townhouses RENT from \$290 Month Offering a complete complement of conveniences and services...

Bloomfield COUNTRY MANOR 334-6236 FARMINGTON HILLS Just completed, one bedroom apartment. Central air, appliances, carpeting, drapes...

CHURCHILL SQUARE APPTS. TROY'S finest 1 bedroom apartment includes dishwasher, carpeting, full size washer and dryer in each apartment...

Winkleman REAL ESTATE 649-3510 BY owner Rochester area 3 bedroom ranch 2 1/2 car attached garage, new carpeting, tastefully decorated thru-out, reduced for quick sale \$29,900 Call for app. Buyers only 652-4638

WALLED LAKE Dandy modern 3 bedroom aluminum ranch, large lot, full price only \$19,000, with \$2000 down 349-8700 BRUCE ROY REALTY INC.

NOVI Old Orchard, 7 1/4% assumable, 3 bedroom, family room, 1 1/2 baths, fenced patio, \$38,900 year around around pool...

SMILE We have listings on numerous SINGLE and DOUBLE WIDE MOBILE HOMES in Ypsilanti, Belleville, Plymouth, and Wixom...

342 Lakefront Property WEST BLOOMFIELD Middle Straits Lake Privileges Almost new 3 bedroom ranch with 1 1/2 baths, carpeting, thermo windows...

356 Investment Property For sale FORMER Michigan resident has interest in local limited partnership for sale also attractive Arizona investment land with low down payment & tax shelter...

WALDEN WOOD IN SOUTHFIELD Extra Spacious 1 & 2 Bedroom Apartments. Townhouses RENT from \$290 Month Offering a complete complement of conveniences and services...

Bloomfield COUNTRY MANOR 334-6236 FARMINGTON HILLS Just completed, one bedroom apartment. Central air, appliances, carpeting, drapes...

CHURCHILL SQUARE APPTS. TROY'S finest 1 bedroom apartment includes dishwasher, carpeting, full size washer and dryer in each apartment...

PRE GRAND OPENING BEFORE YOU LEASE... CasLake Spore Club... 1 AND 2 BEDROOM APARTMENTS WITH 1 1/2 BATHS IMMEDIATE OCCUPANCY CHILDREN WELCOME

1975 apartments at 1965 prices... Brand new, spacious apartments in Metro Detroit's most convenient and safe location... Immediate Occupancy

Deer Creek Park Apartments Are Renting For 1969 Prices! Our Rates have been reduced Across the Board!

Deer Creek Park Apartments... Joy Rd. 2 1/2 Miles West of Wayne Rd., Plymouth... 455-2424

BROOKDALE

**400 Apartments to rent**

**LIVONIA**  
Select 1 and 2 bedroom models now available at FRANKLIN SQUARE APARTMENTS from \$290. Come see the deluxe features you can enjoy or call us at 427-6970. Model hours Sat. 9 AM to 3 PM. Sunday 1 PM to 5 PM. Evening showings by appointment only till 8 PM.

**FRANKLIN SQUARE APTS.**  
2894 Lancaster, Livonia  
1 block E. of Middlebelt Rd. off 3 Mile.

**AAA APARTMENTS, BRAND NEW 12 BEDROOMS, LARGE ROOMS.**

**FREE MONTH**  
CARPETED, AIR, UTILITIES BUT ELECTRIC. 4 MINUTES FROM 175 SYCAMORE GLADE. Manager 335-1277, 334-6306, 557-0770, 333-4738.

**MODERN DELUXE APARTMENTS**  
1-2 bedroom units. Air conditioned, carpeted, some basements, carpets, pool. W. Outer Dr. Schoolcraft area. 533-5213, 531-1502, 557-0770.

**400 Apartments to rent**

**ONE BEDROOM** apartment, all utilities except electricity. 3 blocks East of Telegraph on 7 Mile. 533-4676.

**KENSINGTON Park apartments, 1 and 2 bedroom apartments from \$175. Carpet and drapes. 437-2520.**

**PLYMOUTH HERITAGE APARTMENTS**

**N. Territorial Rd. & Sheldon (Behind NBD Bank)**

One bedroom. Carpeting and drapes in living room, large closets, air conditioning, appliances. Storage area in basement including washers and dryers. Pool. Ample parking, spacious grounds. 1 year lease. \$200 security deposit. From \$175. Adults. No pets. See resident manager or call 455-2143.

**SIX MONTH Lease** Northwest Detroit area. 1 bedroom apartment with appliances including all utilities except electricity. \$155. Call after 2 PM. Agent. 533-4600.

**WESTLAND Woods apartments**  
One and two bedroom apartments, carpeted, air conditioned, swimming pool. Adults. 6031 Wildwood 728-2380.

**400 Apartments to rent**

**Glen Cove Apartments**  
New 1 and 2 bedroom apartments from \$180. Carpet, drapes, appliances, alarm. Telegraph between Schoolcraft and Plymouth. 533-9146.

**RETIRED people welcome, 1 and 2 bedrooms from \$180. Carpet and drapes. 533-9146.**

**LIVE ON THE PARK PLYMOUTH PARK APARTMENTS**

One bedroom, carpeted living room and hall, central air conditioning, parking, pool. Ready for occupancy. \$179 month. See Manager at 40285 Plymouth Rd., Plymouth Twp. 455-4721 - 278-8319.

**Plymouth Hills Apt.**  
City of Plymouth, 764 S. Mill near Ann Arbor Trail. New 1 & 2 bedroom from \$175 including washer, dryer, refrigerator, electric range, carpet, air conditioning. No pets. Open Sat & Sun. 12 to 7. 455-4721 - 278-8319.

**400 Apartments to rent**

**IN ROCHESTER, 2 bedroom lowhouses and apartments available immediately. From \$219 per month. Call Rochester Park Apartments collect. 1-451-9751.**

**HINES PARK APTS. WESTLAND 1 and 2 BEDROOMS FROM \$190**

Carpeting, dishwasher, air conditioning, security intercom. 2 swimming pools and glamorous clubhouse.

Overlooking beautiful Hines Park with its fabulous recreational facilities, nature trails and picnic areas. Public transportation at entrance. Only 5 minutes East of Hudson's Westland Center.

**SORRY, NO PETS**

**COWAN ROAD, Just North of Warren. 1 block West of Merriman. 425-0052**  
Monday-Friday 11-6  
Saturday-Sunday 12-5

**400 Apartments to rent**

**WESTLAND ESTATES & WAYNEWOOD APTS.**  
Feature  
1 and 2 bedrooms: \$190 and up. Carpeting, drapes, appliances, air conditioner. Infants welcome. No pets. Call 9:30 - 6. Monday - Friday.

**PLUS Pool & Clubhouse**  
6843 N. Wayne Rd. Westland Between Ford & Warren Rd. 721-3600

**GLENS OF BLOOMFIELD**  
Luxurious 3 bedroom apartments & townhouses with garages. 14 Mile and Telegraph. 643-4220.

**NOW RENTING Plymouth House Apts.** Spacious 1 & 2 bedroom apts. Quiet Residential setting. Heat included. Pool & air conditioning. From \$175 per month. Call Mgr. Daily 10 AM - 6 PM, Sun. 2-6 PM. 455-2753.

**402 Furnished Apts. For Rent**

**FURNISHED EFFICIENCY apartment with garage near downtown Plymouth. \$45 per week, or \$180 per month. Includes all utilities, \$100 security deposit. 453-4492.**

**402 Furnished Apts. For Rent**

**FURNISHED EFFICIENCY APTS.**

being built and available May 1st. Central heating and air conditioning, disposal, electric stove & 2 door 12 cubic ft refrigerator, separate laundry and storage facilities, soundproof and security systems. 620 South Center, downtown Royal Oak. \$200 per month. Applicants must be over 24 years old and have income of not less than \$19,900 per year. Applications now being taken.  
CALL MIKE LAURENCELLE 549-8320

**RETIRED couple preferred Two bedroom Condominium for summer, \$175 plus utilities, near Woodward. No pets. 421-2073**

**MONTHLY LEASES COMPLETELY FURNISHED**

Lovely 1 & 2 bedroom apartments. Linens, dishes, TV, air. Excellent location. From \$395.

**ROYAL CHAMBERS APTS 334-1502**

**402 Furnished Apts. For Rent**

**FURNISHED 2 room apartment, utilities included. Deposit. Call before, 5 PM. 455-2817**

**404 Houses to rent**

**12 VACANCIES**  
See 413. Rental Agencies Tip Top Guide 835-3240

**GRAND RIVER-GRAYFIELD area, 4 bedrooms, 2 baths, \$300 plus security. 427-3322**

**LIVONIA, 2 bedroom, available May 1st, \$210. After 4 PM. 421-1457**

**WEST BLOOMFIELD, tri-level, 3 bedrooms, family room, basement, fireplace, BBQ, all kitchen appliances, freezer, beautiful country setting, lake privileges, \$400 month. 548-7368, 342-4444**

**FIVE MILE TELEGRAPH** Rear house, 1 bedroom, carpet, stove, refrigerator, gas heat, single, retiree or newlyweds, \$155. Security. KE 8-3055

**LIVONIA, 7 Mile & Farmington area TWO bedroom, large lot, garage, fireplace, \$195 per month. Security deposit. 559-3650**

**LIVONIA, 3 bedrooms, 1 bath, garage, 1 1/2 acres, dead end street. Ideal for children. \$275 per month. Available July 1, 1975. After 6 PM. 645-2384**

**404 Houses to rent**

**PLEASANT small 1 floor 2 bedroom house, Carpeting, curtains, appliances including washer & dryer. 13 Mile & Coolidge area. \$186. Call between 8 AM-4 PM, M-F 7-1400 Evenings. 628-7621**

**LARGE FARM house, inquire at 8000 Newburgh Rd., Westland \$235 monthly, security. 647-7559**

**TROY, 2 bedroom ranch with 3 acre orchard. Family room, basement, 2 car garage. 1.75 and Big Beaver. \$400. 647-7559**

**HOW TO RENT YOUR HOME & STILL HAVE PEACE OF MIND**

We offer a unique TOTAL property management service which includes securing qualified tenants, proper scheduling and collection of rents, complete accounting and surveillance of the premises.

643-0100

**Cranbrook**  
Assoc. Inc. Realtors

**412 Townhouses- Condos To Rent**

**NORTHFIELD HILLS, 3 bedroom, den, 2 1/2 baths, garage, central air, carpets, clubhouse, pool. After 5 PM. 628-0686**

**SENIOR CITIZENS SPECIAL**  
Beautiful 1-2 1/2 Bedroom AS LOW AS

**\$42 PER MONTH**

**YOUR RENT INCLUDES**

- Gas heat & hot water
- Gas oven & range
- 2 dr. refrigerator
- Garbage disposal
- Fully carpeted
- Clubhouse
- Plus many other Luxuries features
- No. Waiting

**EUREKA TOWNHOUSES**  
On Eureka Road West of Telegraph 941-5235  
OPEN DAILY & SUNDAY 9-8 PM  
An Equal Housing Opportunity

**SPACIOUS condominium in Farmington Hills, located in the 12 Mile Orchard Lake area. Complete with 2 large bedrooms, recreation area, utility room, living room, dining nook, kitchen and fully enclosed garage. Never occupied. Buyer transferred out of state and committed to 1 year lease. Sub-tenant will assume reduced rate as seller will subsidize portion of payment. Call Mon. - Fri. 8:30 AM - 5 PM. Fred Gazaley or Jane Stacy 531-9300**

**NEAR B'HAM SHOPPING NEWLY DECORATED 3 Bed room, bath and 1/2 basement and garage \$375 monthly. Can be furnished for additional rent. 644-0150. Eves 642-5517**

**TOWNHOUSE APARTMENT**  
Attractive 2 bedroom, 1 1/2 baths, full basement, central heat and air conditioning, carpet, drapes and utilities included. \$275 per month.  
**RIVER BEND APARTMENTS**  
30500 W. Warren 421-4977 Bet. 11-7

**TROY, 3 bedroom, 1 1/2 baths, all appliances, drapes, air conditioning, Pool, tennis. Near lake and playground \$395. 641-9111**

**MOON LAKE RENTAL TOWNHOUSES ON PRIVATE LAKE IN WEST BLOOMFIELD**

- Birmingham Hills Schools
- Golf course, tennis courts, fishing
- Clubhouse & swimming pool
- Wine cellar, bar greenhouses
- Attached garage with opener
- Quiet with no common walls

From \$425.  
On Long Lake Rd. 1 Mile W. of Middlebelt 626-4888

**BIRMINGHAM**  
Eton Square corner of Villa. Eton 2 blocks S. of Maple across from Birmingham commuter depot. Luxury 3 Bedroom Townhouse \$340 Month  
2 1/2 baths fully carpeted, central air, Dishwasher, full basement, large private patio. Mon-Fri. 9 AM-5 PM. 644-1300

# HOME, SWEET HOME

## NOW-OR LATER?

**THE BIG GAMBLE.** "If I postpone buying a house, will I save money?" That's the big question asked by house hungry folks these days who want to keep an eye on their money. And the advice they're getting may not always be the best. If you've been advised to wait for housing costs to drop and interest rates to relax, it's a gamble, and the odds are against you. Prices of homes go up every year, an average of 6%—and that's a conservative estimate. And only a spectacular drop in interest rates could really effect a savings for you. That's because it takes an interest rate drop of 2% to equal the 6% annual increase on a \$50,000 home. And the costs of land, labor and building materials are likely to continue increasing. All of which means, if you're looking for a home and you wait to buy it, you'll end up paying interest on a lot more money for the same amount of house.

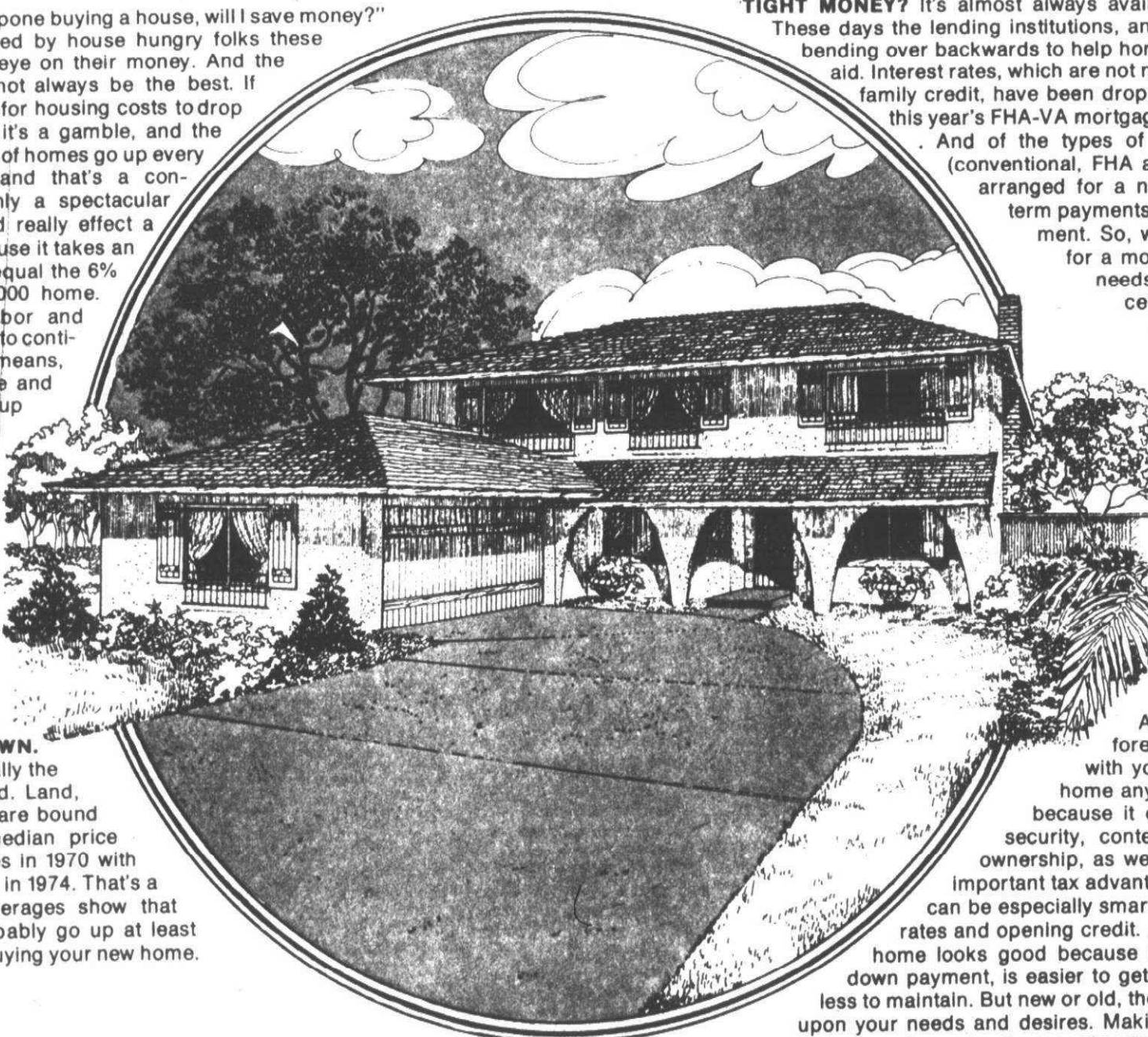

**COSTS CAN'T COME DOWN.** It's a familiar story. Historically the cost trend is always upward. Land, materials and construction are bound to follow. Compare the median price (\$23,030) for existing homes in 1970 with the median price of \$32,040 in 1974. That's a 39% increase. National averages show that construction costs will probably go up at least 15% each year you put off buying your new home.

**BUT THERE IS A BRIGHT SIDE.** Compared with expenditures on many items, homes offer very good value for the money. And experts agree that a good home is your best hedge against inflation these days because it increases in value an average of 6% a year. So, though the dollar becomes "cheaper," your home value zooms and your payments remain the same. To continue to wait (pay rent) in the hopes of buying a home for less in the future appears the expensive way to cope with today's inflation.

**TIGHT MONEY?** It's almost always available for good mortgages. These days the lending institutions, and the government too, are bending over backwards to help home buyers obtain mortgage aid. Interest rates, which are not nearly as high as most other family credit, have been dropping a little, as reflected in this year's FHA-VA mortgage interest cut from 9 to 8 1/2%. And of the types of mortgage loans available (conventional, FHA and VA), almost all can be arranged for a new home with easy, long-term payments and a moderate down payment. So, while it's important to shop for a mortgage that best suits your needs, you can obtain some excellent financial packages now at rates that may never be available to you again.

**ENJOYMENT NOW**  
Almost everyone wants a place to call their own. Whatever your reasons for wanting to buy, the one at the top of the list is probably your family. That's because where you live affects the quality of your life, and buying a home represents a better way of life for most. And now more than ever before, you need to feel happy with your surroundings. Buying a home any day can be a smart move because it offers a lot of advantages: security, contentment, privacy, pride of ownership, as well as increasing equity and important tax advantages. Buying a home today can be especially smart in view of lowered interest rates and opening credit. Practically speaking, a new home looks good because it usually requires a lower down payment, is easier to get a mortgage for, and costs less to maintain. But new or old, the choice of a home depends upon your needs and desires. Making that choice now means that you and your family can enjoy now.

**THE FUTURE.** Homes today look good in terms of the future. Home modules and lots in the decades ahead will probably be much smaller, while the possibility of materials shortages continues to loom. And as price tags everywhere carry higher figures, so will the ones on homes. Taking value appreciation, costs and equity into consideration, buying a home today looks like a good idea.

**A CREATIVE LOT.** Whatever your reasons for buying a home, you want to find the best one for your needs, wants and means: a place that "works" for you and your family. Realtors can be a creative lot when it comes to helping you make that choice. They're professionals who can offer you up-to-the-minute counsel on home values and financing opportunities...counsel which can prove invaluable to you in these confusing economic times. Local realtors are great to use as guides when you're hunting for a home, and can definitely make the home buying process simpler and more pleasant for you.

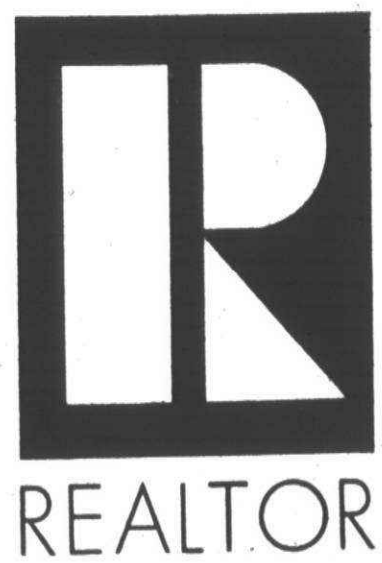

THIS MESSAGE WAS SPONSORED IN THE PUBLIC INTEREST BY: THE OBSERVER & ECCENTRIC NEWSPAPERS

**406 Furnished houses To Rent**

**BEVERLY HILLS, furnished 2 bedroom, fireplace, shag carpeting, fenced yard, garage. \$200 month, security deposit. 16236 Kirkshire, 852-2400**

**FARMINGTON HILLS, beautifully furnished 3 bedroom executive ranch, 2 1/2 baths, family room with fireplace, attached 2 1/2 garage with opener, central air with electronic filter. No children, no pets. 1 year lease. \$650 per month. 1st and last month and 2 month security deposit. References Available July 1, 1975. 851-4282**

**GARDEN CITY, 2 bedroom, \$235 month. \$235 security deposit. Single girls or married couples only. No pets or children. 425-9524**

**BEVERLY HILLS, Furnished 1 1/2 bedrooms, fireplace, fenced yard, shag carpet, 16236 Kirkshire, \$290 month, \$200 security deposit. 642-2481**

**408 Duplexes to rent**

**12 VACANCIES**  
See 413. Rental Agencies Tip Top Guide 835-3240

**410 Flats to rent**

**12 VACANCIES**  
See 413. Rental Agencies Tip Top Guide 835-3240

**BIRMINGHAM 2 bedroom lower flat, carpeting throughout, living room, dining room, large kitchen, garage, private basement, heat included. \$225. 626-1069**

**412 Townhouses- Condos To Rent**

**12 MILE, DEQUINDRE, 2 bed room condo, fully carpeted, \$275 month not including electric, \$500 security deposit. 368-3088 or 778-0906. 835-3240**

**LUXURY completely furnished condo, June through August, 3 bedroom, 2 1/2 baths, pool, tennis courts, sauna, Northfield Hills, Troy. 641-8171**

**SOUTHLAND TOWNHOUSES FOR FINE WORKING PEOPLE WITH MODEST INCOMES**  
Beautiful 1 1/2 Bedrooms RENT AS LOW AS

**\$140 PER MONTH**

**YOUR RENT INCLUDES**

- Gas heat & hot water
- Gas oven & range
- Refrigerator freezer
- Garbage disposal
- Fully carpeted
- Community building
- Plus many other Luxury Features
- No. waiting!

**ON EUREKA ROAD**  
West of Telegraph 941-3556  
OPEN DAILY 10-8 PM  
An Equal Housing Opportunity

**TWO bedrooms, appliances, air, basement carpeted, draperies. Pool, club house. Gas, water paid \$325. Plus security. Year lease. 846-8482**

**414 Florida Rentals**

**GULF FRONT condo, Sarasota area. Furnished, includes linens. 2 bedrooms, 2 baths, sleeps 6. Tennis courts, swimming pool. 882-6196**

**400 Apartments to rent**

**SOUTHLAND APARTMENTS**  
Huge 1, 2, & 3 Bedrooms, now available  
From \$150 monthly  
Modest monthly rent includes:

- Gas heat
- Completely carpeted
- Garbage disposal
- Gas oven and range
- 2 door refrigerator-freezer
- Large walk-in closets
- Community activities building

**NEW MODELS (Open 10-8 Daily)**  
are located on Eureka Rd. between Telegraph and Beech Daly in Taylor  
941-3556

414 Florida Rentals

HOLLYWOOD: A beautiful furnished condominium overlooking swimming pool tennis and golf course. Call 353-2040.

416 Vacation Rentals

UNION LAKE AREA: Lakeland home, calm, attractive, excellent fishing, swimming, boat included. Weekly through August. 351-0800.

DELUXE LAKE Michigan beach cottage near Glen Lake and Sleeping Bear Dunes. Electric heat, 2 fireplaces, 1 1/2 baths, etc. Available May, June through July 12 by week or weekend. 616-949-8338.

SLEEPING BEAR Dunes, Glen Arbor, Michigan on Crystal River, bedroom mobile home, completely furnished \$30 weekly. 381-3207.

AVAILABLE: July, August, comfortable 3 bedroom cottage North Shore Higgins Lake. \$200 week. 2 week minimum. Call between 7PM-9PM. 355-8871.

BOYNE COUNTRY: Two tier chalet, fully furnished. Upper: 4 bedrooms, 2 1/2 baths, kitchen, fireplace, lower: 3 bedrooms, 2 1/2 baths, kitchen, fireplace. Private connecting if desired. Private putting green, tennis, swimming, horseback riding, fishing. 425-9335.

IRISH HILLS large lake side cottage walk out basement, balcony, fireplace, close to everything. \$200 week. Box 93, Garden City, Mich. 613-55.

LAKE CHARLEVOIX lovely lakeland home completely furnished. Sandy beach. Excellent fishing, boat included. Available May 1 to June 14th. 353-5450.

TED & GERRY'S Resort, in Lewiston on Little Water Lake. Modern housekeeping cottages with bath. Enjoy swimming and fishing. \$85-\$95 per week. 422-3138.

LAKE CHARLEVOIX 2 carpeted, furnished modern lakeview cottages. Fireplace, sauna, by week. \$125-\$150. 433-5428 or 353-7272.

420 Rooms to rent

COMFORTABLE sleeping room for man or woman. 7 Mile, Farmington Rd. Livonia. 476-8655.

SLEEPING ROOM for mature gentleman. Convenient location in Plymouth. Outside entrance. 453-3745.

PLYMOUTH near town large sleeping room for mature gentleman \$22 weekly. 459-0749.

GARDEN CITY nice room house privileges for young working female. \$150 a month. \$100 security deposit. 261-7888.

EMPLOYED woman kitchen priv. 8126 Harrison Garden City. 422-0225.

JOY MIDDLEBELT Livonia. Comfortable sleeping room. Employed middle aged person. References with or without kitchen provided. After 5 PM. 506-6787.

FURNISHED ROOM with separate bathroom for rent in Cleveland close to Oakland Mall. References required. Call after 6 PM. 388-1094.

422 Commercial Industrial to rent

INDUSTRIAL BLDG. For lease or rent with Plymouth city limits. Big doors - high ceilings - well insulated and heavy floors. 455-2390.

NEW STORES

3 new stores for lease on Grand River in Farmington. Available immediately. 14 other stores already open for business in shopping center. Contact Gary Burkhardt, 476-8700.

Thompson-Brown

CITY of Plymouth industrial zoned RR siting. 2700 sq ft of warehouse space. 500 sq ft office space. Utilities included in rent. Space only \$500 per month. Available May 1st. 453-0250.

Commercial Units available in residential Apartment Complex with 478 units.

LINCOLN TOWERS

Prime location, approx 630 sq ft, ideal for professional or retail. Heat, Hot Water, Central Air. Carpeting included.

Call 968-0011

424 Office-Business Space to rent

PLYMOUTH, 2 room, 300 sq ft professional office second floor. Carpeting, drapes and utilities. \$50 per month. 453-7990.

OFFICE SPACE for rent, 2 room. 1100 sq ft. Call for location. Farmington. Excellent for accountant, manufacturer's rep or insurance. 478-1940.

SOUTHFIELD beautifully finished suites. 1900 sq ft. free basement storage, extra parking spaces. 10 Mile Rd. between John Lodge and Southfield expressways. Call Washington Square Office Center. 353-2000 or 353-0043.

Old Town Farmington

OFFICE Building, 2400 Sq Ft. Completely private atmosphere. Double entrance each with foyer. Hand carved Walnut Doors. Terraced and landscaped. Ample private parking. 4 large private offices. Very good natural lighting. Large General Office. Ample closet and storage space. Ideal for Psychiatrist - Psychologist combination. Or Law suite. 474-2814.

CHOICE office suite available in Executive Building, 890 E. Maple, Birmingham. 200 Sq Ft. Walnut paneling, new drapes. Free parking and air conditioning. 647-4287.

SOUTHFIELD beautifully finished suites. 1300, 578 sq ft. free basement storage, extra parking spaces. 10 Mile Rd. between John Lodge and Southfield expressways. Call Washington Square Office Center. 353-2000 or 353-0043.

LIVONIA - Farmington Rd. near 7 Mile. 1 mile. \$100 monthly. Everything but phone. Could be month to month. Call MRS. BARRIE. 678-1444.

Bloomfield Hills

Woodward and Square Lake Rd. area. 800 sq ft. suite ready for occupancy. Carpeting, drapes, central air and ample parking. 858-2377.

TROY - Prestigious office building. Big Beaver and I-75. 100 to 2,000 sq ft. Immediate occupancy. 382-1378.

NOVI - Grand River area. 1000 sq ft. Retail or office. 389-3422.

424 Office-Business Space to rent

GENERAL & PROFESSIONAL Office space available in beautiful modern Kimberly Oaks professional complex. Includes parking. Convenient to expressways. Reasonable rental rates. 353-2000.

\$85-EXECUSPACE IMPERIAL OFFICE PLAZA Southfield including receptionist, telephone answering, conference room, all utilities, janitorial, etc. Carpeting. Furnishing available. Secretarial available. Coffee shop on premises.

NO LONG TERM COMMITMENT NECESSARY HAYMAN MANAGEMENT CO. 353-0520 353-0525

MAPLE & Telegraph 400 sq ft. of prime office space. Carpeting, drapes, air conditioning, heat, sound and air conditioning. \$42-900.

FORD RD. Middlebelt area. 2000 sq ft. second story building, will rent on or part, ample parking, no reasonable offer refused. 422-7030.

BLOOMFIELD HILLS, available immediately. 684 sq ft. of office space, divided into 4 offices and 2 reception areas. Woodward - Long Lake Rd. For further information call Ann Arbor. 682-4518.

W. Maple & Cranbrook Rd.

RETAIL STORE FOR LEASE 20' x 73' BY KOPMAN MGT. CO. 353-1290

SOUTHFIELD Lathrup Village. 2 office suites available in small professional office building. Party furnished or unfurnished. All utilities and air conditioning included. 557-1330.

OFFICE for lease. 440 sq ft. Clearwater Life Insurance Bldg. corner Woodward - Big Beaver Rd. Carpeted, air, drapped. Free parking. 647-2133.

LIVONIA OFFICE PAVILION

INDIVIDUAL OFFICES to 2500 Sq Ft. Suites custom designed. Rentals from \$75 per month including all services, carpeting and drapes. IMMEDIATE OCCUPANCY. Call Carolyn. 548-5520

LIVONIA - Schoolcraft - Farmington Rd. Brand new office building. All services provided. Carpeted. \$150 - \$300 per ft. suites. 425-8900.

OFFICE space available, very reasonable rent. Job ready and ready to go. 459-2030.

TO BUSINESSMEN WHO MAINTAIN A GIRL OFFICE Let us solve your problems, save money and give you a private office in the most convenient, personalized secretarial services than you ever thought possible. National and local references. Write or telephone letterhead or call for illustrated brochure.

EXECUTIVE GROUP, INC. S. Adams Sq. B. Ham. 642-2022. Ex-Cell-O Bldg. Troy. 462-1580. Parklane Towers. Dearborn. 271-8500.

BIRMINGHAM furnished, suitable for manufacturer or contractor. Air conditioned parking available. \$100 month includes utilities. 642-2338.

OFFICES 14 MILE & PIERCE, Birmingham. 475, 240 and 120 sq ft. Offices, carpeting, drapes, etc. included. Will partition to suit tenants. 462-4554.

EXECUTIVE SUITES AVAILABLE

includes spacious parking facilities. First floor. Experienced Executive Secretaries, personalized phone answering, duplicating, notary. Harvard Suite, 29350 Southfield Rd. Suite 122. Southfield, Michigan. 557-2757.

DEARBORN HOT SPOT suites available. Utilities furnished. Rates below market. 557-0770. Evs. 544-4474. 353-4738.

NEW BUILDING, excellent location on Highland Rd. (M-39) near Williams Lake Rd. Air conditioned, carpeted and paneled. Lots of paved parking. Call 262-2100 or 373-1000.

426 Convalescent Nursing homes

PLYMOUTH new location Private home for elderly. Good food, friendly atmosphere. Vacation or permanent nursing care. New decorated. Clean. 459-4855.

430 Wanted to rent

LATE June, July and August. Nice 1/2 acre to share with home in Bloomfield, Birmingham, Troy, or Royal Oak area. Retired Arizona couple, former GM executive and Bloomfield Hills resident. Best of local personal and financial references. Give details to Box 640, Observer & Eccentric Newspapers, 36251 Schoolcraft, Livonia, Michigan 48150.

FURNISHED 1 bedroom apartment for 2 or 3 months in summer. W. Bloomfield, Bloomfield, Birmingham or Southfield area. 851-2037.

NEED home in Plymouth or Canton area to rent while awaiting new home. Maximum 3 months. Family of 4. References. 455-7737.

TWO responsible females, college students, need house to rent during summer months. Plymouth area. 458-9238 or LO-5771.

RETIREE Couple from Naples, Florida would like to rent 1 or 2 bedroom apartment mid July thru mid October. Excellent local references. 647-1653.

WANTED to rent: garage space for small European car. Prefer Southfield area, between Greenfield and Telegraph, North of 9 Mile. Call weekdays, 9 AM-5 PM. 253-2377.

4 BEDROOM, Birmingham, Derby School area, need occupancy by June 30, 1975. After 6 PM. 645-2384.

ROOM wanted, in home on Lake St. in professional Lady P.O. Box 516, Birmingham, MI. 48012.

432 Living Quarters To share

CLEAN, responsible, working person to share my home with me and other bachelor in 7 Mile. 1100 monthly plus utilities. \$100 security. Furniture not necessary. Call 353-2000 or 353-0043.

WANTED to rent: garage space for small European car. Prefer Southfield area, between Greenfield and Telegraph, North of 9 Mile. Call weekdays, 9 AM-5 PM. 253-2377.

4 BEDROOM, Birmingham, Derby School area, need occupancy by June 30, 1975. After 6 PM. 645-2384.

ROOM wanted, in home on Lake St. in professional Lady P.O. Box 516, Birmingham, MI. 48012.

432 Living Quarters To share

CLEAN, responsible, working person to share my home with me and other bachelor in 7 Mile. 1100 monthly plus utilities. \$100 security. Furniture not necessary. Call 353-2000 or 353-0043.

WANTED to rent: garage space for small European car. Prefer Southfield area, between Greenfield and Telegraph, North of 9 Mile. Call weekdays, 9 AM-5 PM. 253-2377.

4 BEDROOM, Birmingham, Derby School area, need occupancy by June 30, 1975. After 6 PM. 645-2384.

ROOM wanted, in home on Lake St. in professional Lady P.O. Box 516, Birmingham, MI. 48012.

WANTED to rent: garage space for small European car. Prefer Southfield area, between Greenfield and Telegraph, North of 9 Mile. Call weekdays, 9 AM-5 PM. 253-2377.

4 BEDROOM, Birmingham, Derby School area, need occupancy by June 30, 1975. After 6 PM. 645-2384.

ROOM wanted, in home on Lake St. in professional Lady P.O. Box 516, Birmingham, MI. 48012.

432 Living Quarters To share

ROOMATE Wanted. Somerset Park Apartments. Call Mike between 6 and 8 PM. 643-0524.

MIDDLE AGED woman with 11 year old son will share home with same. Westland. \$130 monthly. Utilities included. 522-7279.

EXECUTIVE, 24, wishes to share his apartment with a responsible person only. Call Mr. Douglas after 9:30 PM. 354-1124.

TOWNHOUSE to share in Birmingham, \$120 a month, many extras. Call anytime. 642-2220.

436 House Siting Services

WE are a young, married couple (late 20's), teachers, who desire house - sitting situation for modest rental in Western Michigan during summer. Very reliable, references available. Contact Thomas Glaser, 77 Dexter Park, Cambridge, Mass. 02140.

HOUSE SITTING PLANT WATERING EXECUTIVE sits with dogs, fish, cats. House Siting since March. Available April 28 through June. Excellent References. Call John Reddy, Weekdays. 641-1100.

500 Help wanted

DRUG store clerks, fully experienced in various departments, full or part-time. Southfield. W. Bloomfield stores. Efron Drugs, 6127 Orchard Lake Rd. W. Bloomfield.

TEACHERS - begin developing your own profitable business now. Expand to full-time in summer. No monetary investment. For appointment. 664-3880.

MAINTENANCE Man, experienced in electrical welding and pipe fitting. Call between 3PM - 4PM only. 346-1135.

Manager Trainee Expanding sales office needs young men to help in our progress. No layoffs. \$800 per month guarantee available to qualified applicants. Must be neat, dependable and want a career. For further information call Tuesday only 10 to 6 PM. 425-8888.

BEAUTICIAN, experienced with clientele for new shop in NW 24th & von. 478-2451.

VACUUM CLEANER SERVICE Seeking enthusiastic person with mechanical experience for Southfield area. Full time position. 558-2012 or 358-4871.

CLAIMS PROCESSOR trainee, dental experience. \$120 week. Towne Personnel West. 274-2250.

CASH CLERK - Bank or super-market experience. \$150 per week. Towne Personnel West. 274-2250.

CLAIMS PROCESSOR trainee, dental experience. \$120 plus week. Towne Personnel West. 274-2250.

IMMEDIATE OPENINGS

MANAGEMENT TRAINEE Men and women to start work immediately. No experience necessary. \$800 month to start if you qualify. W. A. Home Investment Co. 547-2376.

BEAUTY OPERATOR, full-time, clientele waiting. Sean's Hair Fashions, Auburn Hills. 852-1441. Evenings. 852-3842.

DELIVERY Sunday work, 6 to 7 hours. Call in basis for weekdays. Company car. Must be 21 and over. Good driving record. Ideal for retiree. 642-2338.

OFFICES 14 MILE & PIERCE, Birmingham. 475, 240 and 120 sq ft. Offices, carpeting, drapes, etc. included. Will partition to suit tenants. 462-4554.

EXECUTIVE SUITES AVAILABLE

includes spacious parking facilities. First floor. Experienced Executive Secretaries, personalized phone answering, duplicating, notary. Harvard Suite, 29350 Southfield Rd. Suite 122. Southfield, Michigan. 557-2757.

DEARBORN HOT SPOT suites available. Utilities furnished. Rates below market. 557-0770. Evs. 544-4474. 353-4738.

NEW BUILDING, excellent location on Highland Rd. (M-39) near Williams Lake Rd. Air conditioned, carpeted and paneled. Lots of paved parking. Call 262-2100 or 373-1000.

426 Convalescent Nursing homes

PLYMOUTH new location Private home for elderly. Good food, friendly atmosphere. Vacation or permanent nursing care. New decorated. Clean. 459-4855.

430 Wanted to rent

LATE June, July and August. Nice 1/2 acre to share with home in Bloomfield, Birmingham, Troy, or Royal Oak area. Retired Arizona couple, former GM executive and Bloomfield Hills resident. Best of local personal and financial references. Give details to Box 640, Observer & Eccentric Newspapers, 36251 Schoolcraft, Livonia, Michigan 48150.

FURNISHED 1 bedroom apartment for 2 or 3 months in summer. W. Bloomfield, Bloomfield, Birmingham or Southfield area. 851-2037.

NEED home in Plymouth or Canton area to rent while awaiting new home. Maximum 3 months. Family of 4. References. 455-7737.

TWO responsible females, college students, need house to rent during summer months. Plymouth area. 458-9238 or LO-5771.

RETIREE Couple from Naples, Florida would like to rent 1 or 2 bedroom apartment mid July thru mid October. Excellent local references. 647-1653.

WANTED to rent: garage space for small European car. Prefer Southfield area, between Greenfield and Telegraph, North of 9 Mile. Call weekdays, 9 AM-5 PM. 253-2377.

4 BEDROOM, Birmingham, Derby School area, need occupancy by June 30, 1975. After 6 PM. 645-2384.

ROOM wanted, in home on Lake St. in professional Lady P.O. Box 516, Birmingham, MI. 48012.

432 Living Quarters To share

CLEAN, responsible, working person to share my home with me and other bachelor in 7 Mile. 1100 monthly plus utilities. \$100 security. Furniture not necessary. Call 353-2000 or 353-0043.

WANTED to rent: garage space for small European car. Prefer Southfield area, between Greenfield and Telegraph, North of 9 Mile. Call weekdays, 9 AM-5 PM. 253-2377.

4 BEDROOM, Birmingham, Derby School area, need occupancy by June 30, 1975. After 6 PM. 645-2384.

ROOM wanted, in home on Lake St. in professional Lady P.O. Box 516, Birmingham, MI. 48012.

WANTED to rent: garage space for small European car. Prefer Southfield area, between Greenfield and Telegraph, North of 9 Mile. Call weekdays, 9 AM-5 PM. 253-2377.

4 BEDROOM, Birmingham, Derby School area, need occupancy by June 30, 1975. After 6 PM. 645-2384.

ROOM wanted, in home on Lake St. in professional Lady P.O. Box 516, Birmingham, MI. 48012.

500 Help Wanted

PART-TIME Typing and General office duties. Experience preferred. Call Mrs. Sullivan. 281-9550.

SHAMPOO Girl Assistant, licensed, apply in person only. Nicholas Intercollegiate, 1991 Northwestern Hwy., Southfield.

HAIRDRESSER wanted, some clientele preferred. Apply in person only. Nicholas Intercollegiate, 1991 Northwestern Hwy., Southfield.

INSURANCE TRAINEE Business office plus light sales. Career oriented. N.W. area. Zaida. 556-4760.

KAY TURNER PERSONNEL 18280 W. 10 Mile Rd. SOUTHFIELD

HOUSEKEEPER Woman to live-in and care for 2 young children, ages 5 and 7. Room and board, private phone, in very nice home in Westland. Position is immediately open and permanent. 352-3100 ext. 267.

MACHINIST Mill & lathe hand, must have 5 years experience. Apply in person. Jorgensen Tool & Gauge, 3210 W. 8 Mile Rd. Farmington. 478-0357.

PLYMOUTH area insurance agency desires recent college graduate in business administration. Some basic insurance and EDP knowledge desirable. Ability to organize and execute departmental responsibilities. Call Maureen. 455-6000. An Equal Opportunity Employer.

EMPLOYMENT COUNSELOR Agency experience preferred. 6 Mile, Telegraph area. Call N. Hanley. 258-7400.

ATTENTION MALE MODELS! Position in Handy Person Employment Center. 358-8550.

EMPLOYMENT COUNSELOR Troy office of nation's largest employment office. We will train you. Management opportunity plus full benefits. Call Ms. Schreiber. 588-5400.

COOK 2 yrs. Experience. Northland Area. Employment Center. 358-8550.

MAINTENANCE MAN \$150 WEEK Must be Experienced. Employment Center. 358-8550.

TV Service Men Experienced road man and experienced shop men for well established service shop. See Dave Foster at: Berry's Home Supply 27419 Joy Rd. Westland. 421-1438 or 937-0727.

ASSISTANT MANAGER For automotive car wash with gasoline. Must be 30 years old. Nice opportunity for the right man. 455-1011.

SPRINKLER INSTALLERS, experience preferred but not necessary. 427-1170.

SPORTS OFFICIALS Need experienced baseball and softball umpires. \$4 - \$9 Per Game (Non-residents may apply). Apply immediately to City of Livonia Civil Service Commission, 32323 Five Mile Rd. An Equal Opportunity Employer. 453-2650.

INJECTION molding and assembly plant needs young man for assistant foreman's position. Some molding and assembly experience. Located in Oak Park. Call Mr. Abele. 398-4300.

TELEPHONE WORK No soliciting. Mature intelligent person over 28. Enroll our students and deal with our instructors over the phone. Immediate permanent openings. Hourly rate plus incentive bonus, company paid fringe benefits. Training provided. Apply after 12 Noon, 23381 Telegraph, near 7 Mile. 477-7400.

COMPUTER Operator, with experience on any Disc System. To work on computer systems. Located in Oak Park. Call Mr. Abele. 398-4300.

UTILITY MAN for Dietary Dept. Good wages and benefits. GREAT BOSS! Apply Mrs. H. Monday through Friday, 8 AM to 4 PM. FARMINGTON NURSING HOME 30405 Folsom Rd. Farm. 477-7400.

COMPUTER Operator, with experience on any Disc System. To work on computer systems. Located in Oak Park. Call Mr. Abele. 398-4300.

TELEPHONE WORK No soliciting. Mature intelligent person over 28. Enroll our students and deal with our instructors over the phone. Immediate permanent openings. Hourly rate plus incentive bonus, company paid fringe benefits. Training provided. Apply after 12 Noon, 23381 Telegraph, near 7 Mile. 477-7400.

UTILITY MAN for Dietary Dept. Good wages and benefits. GREAT BOSS! Apply Mrs. H. Monday through Friday, 8 AM to 4 PM. FARMINGTON NURSING HOME 30405 Folsom Rd. Farm. 477-7400.

NEED A JOB. \$5.75 per hour, or profit sharing program. Driver delivery of small home appliance. Must have auto. Call Mr. Dillard. Monday only 10 to 8 PM. 682-7207.

MARRIED women earn an average of \$3 per hour, 3 days, 3 hrs. a day. Call for personal interview. 531-2109.

PARK SUPERVISOR Must be Livonia resident with Bachelor's Degree in Social Work or related fields. Apply by Friday April 25th to: City of Livonia, Civil Service Commission, 32333 Five Mile Rd. An Equal Opportunity Employer.

HOBBY STORE Full and part time. Must have retail and hobby experience. Immediate openings. Apply to Family Hobby Center, 4400 N. Woodward, Royal Oak.

BREAKFAST COOK, experience necessary. Apply in person. Holiday Inn of Farmington, 38123 W. 10 Mile Rd. 358-0010.

DENTAL ASSISTANT wanted for busy office. Must be alert, neat, pleasant personality. Experience necessary. Madison Heights area. Schoolcraft, Livonia 48150. 398-5226.

MEDICAL RECEPTIONIST, business office experience preferred. Apply 11 AM to 5 PM. 8001 Merriman, Westland.

RN's & LPN's Full or Part-Time. Apply in Farmington. 43825 Michigan Ave.

DION NURSING HOME 43825 Michigan Ave.

MEDICAL ASSISTANT, experienced in medical techniques. Apply 11 AM to 5 PM. 8001 Merriman, Westland.

MEDICAL RECEPTIONIST, full time. Livonia. Experience preferred. Send resume to Box 704, The Observer & Eccentric, 36251 Schoolcraft, Livonia 48150.

DENTAL TECHNICIAN for Crown & Bridge Lab in Southfield. Waters, ceramists and Inlay. Experience only. Immediate openings. 357-1820.

504 Help Wanted Office-Clerical

GENERAL OFFICE WORK FORD MEDICAL LAB

504 Help Wanted Office-Clerical

Keypunch Trainee Good opportunity for recent Keypunch School Graduate. Full-time days, Nov. area. Call Miss Harrier, weekdays, between 9 AM & 4 PM at 349-5000

MATURE WOMAN with general office experience to work at Troy apartment development as assistant to manager. (Need not live on premises). Duties include light typing, bookkeeping and office procedures; management functions and rental techniques will be taught. Pleasant working conditions. Interesting diversified employment. Send brief resume and salary requirements to Box 628, Observer & Eccentric Newspapers, 26351 Schoolcraft, Livonia, Michigan 48150

TYPISTS STENOS See Maryann Burns 26049 S Mile at Beech Daly Div. Manpower Temp Services 965-7000

EXPERIENCED top notch legal secretary for senior partner in prestigious Southfield law firm. Excellent skills must include Management and Executive capabilities. Ask for Rosalie 338-6505

INTERESTED IN SELLING REAL ESTATE? Call TODAY for an interview Livonia-Farmington Tom Kuster - 476-9100 Westland-Livonia Gary Cook - 721-8400 Plymouth-Northville Vern Hackett - 455-5200 chamberlain

Need One Bright Aggressive Young Man, 23 to 30 who is not afraid of work and wants to make money. We offer a bright future for this applicant. You will be trained to sell our line of exclusive decorative fabrics and wallpaper to interior decorators and contract designers. After a reasonable training period a relocation will be necessary. Call Stanley Rubin for an appointment. B Berger Company 30100 Telegraph 647-4311

BLUE GRASS FARMS Growers of Nursery Sod. Top Soil, Landscaping, Evergreens, Seeding, Sodding, Fertilizer, Sand, Peat, Fill Dirt, Stone. COMMERCIAL & RESIDENTIAL 16185 NEWBURGH RD. 464-2080 7AM-7PM 464-2081

506 Help Wanted Sales

CENTURY 21 THINK SPRING - Think Selling Real Estate. Join the largest and still growing Real Estate Firm in the country. Offering excellent classroom training and finest referral system. Top Commission Multiple Listing Service.

BIRMINGHAM - TROY LIBBY & ASSOC. Inc. 644-3232 BLOOMFIELD-W. BLOOMFIELD SECENTINE ASSOC. 626-8800

Appliance Salesmen Two men to learn the appliance sales business. Experience helpful but not necessary. See in person Bill Scortlett. 27419 Joy Rd. Westland 421-1438 or 937-0727

AVON ADD NEW PEOPLE. NEW PLACES. NEW INTERESTS to your life. Be an AVON Representative. Excellent earnings. Call: 645-0455 427-4000 352-2926 422-2252

TELEPHONE solicitors wanted for Farmington office. Housewife's dream. Ask for Theresa Canfield, 478-1300

CAN YOU WORK WITHOUT SUPERVISION? We need man or woman to sell full line of Advertising Specialties, Calendars and Gifts in the Southfield-Birmingham area. Must be able to plan own time and work with a minimum of supervision. All accounts are protected. Repeat orders are protected. High commissions payable when orders are passed for credit.

THE DURBIN COMPANY REALTORS Bloomfield Hills Office HAS OPENINGS FOR EXPERIENCED SALESPEOPLE Who want to improve their earnings. INEXPERIENCED SALESPEOPLE Wanting a career in real estate call immediately to enroll in our training class for beginners. FOR AN INTERVIEW CALL PETE SWANNEY 647-5500

506 Help Wanted Sales

SALESPERSON, 25 years or over, experienced in women's clothing for Birmingham store. Apply in person, 2411 Fort St., Wyandotte. Experienced only need apply. Call for appointment. 285-7020

LOCAL DISTRIBUTOR needs part or full-time salesperson, calling on a variety of retail outlets, commission basis. Car necessary. Call Mon April 21, 5 PM-10 PM. 363-1239

SALESPERSON - work showroom part-time. Kitchen & bath modernization. Experience preferred. 325-0960

CONSUMER PRODUCTS SALES, \$10,000-\$12,000 Progressive national firm seeks individuals to begin as Management Trainees in Detroit and out state markets. Sales experience or a degree is essential. Actual salary background is a real plus. Market plus incentive bonus plus a company car. All fees company paid. Call Tom Wilson AMERICAN PERSONNEL AGENCY 355-5526

WANTED 4 MEN CALL - CO-1-0552 Mon., April 21 For personal interview and aptitude test. Excellent opportunity for qualified men.

REAL ESTATE Salesmen Wanted We are adding to our staff of qualified sales persons in the Birmingham - Bloomfield area. Call Alan Grossman, today, for a confidential interview. 851-4300

EXPANDING our growing business. Looking for responsible ambitious people who want additional income. Over 21 Call Mr. Rahaim, 478-1855

THE DURBIN COMPANY REALTORS Bloomfield Hills Office HAS OPENINGS FOR

EXPERIENCED SALESPEOPLE Who want to improve their earnings. INEXPERIENCED SALESPEOPLE Wanting a career in real estate call immediately to enroll in our training class for beginners. FOR AN INTERVIEW CALL PETE SWANNEY 647-5500

506 Help Wanted Sales

Real Estate Sales Earn while you learn. Business is good and we need help. Full or part time help for our new and used home division. For a confidential interview call Jerry F. Edwards, 477-4700

SALESPERSON, experienced in wallpaper and paint. Apply in person, Decor Suburban, 3504 Grand River, Farmington. 477-4700

EXPANSION Positions available for experienced or non experienced sales people. Full training facilities in classroom and in the field. Fastest growing and largest real estate firm in the country. 1000 offices nationally. Call Mr. Cheyne for appointment. 642-8100 Century 21 Libby & Assoc. South Birmingham

Telephone Sales Must be resident of Oakland County and unemployed for more than 30 days. High School education. Some sales background helpful. Complete training program. Salary, company benefits. Call Jim Riddick, 478-1656

LOCAL AMWAY Distributor offers opportunity for good earnings. Call after 3 PM. 478-1656

Are You The Person? I am looking for the person who has the desire to get into the fascinating field of cosmetics, who feels they have the ability for sales. If you are over 25 and feel you may qualify, call Mr. Barnes between 3 and 5 PM. 538-4178

507 Help Wanted Part Time RETIREE wanting to earn extra money to teach a greenhorn gardener and yard maintenance. Patient and sense of humor helpful. Will pay going price per hour. References OK. Livonia. 477-1216

NEEDED 4 women to demonstrate home decorated items. Average earnings \$10 hour. 261-0706

WANTED part-time, lady to train as school photographer. Will photograph school children within 7 mile radius of Detroit. Must have good transportation and be in good health. Work mostly September, October, and November in fall. January, February, March in spring. Send resume to box 644, Observer & Eccentric Newspapers, 36251 Schoolcraft, Livonia, Michigan 48150

WOMAN wanted as Account Representative for a local insurance agency. Selling Local travel. Lite typing. 325-8210

LUMBER Part-time counter sales, excellent opportunity. Salary plus commission. Fringe benefits. See Mr. Kolb. No phone calls please. Pine Lumber Cashway 12222 Inkster Rd. Redford Twp. 478-1139

WANTED part-time bar maid, 3 evenings weekly. For Rochester area club operation. 651-2822

STUDENT 16 or over to do odd jobs around the home in Farmington Hills. Some experience preferred and able to work weekends. 478-1139

507 Help Wanted Part Time

PART-Time counter clerks for after school & Saturdays. Good pay & all benefits. Apply Mai-Kai Cleaners, 23935 W. 9 Mile Rd. Southfield, Saturday between 1:30 & 2:30 PM. 478-6466

COOK, experienced older woman. Part time, 10 AM till 3 PM. Also cook from 5 PM till 9 PM. Apply Beau J's Lounge, 13900 Inkster Rd. 522-6060

FISHER WALLPAPER & PAINT CO. PART-TIME SALESWOMAN Mature woman who likes to meet public. Mostly evenings, approximately 25 hours. Good working conditions. WONDERLAND 425-8970

WANTED: experienced Church Organist. For particulars, call Lucille Winger at 421-5139

RELIABLE, mature woman with transportation; part time, mornings. Must be excellent, accurate typist with pleasant telephone manner. Phone after 1 PM. 945-6884

PART Time Secretary with legal experience. Mrs. Brannon, 985-7610

508 Help Wanted Domestic BABYSITTER for kindergarten boy in afternoon session. 7 Mile Middlebelt area. 477-8528

BABYSIT' in my home. Two preschool children. Own transportation. Days. 728-8688

BABY SITTER NEEDED, your home or mine, Farmington and Joy Rd. area. Call after 5 PM. 525-4593

HOUSEKEEPER wanted, 5 days live-in. Southfield area. 557-2246

BABY SITTER, mornings, Tuesday through Friday for 2 year old Pres. For Mom with toddler. Plymouth area. 455-1418

A LADY to help with handicapped school girl, hours 4-8 PM. Merriman - Avondale area. Westland 728-2565

MOTHER'S helper, child care and housework 3 children, references essential. Honest, reliable and dependable. Over 18. 1-537-3815

HOUSEKEEPER wanted, 2 days a week, must have transportation and be willing to care for one year old child. Farmington Hills area. 851-6367

BABY SITTER, experienced, needed in my home for 2 month old girl. May 12 to June 13, 7:30 AM-3:30 PM. Near Ford - Sheldon Rd Plymouth. 453-6938

MATURE, reliable cleaning woman needed 2 1/2 days. Must have references. Own transportation. Bloomfield Hills. 647-0322

RELIABLE Mature baby sitter needed 1 PM thru 8 PM, Monday through Saturday, own transportation. Livonia area, references. 325-9341

LIVE-IN, elderly lady needs care and companionship, all privileges, room, board, and salary. Southfield Call after 4 PM. 538-5290

512 Situations Wanted Female MEDICAL RECEPTIONIST, full time, experienced in front office duties, own transportation, Oakland County area only. Call 689-8058

LICENSED Mother will care for your child days, Monday through Friday in Plymouth. 453-7304

SALES CO-ORDINATOR, genius in sales. Tenured industrial manufacturing, O.E.M. manufacturer's Rep. \$18 week minimum. References. 522-3904, 277-6921

COMPLETE MODERNIZATION PRICED WITHIN REASON COMPLETED TO PERFECTION CUSTOM KITCHENS or Formica cover your old cabinets. FORMICA TOPS-REC ROOMS WORK MYSELF D. Bowyer LO 5-3522

Burglar & Fire Alarm AUTO ALARMS installed, work guaranteed. Your location or ours. Livonia Alarm Co. 261-5334, 459-1830

CARPENTRY CARPENTRY-ROUGH & FINISH FREE ESTIMATES 664-3852

CARPENTRY rough and finish. Experienced, licensed. No job too small. Call now. 477-9755

RAY'S INTERIORS. Custom carpentry, remodeling, additions, cabinets, paneling, formica, roofing, drywall, free estimates. 651-3339

BIRMINGHAM CARPENTER Rec. Rooms, Kitchens, Baths, Etc. Excellent references. Licensed, insured. Reasonable. 647-5142

Remodel kitchen, bath, basements. Formica counters, install dishwashers. 728-7910

CUSTOM CARPENTRY WORK Additions, Rec Rooms & Garages Roofing & Aluminum Siding Free Estimates. Licensed. 555-5336, 965-8704

CARPENTER, quality work, low prices on Kitchens, rec rooms, additions, etc. Anytime. 688-6645

512 Situations Wanted Female

LICENSED baton teacher, \$275 1/2 hour, my home or yours - Farmington or Livonia area. Specialty young beginners. Denise, after 5 PM. 478-6466

STATISTICAL typist position desired. Birmingham - Troy area. Call after 6 PM. 647-6147

HOUSEWORK wanted by experienced college student. Call Kim. 262-2330

RELIABLE WOMAN will live in. One elderly or one baby. In clean home, Livonia area. Good references. 261-3703

LICENSED Beautician wishes part-time evening work. Prefer Garden City area. 522-0822

NURSING CARE and companionship offered by experienced woman. Excellent references. 681-6805

BOOKKEEPING free lance, weekly or monthly basis, charge through P & L and balance sheet. Experienced. Your office or mine. 338-2018

BABYSITTING, ironing in my home. Joy-Middlebelt area. 427-5315

OFFERING 26 years nursing experience in my home to ambulatory elderly person. After 6 PM. 681-6805

LIMAR HOME & HEALTH CARE SERVICE has Domestic, Nurses, Companions, Sitters. Party help. All help is bonded and insured. 647-3540

514 Situations Wanted Male HANDYMAN, pool maintenance, landscaping, chauffer, etc. Will trade for living quarters. Call John, mornings, before May 1st. 542-1049

MAN, 29, wants work, full-time, days. Janitorial, porter, experienced. Excellent references. 421-1413

ROTULLING Small Garages, Free Estimates 453-9085

STUDENT to do painting, window washing, lawn maintenance, etc. Call Paul after 6 PM. 424-7189

UNIVERSITY of Michigan, undergraduate honor student seeking full-time, summer position in law office. Available May 15th through August. 851-0038

PAINTING by experienced college student, interior, exterior, wall papering, free estimates. Bill. 474-6729

EXPERIENCED painter needs work \$35 per room. Latex, your paint, no washing, patching extra. Excellent references. 422-3941

CARPENTER & Painter, 15 years exp. Basements paneled. Suspended ceilings, kitchen cabinets refinished. Reasonable prices. Free est. After 3 PM weekdays. 453-7656

518 Education Instructions PIANO instruction. Your home. Theory included. Livonia, Plymouth, Westland, Farmington area. 464-3020

CONVERSATIONAL Spanish, private and group lessons, Japanese and other languages available. Gamboa School of Languages, 13900 W. 10 Mile, Southfield, 559-3433

IBM KEYPUNCH Learn Now - Work In Weeks DAY & EVENING CLASSES FREE PLACEMENT ASSISTANCE LIVONIA BUSINESS MACHINES INSTITUTE 32114 Plymouth Rd. 261-6330

CATHY HAPPY 26th BIRTHDAY! Hee, Hee, Hee!

518 Education Instructions

GUITAR LESSONS: In your home. Acoustic and electric. All levels. Experienced teacher Howard. 626-0814

GUITAR LESSONS IN YOUR HOME 544-9830

GUITAR LESSONS, improving techniques, also beginning student, home. Livonia, 261-4187

REMEDIAL READING, learning disabilities, certified teacher, 9 years experience. MA in Room Education, recommended by local schools and colleges. 626-2787

MEDICAL ASSISTANT & RECEPTIONIST Offer (Our graduates are working) Enroll Now for April Class Ferndale Career Institute 341-0686

PIANO lessons. Class and private instruction. Call Hugh Gullidge. 455-1723

SLOBOODIAN Learning Center, Redford, \$15 weekly program. MED. PH.D. K-12 all subjects, learning disabilities. Year round and special summer programs. 425-6246

IBM KEYPUNCH Learn Now - Work In Weeks DAY & EVENING CLASSES FREE PLACEMENT ASSISTANCE LIVONIA BUSINESS MACHINES INSTITUTE 32114 Plymouth Rd. 261-6330

A FUN FILLED EVENING Ann and Donald Douglas with 28 years experience in Ball Room dancing - now holding classes at ZoAnne's. Special group rates available. Royal Oak. 399-7931

HAVING PROBLEMS? WE CAN HELP. All Subjects, All Levels. All Teachers Certified. ABLE TUTORS. 557-6014

600 Personals DEAR English Carolyn, here two months. Please get back in touch. 334-8374

BONNIE, I LOVE YOU! LIONEL CATHY HAPPY 26th BIRTHDAY! Hee, Hee, Hee!

600 Personals

JOHN DENVER TICKETS - Will trade two 7 PM for midnight performance. Call Kathy. KE 4-7483

HAPPY FIRST BIRTHDAY To Monica Kaipio. We love you. From Grandma and Grandpa Tani. 626-0814

VOLUNTEERS To work with the mentally retarded at the PLYMOUTH CENTER FOR HUMAN DEVELOPMENT 5 Mile-Sheldon Rd. Northville

Orientation sessions May 6, 8, 10 For further information contact: Volunteer Co-ordinator 453-1500, Ext. 257

MRS. BENA SPIRITUAL READER AND ADVISOR. SOLVES ALL PROBLEMS. GIVES FAST RESULTS. CALL NOW! 326-3233

602 Lost & Found FOUND: Poodle, male. Beige color. No ID. Small size. Corner Roseland and Sunset, Lathrup Village. 424-8658

LOST: African gray parrot with red tail, in vicinity of Maple Ridge and Lee Baker. 353-9168

LOST: large male cat, all black, gold eyes, vicinity 6 Mile-Beech Daily Reward. 534-1106

LOST: Brown briefcase, initials DJH. Valuable to owner. Lincoln-Telegraph-Lahser area. Reward \$60. 646-2274

LOST: black female toy poodle, answers to Nicky. Vicinity Warren and Wayne Rds. 525-3838

LOST: Very large, black dog, white chest, brown legs. Friendly. Poco, Rowland 6 Mile and Lahser. 377-7954

LOST: Female Doberman Pinscher, generous reward for information leading to recovery. 10 Mile Southfield area. 557-8008

619 Summer Camps CAMP TOSEBO FOR BOYS AGES 7 - 15 YEARS MANISTEE, MI 2 Weeks \$250 4 Weeks \$450 8 Weeks \$775

THE ALLMANDS 453-4554 (Weekdays)

ANTIQUE SHOW-SALE Next to Meadow Brook Hall ROCHESTER April 25, 26, 27 Oakland University's Sports and Recreation Building 175, Exit at University Drive to campus. Fri and Sat 10 AM-10 PM. Sun 10 AM-8 PM. Donation \$1. Free Parking. Athletic Scholarship Fund.

ANTIQUE SHOW-SALE Next to Meadow Brook Hall ROCHESTER April 25, 26, 27 Oakland University's Sports and Recreation Building 175, Exit at University Drive to campus. Fri and Sat 10 AM-10 PM. Sun 10 AM-8 PM. Donation \$1. Free Parking. Athletic Scholarship Fund.

ANTIQUE SHOW-SALE Next to Meadow Brook Hall ROCHESTER April 25, 26, 27 Oakland University's Sports and Recreation Building 175, Exit at University Drive to campus. Fri and Sat 10 AM-10 PM. Sun 10 AM-8 PM. Donation \$1. Free Parking. Athletic Scholarship Fund.

ANTIQUE SHOW-SALE Next to Meadow Brook Hall ROCHESTER April 25, 26, 27 Oakland University's Sports and Recreation Building 175, Exit at University Drive to campus. Fri and Sat 10 AM-10 PM. Sun 10 AM-8 PM. Donation \$1. Free Parking. Athletic Scholarship Fund.

ANTIQUE SHOW-SALE Next to Meadow Brook Hall ROCHESTER April 25, 26, 27 Oakland University's Sports and Recreation Building 175, Exit at University Drive to campus. Fri and Sat 10 AM-10 PM. Sun 10 AM-8 PM. Donation \$1. Free Parking. Athletic Scholarship Fund.

ANTIQUE SHOW-SALE Next to Meadow Brook Hall ROCHESTER April 25, 26, 27 Oakland University's Sports and Recreation Building 175, Exit at University Drive to campus. Fri and Sat 10 AM-10 PM. Sun 10 AM-8 PM. Donation \$1. Free Parking. Athletic Scholarship Fund.

ANTIQUE SHOW-SALE Next to Meadow Brook Hall ROCHESTER April 25, 26, 27 Oakland University's Sports and Recreation Building 175, Exit at University Drive to campus. Fri and Sat 10 AM-10 PM. Sun 10 AM-8 PM. Donation \$1. Free Parking. Athletic Scholarship Fund.

ANTIQUE SHOW-SALE Next to Meadow Brook Hall ROCHESTER April 25, 26, 27 Oakland University's Sports and Recreation Building 175, Exit at University Drive to campus. Fri and Sat 10 AM-10 PM. Sun 10 AM-8 PM. Donation \$1. Free Parking. Athletic Scholarship Fund.

ANTIQUE SHOW-SALE Next to Meadow Brook Hall ROCHESTER April 25, 26, 27 Oakland University's Sports and Recreation Building 175, Exit at University Drive to campus. Fri and Sat 10 AM-10 PM. Sun 10 AM-8 PM. Donation \$1. Free Parking. Athletic Scholarship Fund.

ANTIQUE SHOW-SALE Next to Meadow Brook Hall ROCHESTER April 25, 26, 27 Oakland University's Sports and Recreation Building 175, Exit at University Drive to campus. Fri and Sat 10 AM-10 PM. Sun 10 AM-8 PM. Donation \$1. Free Parking. Athletic Scholarship Fund.

ANTIQUE SHOW-SALE Next to Meadow Brook Hall ROCHESTER April 25, 26, 27 Oakland University's Sports and Recreation Building 175, Exit at University Drive to campus. Fri and Sat 10 AM-10 PM. Sun 10 AM-8 PM. Donation \$1. Free Parking. Athletic Scholarship Fund.

ANTIQUE SHOW-SALE Next to Meadow Brook Hall ROCHESTER April 25, 26, 27 Oakland University's Sports and Recreation Building 175, Exit at University Drive to campus. Fri and Sat 10 AM-10 PM. Sun 10 AM-8 PM. Donation \$1. Free Parking. Athletic Scholarship Fund.

ANTIQUE SHOW-SALE Next to Meadow Brook Hall ROCHESTER April 25, 26, 27 Oakland University's Sports and Recreation Building 175, Exit at University Drive to campus. Fri and Sat 10 AM-10 PM. Sun 10 AM-8 PM. Donation \$1. Free Parking. Athletic Scholarship Fund.

ANTIQUE SHOW-SALE Next to Meadow Brook Hall ROCHESTER April 25, 26, 27 Oakland University's Sports and Recreation Building 175, Exit at University Drive to campus. Fri and Sat 10 AM-10 PM. Sun 10 AM-8 PM. Donation \$1. Free Parking. Athletic Scholarship Fund.

ANTIQUE SHOW-SALE Next to Meadow Brook Hall ROCHESTER April 25, 26, 27 Oakland University's Sports and Recreation Building 175, Exit at University Drive to campus. Fri and Sat 10 AM-10 PM. Sun 10 AM-8 PM. Donation \$1. Free Parking. Athletic Scholarship Fund.

ANTIQUE SHOW-SALE Next to Meadow Brook Hall ROCHESTER April 25, 26, 27 Oakland University's Sports and Recreation Building 175, Exit at University Drive to campus. Fri and Sat 10 AM-10 PM. Sun 10 AM-8 PM. Donation \$1. Free Parking. Athletic Scholarship Fund.

ANTIQUE SHOW-SALE Next to Meadow Brook Hall ROCHESTER April 25, 26, 27 Oakland University's Sports and Recreation Building 175, Exit at University Drive to campus. Fri and Sat 10 AM-10 PM. Sun 10 AM-8 PM. Donation \$1. Free Parking. Athletic Scholarship Fund.

ANTIQUE SHOW-SALE Next to Meadow Brook Hall ROCHESTER April 25, 26, 27 Oakland University's Sports and Recreation Building 175, Exit at University Drive to campus. Fri and Sat 10 AM-10 PM. Sun 10 AM-8 PM. Donation \$1. Free Parking. Athletic Scholarship Fund.

622 Income Tax & Insurance

NO FAULT AUTO INSURANCE MOTORCYCLE INSURANCE With Top Flight Company Call A.W. Mickey 522-9470

624 Professional Services ACCOUNTING Full bookkeeping services thru financial reports and tax returns. 474-7806

626 Bingo BINGO, Vanderberg School, Tuesday, April 22nd 7:30 PM. at 16100 Edwards, Southfield. CONGREGATION BETH ACHIM 2100 W. Twelve Mile Rd. Southfield, Mich. Every WEDNESDAY 7:30 PM. Hawthorne Valley Country Club Warren & Merriman

MONDAYS 7:30 PM Beth Abraham-Hillel 5075 W. Maple Rd. (Between Middlebelt & Inkster)

MUSIC for all occasions. TV, radio and recording artists. 3 or 4 piece band plus floor show available. Tony Lee. 425-7267

THE PIPPIN PUPPETS DELIGHTFUL AND AMUSING SHOWS FOR ALL OCCASIONS. 479-0397

702 Antiques GERMAN Empire transitional sofa circa 1840. 38 in. long, 48 in. high. Hamadan rug. 609. Tiffany style lamp. 363-9411

ROLL TOP desk 54 inch mahogany executive style, excellent condition. \$395. 349-6730 after 6 PM. 453-1945

WALNUT Victorian type dining table, 6 chairs, buffet and china cabinet. Excellent condition. \$250. 353-8142

ANTIQUE SHOW-SALE Next to Meadow Brook Hall ROCHESTER April 25, 26, 27 Oakland University's Sports and Recreation Building 175, Exit at University Drive to campus. Fri and Sat 10 AM-10 PM. Sun 10 AM-8 PM. Donation \$1. Free Parking. Athletic Scholarship Fund.

ANTIQUE SHOW-SALE Next to Meadow Brook Hall ROCHESTER April 25, 26, 27 Oakland University's Sports and Recreation Building 175, Exit at University Drive to campus. Fri and Sat 10 AM-10 PM. Sun 10 AM-8 PM. Donation \$1. Free Parking. Athletic Scholarship Fund.

ANTIQUE SHOW-SALE Next to Meadow Brook Hall ROCHESTER April 25, 26, 27 Oakland University's Sports and Recreation Building 175, Exit at University Drive to campus. Fri and Sat 10 AM-10 PM. Sun 10 AM-8 PM. Donation \$1. Free Parking. Athletic Scholarship Fund.

ANTIQUE SHOW-SALE Next to Meadow Brook Hall ROCHESTER April 25, 26, 27 Oakland University's Sports and Recreation Building 175, Exit at University Drive to campus. Fri and Sat 10 AM-10 PM. Sun 10 AM-8 PM. Donation \$1. Free Parking. Athletic Scholarship Fund.

ANTIQUE SHOW-SALE Next to Meadow Brook Hall ROCHESTER April 25, 26, 27 Oakland University's Sports and Recreation Building 175, Exit at University Drive to campus. Fri and Sat 10 AM-10 PM. Sun 10 AM-8 PM. Donation \$1. Free Parking. Athletic Scholarship Fund.

ANTIQUE SHOW-SALE Next to Meadow Brook Hall ROCHESTER April 25, 26, 27 Oakland University's Sports and Recreation Building 175, Exit at University Drive to campus. Fri and Sat 10 AM-10 PM. Sun 10 AM-8 PM. Donation \$1. Free Parking. Athletic Scholarship Fund.

ANTIQUE SHOW-SALE Next to Meadow Brook Hall ROCHESTER April 25, 26, 27 Oakland

702 Antiques COLLECTOR pays cash for old... ANTIQUE Pine Harvest table... 704 Rummage Sales RUMMAGE BAKE Sale, Friday...

706 Appliances GENERAL ELECTRIC, under the... ELECTRIC Kenmore 30 in... 708 Household Goods BIRMINGHAM, variety of used...

709 Household Goods COMPLETE living room outfit... 710 Misc. For Sale EVERGREENS, uprights, spreaders...

711 Misc. For Sale LIONEL TRAIN and track... HIDDEN TREASURES Plymouth's large new thrift...

712 Misc. For Sale INTER-CITY CARPET distributors... GARAGE SALE, miscellaneous...

713 Misc. For Sale SWING SET, Remco, 220... SET of rings, 6 diamonds...

714 Misc. For Sale GREEN Lawson sofa, \$20... ATTENTION HOUSEWIVES...

715 Misc. For Sale DOG HOUSE, a real beauty... METRO Maintenance Supply...

716 Misc. For Sale GARAGE SALE, misc household... METRO Maintenance Supply...

700 Auction Sales

PUBLIC AUCTION SATURDAY, APRIL 26 Beginning at 10 AM (EST)

By Order of Irving I. Bojop, Trustee under Trust Security Agreement, Assets of UNIQUE FURNITURE GALLERIES, INC.

29277 SOUTHFIELD RD., SOUTHFIELD, MICHIGAN (Between 12 and 13 Mile Rds. in the Farrell Shopping Plaza)

FURNITURE: Hibriten 80" Sofa; Graco 87" Sofa; Lethia 87" Brown Suede Vinyl Sofa... OCCASIONAL PIECES: Carved Wood and Chrome/Glass Etagers...

INSPECTION: Friday, April 25th, 9 AM to 4:30 PM. TERMS OF SALE: 25% (cash or certified check) required at time of sale

Norman Levy Associates 21415 Civic Center • Southfield, Mich. 48076 • 313-353-8640 AUCTIONEERS • LIQUIDATORS • APPRAISERS

The Observer & Eccentric Home & Service Guide

Landscaping SHRUB AND TREE TRIMMING Seeding General Lawn Care BOB GIBSON 427-5028

Landscaping LANDSCAPE TIMBERS \$3.95 6x12x8 PATIO BLOCKS \$2.39

Lawn Maintenance ROTOTILLING Gardens and Flower Beds Free Estimate 261-6390

Lawn Maintenance S & L LANDSCAPING SPRING CLEANUPS Power Raking Rototilling Lawn Maintenance 477-0164

Painting & Decorating SPRING SPECIAL Taking estimates now Interior & Exterior \$40 a room or \$45 a day 626-7451

Painting & Decorating LOW PRICES QUALITY WORK PAINTING & WALLPAPERING

Plastering PLASTERING NEW & REPAIRS Free estimate Work guaranteed 525-4394

Pools POOL SERVICE Standard Pool Opening \$85 Acid Wash Chemicals Maintenance 525-1078

Sewer Cleaning L & L SEWER SERVICE Sewer Cleaning & Repair 24 hr service Sun-Holidays 358-6198

Landscaping EVERGREEN & shade trees all kinds, all state inspected...

Landscaping CRUSHED Gravel Topsoil/Sand from 1 to 3 yds loads...

Lawn Maintenance CLIP & SAVE PLOWING DISCING SAND GRAVEL BACKLASH SERVICE...

Lawn Maintenance LOCK SERVICE Deadlocks Locked & Installed Worn-out Locks Replaced PHIL 728-0356

Painting & Decorating INTERIOR AND EXTERIOR PAINTING Quality work Free Estimate 25 years experience 355-9110

Plastering DAN'S PLUMBING Repairs, Violations Corrected 537-9399

Pools ROOFING GUTTERS REPAIRS & VENTS Reasonable Guaranteed Work 476-2217

Sewer Cleaning SEWER CLEANING \$15 first 25 ft. 3rd clean additional \$10 PLUMBING REPAIRS CALL LEO 557-8730

Sewer Cleaning SEWING MACHINE REPAIR ECONOMY MINDED? Prompt of efficient repairs done in your home...

711 Misc. For Sale Wayne County

MAPLE TREES, 3 ft. to 15 ft. tall, 10 to 12. 728-5178
TYPEWRITERS, slide projectors, work benches, Grundig 4 band radio plus others. 421-6000
CHAIN Saw, 18 in. blade. Call after 4 PM. 533-5918
CAMPER stove with bottle gas, Commercial lawn mower, 20 gallon water pump. Stereo, adding machine. 533-2499
NATIONAL GEOGRAPHIC Magazine, all issues 1969 thru 1971, excellent condition. \$180. 281-9088
SPASH! Above ground 2 year old 15 ft. by 24 ft. beautiful Grand Fantasy Pool with 11 ft. redwood deck, includes heater, cover, and maintenance equipment. For sale by owner. Will sacrifice. Call after 6 PM. 458-2479
COMPLETE SHOPSWITH set of woodworking tools, saws, sanders, lathe. 427-6828
SWIM CLUB Membership, Newburg Swim Club, Linnova. For sale, reasonable. 626-3473
WALK Thru Rummage Sale, household items, women's clothes, 9 to 11, 72885 Santa Maria at Beaverland, West of Telegraph between 4 Mile and 7th with cue sticks and stand, good condition. \$75. 261-3485
SLOT MACHINES From \$190. 525-5347

712 Bicycles for sale

REBUILT bikes, coaster brakes, 3 speed, 3 speed, Schwinn, 3 speed. 533-4677
BICYCLE FOR TWO, 26 in., \$85. 425-8786
CONCORD 10 speed, 27 in. wheels, rack, toe clips, good condition. \$120. 477-4444
GIRL'S Schwinn 26 inch bike, \$12. Raleigh 18 inch bike, \$10. Raleigh 3 speed Girl's English bike, \$40. 942-4513
GIRLS Bicycle, 20 inch wheels, excellent condition. \$25. 455-3785

SALE 10 SPEED MEN'S BIKES

Regular \$169.95 Sale \$99.95 (In The Box) RECREATIONAL LEISURE 30717 W. 10 Mile Farmington 477-0212

714 Business & Office Equipment

TYPEWRITER, Remington electric, standard 13 inch carriage, elite, hand and desk 4020b, like new. \$425. 421-4094
TWO OFFICE side chairs, black leather, walnut frames, also large stationary cabinet. 478-3127
USED office furniture - excellent condition, 2 executive desks with credenzas, secretarial desk, 3 desks, desks, filing cabinet, side chair, IBM electric typewriter. 826-9188
DOCTOR'S examining table and miscellaneous equipment, Dags, MI 4-1923, evenings. MI 4-1949

716 Lawn-Garden & Farm Equipment

TRACTOR, 10 hp., used 3 times. \$575. 535-0643
10 HP tractor, used 3 times. \$575. 535-0643
CASE 14 HP, hi-clearance 44 tractor, blade, 48 mower, hitch chain, 1/2 ton cart, cover and plow, \$1550 for all. 375-0729
FREE Fill Sand, you pick up corner of Wakeland and Fargo. Redford Twp. 535-4858
FORK LIFT, 21 ft. high, 500 CK, excellent condition. Equip. Pacific Equipment Co., 2275 W. 8 Mile Rd. 444-1433/weekends 559-4815
SEARS CUSTOM Electric Start Tractor, with 36 in. rotary new engine last season. \$350. 851-6854
SEARS Craftsman riding mower 4 Years old, 6 HP, good condition. 852-0877

718 Building Materials

BARNWOOD 1 x 6, 30 per ft. 1 x 8, 40 per ft. 1 x 12, 50 per ft. Phone 677-7660
722 Hobbies, Coins & Stamps BUYING U.S. silver dollars and coins also Canadian pre-1966 and Kennedy halves 1965 through 1970. 455-3449
HO-TRAINS A.H.M. April Showers 1975 SALE As advertised in Railroad Magazine. SAVINGS OF 50% & OVER
JONIMO, INC. 27788 Joy Rd. 422-7952
AQUARIUM, 20 gal., fish, all accessories. \$35. 261-3488

726 Musical Instruments

NEWBURN CRESTWOOD electric hollow body guitar. Excellent condition. \$50. 723-5298
CONN, mininet organ, 2 full manuals, full octave bass pedals, excellent condition. \$400. 555-3094
SLINGERLAND drum set, 3 piece, also beginner's drum. Sparkie Blue. Must sell. 532-7665
HARPSICHORD 'NEUPERT' Just arrived from Germany. Call 965-3600, Piano Department for more information.
GRINNELLS 1515 Woodward FULL keyboard George Steck piano and bench. Fruitwood finish, like new. \$600 firm. Call. 644-5330
KING TEMPLE cornet, good condition, used 1 1/2 years. 422-1273
BUFFET clarinet, serial no. 31000, superior condition. \$600. 643-9790
KIMBALL console and bench, 3 years old, like new. \$595. 357-2547
Forming Young Band LIVONIA Best talent 14 to 18 year old rhythm, lead, bass, keyboard, and vocalist. Objective: Fun, local gigs and who knows? Have fully equipped sound proof home studio for practice and recording. Informal auditions. Call Mr. V. 523-7274
OLD upright piano. \$125. You move, needs tuning. 453-9165

726 Musical Instruments

ORGAN, Wurlitzer, multi-matic, percussion, excellent condition. \$140. (no provincial, \$65). 627-2090
GUITAR, Martin Sigma with case, \$135 or best offer. 646-5090
HAMMOND ORGAN, Cherry wood, Model M, double keyboard, percussion, reverberation, draw bars, matching Leslie speaker. \$600. 537-9430
BALDWIN FUN MACHINE It's a piano, organ, banjo, and guitar. A whole one man band that anyone can play. 3 models from \$1179 to \$2400. You won't believe it till you hear it. Open Monday thru Friday, 9:30-9 PM. Saturday 9:30-5 PM, Sun 1-5 PM. Free Parking. SMILEY BROS. 1010 N. Hunter, Birmingham MI 7-1177

728 TV, Stereo, Hi-Fi & Tape Decks

COLOR 21 inch Zenith, \$110, also color 25 inch Zenith, \$145. Both in excellent condition. 358-0017
WANTED: Spinnet or baby grand piano. Private party. 425-5113
BASS GUITAR with case, good condition, good start for beginners. \$50. 421-2522
WANTED: Spinnet or baby grand piano. Private party. 425-5113
WANTED: Spinnet or baby grand piano. Private party. 425-5113

730 Sporting Goods

GROUND trampoline, frame, 9' X 16 ft. Pad, 18" X 58". \$100. MI 6-8404
WANTED: outboard motor, around 5 H, must be in excellent condition. 453-4145
GOLF Clubs, mens Gorman, complete set, including bag. \$75. 375-9135
YORKSHIRE Terrier puppies, Purebred, male \$70. Female \$45. 728-3148
DOBERMAN pups, AKC. Beautiful, low front, Championship blood. One red, one black, both 4 months old. 562-8747
COCKER PUPS, AKC. Both healthy with excellent dispositions. Also stud service. Highland 887-9660
IRISH Wolfhound Puppies, gentle giants, pet and show quality. 652-0678

732 Wearing Apparel

MINK jacket, size 10-12, Tourmaline, paid \$800, sell \$375 firm. Like new. Little girl's complete wardrobe, size 7.5, \$25 for all. 455-3008
WEDDING Dress, size 10, beau de se beaded neck and cuff trim. \$25. 561-4145
Twin boys' clothes, 0 to 2 years, after 3PM. 476-8228

736 Wanted Misc.

WANTED: spinet piano in good condition. 642-5035
WANTED: membership for Lathrup Village Swim Club. 567-4954
WANTED: Color TV's needing repair. Must have UHF channels. Pay up to \$80. 728-5494. 261-5800
All Non-Ferrous Metals Copper 36-46c Brass 25-38c Lead 11c Aluminum 8-16c BATTERIES \$1.10
Plymouth Iron & Metal 40251 Schoolcraft Weekdays 8-4-10, Sat. 8-4-12 425-1110 453-1080
WANTED: Canoe, Grumman aluminum. 651-6173
WANTED: Bedroom Sets, Chesters, Refrigerators, Wringers, Washers, Gas Ranges, Electric clothes, Dressers and Household Ranges. 453-9729
CORRECTIVE shoeing and trimming. Steven A. Baggett. 346-7975
ARAB Gelding, 7 years old, 14 hands, bay trained English and western, must sell. 455-6209

738 Household Pets

DOG lover, tiny lovable gray poodle needs good home. \$110. 851-4247
GREAT DANE puppies, AKC registered, \$200. 348-2653. KE 4-8588
KITTENS, free to a good home. 728-9726
ENGLISH Springer Spaniel, female, Not for hunting. 837-8920
PUPPIES WANTED We find them good homes. Pet City, 23 Mile, Van Dyke. 379-8717
FREE to loving family, part terrier, 1 yr., all shots, licensed. 474-8251
POODLE pups, AKC champion line, silver, white, champagne and black. Sell to appreciate. 421-3981
Schnauzer miniature, home raised puppies, wormed, shots, trained, guaranteed. Champion stud service, professional grooming. Master Charge. BankAmericard The Albrecht's 522-8390
FREE black kittens, litter trained and wormed. Call after 4 PM. 522-4198
ADORABLE LITTERED, medium long hair, litter trained. Free to a loving home. 644-2425
ST. BERNARD, female 11 months old, spayed. Free to the right home. 647-4357
IRISH Setters, AKC, males. After 6 PM. 532-2506
FISH Aquarium, 29 gal. complete set-up. Best offer. 425-3390

800 Recreational Vehicles

IS A APACHE Is your BEST BUY! Come in and see why! Open Mon. and Thurs. till 8 PM. Open Tues. Wed., Fri., Sat., till 5:30 PM. 29070 Plymouth, Livonia, 261-1100. 20094 John R., Hazel Park, 545-9026. 10040 S. Telegraph, Taylor, 291-7175
CUSTOM made motorcycle trailer, 2 rail, plywood bed, heavy duty, \$205 or best offer. Call 652-3075
802 Snowmobiles RUPP, 1969, SnoSport. Single engine. Needs repair, \$110 or best offer. 476-2922
SKI-DOO snowmobile, 640 electric start, with reverse. New last fall! \$950. 658-5731
SNOWMOBILES, Johnson 1973, Yamaha 1974, Polaris 1971. 532-2494

804 Airplanes

FLYING CLUB, 3 Cessnas, 1 time membership fee \$50, dues \$5 month. 453-0177
HYDROPLANE, just built, must sell, great condition. 346-9056
SEE the 1975 Ventures at the Pontiac Mall, April 21st. Thurs. 27th.
BOWRIDER, 16 ft., 1972 Johnson 65 hp. Trailer, full canvas top, \$1500. Excellent shape. After 6 PM. 721-4879
SAILING Dinghy, fiberglass, aluminum spar and boom. Kick up rudder, trailer with winch. Complete with sail. \$700. After 6. 349-9751
SEA RAY 1973, 22 ft. Merc. cruiser, 100 hp. Overhaul, \$2500. 356-9186
CENTURY, 17 ft., 210 HP, inboard hull trailer, 7 pairs, water skis, clean. Weekdays, after 6 PM. 1-289-9751
SNIPER Seal sailboat, 15 1/2 ft. with trailer, \$800 or best offer. Mr. Whiteside, days, 653-1230; evenings, 349-4773
SPRINT 1973 Runabout, 14 ft., 80 HP Merc. cruiser, extinguishers, life line, 2nd seat, 2nd gear, Little Dude trailer. \$1750. Evenings. 862-3015
CHRYSLER 17 ft. boat, 140 Merc. OB, trailer, power lift, complete top, extras. \$3300. 857-3430
CATAMARAN, 16 ft., "Diamo", perfect. Includes trailer. Fast, ready to sail. \$1000. After 6 PM. 851-9455

738 Household Pets

PART Collie & St. Bernard, male, good watchdog & pet, housebroken, 3 years old. Pay for it. KE 7-4751
FREE puppies to good home. 729-9083
AKC IRISH setters, excellent blood-line. Reasonable. 535-1775
SIDERIAN Husky, AKC, female, adult shots, wormed and bagged. L.S-5-519
SHETLAND SHEEP Dogs (miniature Collie). AKC registered. Health guaranteed. Mornings: 1-434-5467
POODLE Puppies, 3 black, 3 brown. For sale immediately. \$100. 555-9031
PLUFFY black & white kitten, FREE. Call after 5. 532-6828
FREE male puppy, 4 months old, housebroken. 427-7999
LONG HAired white kittens, litter trained, \$2 each. 358-5157
BOUVIER puppies, AKC, exceptional litter, 12 weeks old, all shots, sars done. 291-1471
AKC poodle, male, black, toy, all shots. 851-3829
NORWEGIAN ELKHOUND, male, has papers, very gentle, all shots. \$150 or best offer. Call after 4:30 PM. 649-2135
PUPPIES, Collie mixed, 4 weeks old. \$7-10. 534-2910
AUSTRALIAN SHEPHERD puppies, Tris and blue merles, \$50-150. 261-0885
FREE to good home, medium long-haired kittens, weaned. GA 2-8555
AKC Cocker Spaniel puppies, 6 weeks old, tan & black. California-3855 644-1184
FREE: half Cocker, half Beagle, 8 months old, housebroken, good with children, to good home. After 6 PM. 256-1114
HONDA 500, 1972, 8,000 miles, all springer, headers. \$1500. 531-6946
SUZUKI, 1971, TS 250, low mileage. 851-1820
HONDA 1971 CB175, excellent condition. 2800 miles, adult owned & 2nd year. 427-1292
HARLEY DAVIDSON Sportster, 1971, full custom. \$1800. 453-0665
TRIUMPH 1972, TR-4, very good condition, low mileage. \$1200. 534-8727
HONDA 1973, 300, 2 helmets, padded seats, rack, 4,500 miles, excellent condition. \$1,200 or best offer. 485-3374 or 722-9696
SPORTSTER 1971, 900cc, 6000 miles, excellent condition, partly customized. \$1,800. 349-7106 or 453-4159
KAWASAKI 1973, Mach III, 9000 Good condition. 457-5003
HONDA 1970, SL 175, good condition. \$350. 535-4821
YAMAHA 1973, 650cc, new condition. 450 miles. \$1,500. Call after 5 PM. 477-7824
SPORTSTER 1970, HXL, assembled, semi custom and paint, clean, hardly ridden 1850, or trade for bike with side car or bike alone. Must sell. 422-5555
YAMAHA 1974 750, low mileage. \$1200. 422-4407
YAMAHA 360 Enduro 1972, great shape, asking \$475. 851-9516
HONDA 1971, 350 Scrambler, new paint, candy apple red. \$450. 641-6743
HONDA 1975 CB 750, only 3000 miles, helmet and camera with bike, asking \$1950, or best offer. 326-6539
KAWASAKI 1973 750, 5,000 miles, gold, excellent condition. \$1400. 459-3834
KAWASAKI, 1973, F1, 250 cc, clean, 1400 miles, \$725. 421-6740
HONDA 250 Scrambler, best offer or will trade for canoe or smaller bike. 427-4365
TRIUMPH 1972 500, low mileage, \$975 or best offer. 349-2526
TRIUMPH 1974 Trident, less than 800 miles, like new. 346-9992
SUZUKI, 1971, TS 250. Excellent condition. 6,000 miles. \$450. 628-7725
HONDA, 1971, 500, 6,000 miles. Wisconsin Faring, very good condition. \$1150. 464-3157
SEVEN YEAR Gelding, quarter and Morgan, Family dignified with spirit. 651-6468

810 Insurance

MOTORCYCLE INSURANCE Competitive Rates 453-8234

812 Motorcycles, Go-Karts-Mini Bikes

HONDA 1970, CT70, trail, automatic clutch, under 1200 miles. \$225. 453-7333
SUZUKI 1974, TM 125, Excellent condition. 421-1965
KAWASAKI, 1972, 100 factory race, very good condition. Extra parts. 349-0656
HONDA 1973, XR75, good condition. Hooker exhaust. \$275. 349-9056
HONDA 1974, CB 350, real dual seat, extra dimple, central vacuum. As new throughout. Cruise stereo tape dual air, rack, hitch, etc. \$2,500. 354-6727
WAY-WE-GO 1970, excellent condition, sleeps 8, fully equipped. 533-2153
NORRIS 1962, 16 ft., self contained, excellent condition. call 477-4765
OPEN ROAD, 23 ft. Statesman motor home, reduced to \$6,900. 2,000 watt generator, 11 mpg, 5.50 liter engine. 642-7976
LIL DARLIN' 1974 truck camper, slow, low, low base, storage space, sleeps 4, like new. \$600. 538-1310
AVION, 26 ft. 1973, air conditioning, deluxe interior, stereo, mint condition. Less than 5,000 miles. Asking \$6,800. Call after 5 PM. 474-4883

814 Campers and Motorhomes

GMC yellow, 260 motor home, small type, new January, 1974, 1973 interior layout and key 1975 model. Loaded with many hard to find factory options: dual seat, extra dimple, central vacuum. As new throughout. Cruise stereo tape dual air, rack, hitch, etc. \$2,500. 354-6727
WAY-WE-GO 1970, excellent condition, sleeps 8, fully equipped. 533-2153
NORRIS 1962, 16 ft., self contained, excellent condition. call 477-4765
OPEN ROAD, 23 ft. Statesman motor home, reduced to \$6,900. 2,000 watt generator, 11 mpg, 5.50 liter engine. 642-7976
LIL DARLIN' 1974 truck camper, slow, low, low base, storage space, sleeps 4, like new. \$600. 538-1310
AVION, 26 ft. 1973, air conditioning, deluxe interior, stereo, mint condition. Less than 5,000 miles. Asking \$6,800. Call after 5 PM. 474-4883

CHAMPION CONCORD TITAN

Motorhomes - Show Prices H.W. Auto Sales 453-6535

816 Auto Parts & Service

TIAGA 1973 19 ft. mini-home, 5,600 miles. \$7,700 or best offer. 682-7615
FORD 1970, with 1971-11 ft. Campervan, self contained, good condition. \$2,700. 453-3294
COX folding camper, sleeps 6, good condition. \$650. Call after 5 PM. 474-0244
WARD'S camper, sleeps 4, used twice, sacrifice. \$250. Call after 6 PM. 525-7946
APACHE, 1973, Eagle, sleeps 6, good condition. Call after 5 PM. 261-5542
STARCRAFT 1972, Hardtop camper trailer. Sleeps 6, excellent condition. \$600. 478-0982
DODGE 1967 Van \$200. 453-1981
FORD 1973 window van 4 1/2 ton, 6 cylinder automatic. Low mileage. Good condition. 355-1378
CHEVY 1965 pickup \$250. 453-5823
FORD, 1967, Econoline van, 240 engine, automatic, best offer. 261-8004
1974, Chevy Van, power brakes, steering, stereo, interior completely carpeted. \$97-9095
USED TIRES ON WHEELS, \$5 and up. Starters, alternators, batteries, \$5 exchange. 474-8739

820 Autos Wanted

VW'S WANTED ALL YEARS-ALL MODELS TOP \$\$ PAID IMMEDIATE CASH OPEN SATURDAY TOM SULLIVAN VOLKSWAGEN 25400 W. 8 Mile 353-6900
WE BUY USED CARS ALL MAKES & MODELS ALSO TRUCKS OPEN SATURDAYS
Bill Brown USED CARS 35000 Plymouth Rd. Livonia, Michigan 427-9700
Car For Sale WE WELCOME YOU WITH OPEN WALLET Because we sell so many, we need good used cars of all kinds. We pay CASH and need cars NOW.

Bob Saks

478-0500 Farmington

WE ARE BUYING NOW HIGH DOLLAR

All Makes & Models Including Sports & Performance Cars FREE APPRAISAL BOB SELLERS PONTIAC 22520 Grand River KE5-7600

ALWAYS TOP DOLLAR

For 1969-1974 clean cars and trucks. AVIS FORD 354-3105

Always Bigger Cash Sharp Late Model Cars NEEDED NOW

FOR OUT OF STATE MARKET Mansfield Auto Sales 1104 Baldwin Pontiac FE 5-9025

821 Junk Cars Wanted

UP TO \$60 paid for old wrecks and junk cars. Bob's Towing, 217-2597
\$ CASH \$ 55c PER 100 LBS. For Junk Cars G & L Auto Wrecking 537-4456

806 Boats & Motors

ALUMINUM BOAT 13 ft 2 ft motor, trailer. \$350. 422-5345
ARCOFACET, 18 ft. fiberglass trailer, 35 HP Johnson, electric start, 13 ft. ladder, jackets, tanks. \$600. 522-3944 or 577-0881
C-Lark sailboat, 14 ft. Spinnaker, 2000 sq. ft. \$1650. 522-6888
SAVE \$200. 1974 Laser 12ft 1/2 ft. sailboat. Only used 4 times. \$880. 74-5454
16 FOOT Glastron, GT-100, ski and pleasure boat, Merc. 800, trailer. Call for condition. 453-3573
SEXTANT BY PLATH, Imported, precision instrument. Perfect condition. 456-0674
CANOE, Sailboat, Old Town, 16 ft. custom Brass fittings, 4 cars, excellent condition. \$600 firm. 453-9094
SIROCCO 15 Day Sailor, or weekenders. Large cabin. Main sail & boom. 5.5 HP roller rearing. 2 Seasons old. New 5.5 HP motor. Trailer. Any time. 973-2744

810 Insurance

MOTORCYCLE INSURANCE Competitive Rates 453-8234

812 Motorcycles, Go-Karts-Mini Bikes

HONDA 1970, CT70, trail, automatic clutch, under 1200 miles. \$225. 453-7333
SUZUKI 1974, TM 125, Excellent condition. 421-1965
KAWASAKI, 1972, 100 factory race, very good condition. Extra parts. 349-0656
HONDA 1973, XR75, good condition. Hooker exhaust. \$275. 349-9056
HONDA 1974, CB 350, real dual seat, extra dimple, central vacuum. As new throughout. Cruise stereo tape dual air, rack, hitch, etc. \$2,500. 354-6727
WAY-WE-GO 1970, excellent condition, sleeps 8, fully equipped. 533-2153
NORRIS 1962, 16 ft., self contained, excellent condition. call 477-4765
OPEN ROAD, 23 ft. Statesman motor home, reduced to \$6,900. 2,000 watt generator, 11 mpg, 5.50 liter engine. 642-7976
LIL DARLIN' 1974 truck camper, slow, low, low base, storage space, sleeps 4, like new. \$600. 538-1310
AVION, 26 ft. 1973, air conditioning, deluxe interior, stereo, mint condition. Less than 5,000 miles. Asking \$6,800. Call after 5 PM. 474-4883

CHAMPION CONCORD TITAN

Motorhomes - Show Prices H.W. Auto Sales 453-6535

816 Auto Parts & Service

TIAGA 1973 19 ft. mini-home, 5,600 miles. \$7,700 or best offer. 682-7615
FORD 1970, with 1971-11 ft. Campervan, self contained, good condition. \$2,700. 453-3294
COX folding camper, sleeps 6, good condition. \$650. Call after 5 PM. 474-0244
WARD'S camper, sleeps 4, used twice, sacrifice. \$250. Call after 6 PM. 525-7946
APACHE, 1973, Eagle, sleeps 6, good condition. Call after 5 PM. 261-5542
STARCRAFT 1972, Hardtop camper trailer. Sleeps 6, excellent condition. \$600. 478-0982
DODGE 1967 Van \$200. 453-1981
FORD 1973 window van 4 1/2 ton, 6 cylinder automatic. Low mileage. Good condition. 355-1378
CHEVY 1965 pickup \$250. 453-5823
FORD, 1967, Econoline van, 240 engine, automatic, best offer. 261-8004
1974, Chevy Van, power brakes, steering, stereo, interior completely carpeted. \$97-9095
USED TIRES ON WHEELS, \$5 and up. Starters, alternators, batteries, \$5 exchange. 474-8739

820 Autos Wanted

VW'S WANTED ALL YEARS-ALL MODELS TOP \$\$ PAID IMMEDIATE CASH OPEN SATURDAY TOM SULLIVAN VOLKSWAGEN 25400 W. 8 Mile 353-6900

WE BUY USED CARS ALL MAKES & MODELS ALSO TRUCKS OPEN SATURDAYS

Bill Brown USED CARS 35000 Plymouth Rd. Livonia, Michigan 427-9700

Car For Sale

WE WELCOME YOU WITH OPEN WALLET Because we sell so many, we need good used cars of all kinds. We pay CASH and need cars NOW.

Bob Saks

478-0500 Farmington

WE ARE BUYING NOW HIGH DOLLAR

All Makes & Models Including Sports & Performance Cars FREE APPRAISAL BOB SELLERS PONTIAC 22520 Grand River KE5-7600

ALWAYS TOP DOLLAR

For 1969-1974 clean cars and trucks. AVIS FORD 354-3105

Always Bigger Cash Sharp Late Model Cars NEEDED NOW

FOR OUT OF STATE MARKET Mansfield Auto Sales 1104 Baldwin Pontiac FE 5-9025

821 Junk Cars Wanted

UP TO \$60 paid for old wrecks and junk cars. Bob's Towing, 217-2597

\$ CASH \$ 55c PER 100 LBS. For Junk Cars

G & L Auto Wrecking 537-4456

821 Junk Cars Wanted

JUNK CARS and trucks wanted, any condition. Immediate pickup. Days or evenings. 728-8946
HIGH\$HIGH\$ WANTED \$25 - \$50 ON ALL Junk Cars Must Have Title CITY AUTO RECOVERY 40111 Schoolcraft 453-3411 261-9120 PLYMOUTH

Wanted Junk Cars

55c PER 100 LBS. FAST PICK-UP CALL D. & J. Auto Wrecking 474-4425

NEED A TOW? LET US KNOW

BAKERS BROS. TOWING Road Service and Towing JUNK CARS 525-4388

JUNK CARS WANTED

FREE PICK-UP 739-3333-268-1090

822 Trucks for sale

FORD 1973 custom club wagon, 8 passenger, automatic, power steering, power brakes, low mileage. Like new. \$2500. 649-0929
GMC, 1971, Gimmy, with snow plow, 4 wheel drive. \$2800. 358-2796
FORD 1973 F250 Ranger XLT, \$1000 GVW, camper special, plus extra options. \$3,225. 455-1983
HORNET Sport about wagon, 1971, \$1800. After 2:30 PM. 644-0929
GMV, 1971, Gimmy, with snow plow, 4 wheel drive. \$2800. 358-2796
FORD 1973 F250 Ranger XLT, \$1000 GVW, camper special, plus extra options. \$3,225. 455-1983
CHEVROLET Beauville van 1974, 4 ton, long wheel base, power steering & brakes, air, automatic, extra bench seat plus more. \$4850. 427-2084
GRAND OPENING SPECIAL 1974 Dodge D-300 Hippie Van. Completely customized inside, air conditioning, AM-FM stereo with 8 track tape, 5 brand new tires, 14,000 miles. Van is ready to Boogie. 477-4883

ROLLIE BARRETT

30777 Plymouth Rd. 525-5000

DODGE 1972, 4 wheel drive

866 Ford
FORD 1966, good transportation. Best offer. Call between 2PM and 6PM. 455-3355
TORINO, 1971, 302 automatic, 6500 or best offer, good condition. 455-7429
FORD 1968, LTD Sport, power steering, brakes, automatic, console. Runs good. Best offer. 725-1188, 261-2873
FORD, 1967, LTD, nice condition. 477-2519
PINTO, 1971, 3 door, automatic, radio, excellent condition. 447-4110

GRAND OPENING SPECIAL! 1972 Ford Torino GT, 3 way power, dark blue with white vinyl top, radio, whitewalls. PRICED TO SELL

ROLLIE BARRETT
30777 Plymouth Rd.
525-5000

MUSTANG 1974, Mach I, stereo, air, power steering, brakes, loaded. 626-2027
LTD, 1972, Brougham, air, steel radials, must sell. 478-1718
MAVERICK 1975, loaded. Have to sell. Contact After 5 PM. 453-1341

FORD 1967, yellow Country Sedan, air, good tires, good 2nd car transportation. \$350. After 3. 261-1004
TORINO, 1972, wagon, power, AM-FM, 7 tires including new snows. Best offer over \$1700. 641-7101

MUSTANG, 1971, V-8, automatic, power steering, power brakes, vinyl top, many extras. \$1995. 474-2755
FORD 1967, Fairlane, 2 door hard top, 8 automatic, power, no rust, mechanically perfect. 273-7561

MAVERICK, 1971, standard transmission, \$1000. After 6 PM. 261-3135
LTD 1974, 2 door, air, \$3200. 851-6239

75 USED CARS
To choose from. Fully reconditioned, 1 year free warranty.

Calhoun FORD
41001 Plymouth Rd.
Plymouth
453-1327

MUSTANG 1974, Ghia, power steering, power brakes, air conditioning, V-8, radials, aluminum wheels, AM-FM stereo, other extras, under 5000 miles. \$3,700. 326-4046
MAVERICK 1974, 2 door, radio, automatic, power steering, steel radials. Excellent condition. \$2,495. 446-5990

PINTO, 1973, Squire wagon, 12,000 miles. Excellent condition. \$1,850. 682-9154
MAVERICK 1970, 1 owner, very good condition. \$450 or best offer. After 5 PM. 645-0835

MUSTANG 1973, V-8, radio, heater, automatic, power steering, vinyl roof, low mileage, owner. 474-8552
FAIRLANE, 1968, Fastback, 4 speed, 302, Right hand fender damage. No rust, new rear tires. 421-5453

PINTO 1971, 2000 engine, 4 speed, Ziebart, 45,000 miles, radio, tires. \$950. 356-7237
MUSTANG 1972, 302 V-8, air conditioning, automatic transmission, power steering, brakes, vinyl top, radio, 28,000 miles, excellent condition. \$1,875. After 5 PM. 453-1062

PINTO 1972, Runabout, automatic, new exhaust, shocks. \$1100. 421-1092

MICHIGAN'S #1 Ford Dealer WHY? We Sell For Less! Large Savings On All Models. STARK HICKEY WEST

24760 W. 7 Mile 538-6600
CORTINA, 1968, runs well, body has some rust. \$150. 455-6209
PINTO 1974, Hatchback, 4 speed, stick, 6 cylinder, radio, a gem! \$1195. Call mornings. 349-2821

MAVERICK 1972, 6 cylinder, automatic, 7500. Call mornings. 349-2821
TORINO GT 1968, well maintained, power steering, power disc brakes, excellent 8000. 642-3949 or 545-9223

LTD, 1970, Brougham, 2 door, V8, automatic, air, good condition. After 6 PM. 522-2929
GALAXIE 500, 1969, good tires, good mechanical condition. \$500. 551-1073

PINTO, 1972, Squire Wagon, 14,000 miles, 4 speed, AM, radials, clean. 1 Owner. Call Jane. 349-6878

1973 MUSTANG MACH I
Hurst 4 speed, radio, heater, 13,000 actual miles. Real sharp. \$2,895.
PAT MILLIKEN FORD
9600 Telegraph
Between Plymouth & W. Chicago
255-5840

866 Ford
GALAXIE, 1972, 500, Power steering, power brakes, air. Needs work. Best offer. Call after 6 PM. 459-3859
MUSTANG 1971, 351, automatic transmission, Power steering, power brakes. Rear window defroster. \$1,750. 851-0575

PINTO 1974, Squire wagon, Air, AM-FM Stereo, automatic. Excellent condition. \$2650. After 5 PM. 477-2029
MAVERICK 1971, automatic, air, 22,000 miles. \$995. 349-6032
FALCON 1965, hardtop, 289-4 speed, good condition. \$150. 331-8787

FAIRLANE, 1968, 6 cylinder, 2 door, automatic, power steering, new tires, battery, 44,000 miles, good condition. \$475. 477-0196
TORINO 1971, \$495. 533-1880. 355-0719
PINTO 1974, 3 door, 2.3 litre, 4 speed. \$2350 or best offer. 455-9305
LTD, 1968, Brougham, power steering, power brakes, air, radio, good condition. \$450. 261-7234

TORINO station wagon, 1968. 522-9261
PINTO SQUIRE wagon, 1973, 4 speed, AM radio, air, 23 MPG, sharp. \$2,550. 261-2196

870 Jeep
JEEP RENEGADE, 1975, white & blue Levi, heavy duty cooling and suspension, rust proofed, front wheel, 4,000 miles. \$5,000. 651-1964 offer.
872 Lincoln
LINCOLN, 1975, 4 door, metallic gold, matching roof and interior, loaded, 7,000 miles. Save \$8 Art Moran Pontiac. 353-9000

MARK IV 1972, White. Exceptionally clean. Wife's car. Low mileage. Must be seen. \$4,595. After 5 PM. 546-1253
CONTINENTAL 1974, 4 door, Private owner. \$5,495. 626-2655

LINCOLN 1973, 2 door, one owner, very clean, red with white top. Leather interior, full power options. 474-6084
CONTINENTAL, 1974, executive car, cruise, tilt, stereo, locks, computer brakes, white sun roof over special Moon dust Firemist paint, low mileage. \$3850. Car telephone available too. Bloomfield Hills. 358-3828

874 Mercury
COMET, 1974, low mileage, 4 door, fully equipped, including air conditioning. 459-9202
COMET 1974, 4 door, Air, low mileage, fully equipped. \$3000. Call anytime. 459-9202

MONTREY 1971 2 door, air, power steering, brakes, vinyl top. One owner. Excellent. \$1250. 477-2072
1974 CAPRIS, V-6, 4 speed, decor group, 7,000 actual miles. Free 12 month warranty. Buy now and save. \$3,495. 446-5990

HINES PARK
LINCOLN MERCURY
ANN ARBOR RD. AT HAGGERTY
453-2424 425-2444
MONTEGO MX, 1972 Brougham, one owner, good condition, power steering, brakes, low mileage. \$1500. 861-7653
MONTEGO 1972 wagon, needs valve job \$500. See at Ford - Venoy Gulf.
1975 MONTEGO MX 2 door hardtop, automatic, power, radio and vinyl top. 8,000 actual miles, like new. Extra clean. See and drive for \$4,195.

876 Oldsmobile
CUTLASS, 1975, Supreme, 4 month old, power, complete warranty, loaded with extras. Must Sell. \$5100. Mon. thru Fri. 9-5 PM. 474-1811. After 5 PM. 538-8891
OMEGA, 1974, Hatchback, 6 cyl. AM-FM, power steering, mist cond. \$1,100. 851-5132
'73 OLDS CUTLASS
Coupe, 18,000 actual speedo miles, bucket seats, console, 300 V-8 engine, power steering, power brakes. Factory air conditioning, steel belted radial tires. Mint condition. Asking
\$2,995
BOB SELLERS PONTIAC
LOW OVERHEAD EQUALS
LOW PRICES
22520 Grand River KES-7600

DELTA 88, 1973, 2 door vinyl top, automatic transmission. Power steering, brakes, air conditioning, clean. 40,000 miles. \$2150. 647-2058
VISTA Cruiser 1972 wagon, all power, radio, air conditioning, rust proofed. One owner. \$2200. 453-4874

'73 CUTLASS
V-8, automatic, power steering, power brakes, AM-FM radio, air conditioning, vinyl top with sun roof. \$2,995.
'OPEN SATURDAY
TOM SULLIVAN
VOLKSWAGEN
25400 W. 8 Mile 353-8900

OLDSMOBILE 1968 442, Convertible, air conditioning, am-fm stereo, real clean. Runs good. 474-5195
OLDS, 1966, automatic, power steering, brakes, Radio, \$375. 375-9835

878 Plymouth
FURY II, 1968, \$350, good running condition. Needs tires. 281-9653
DUSTER 1973, automatic, AM-FM stereo, excellent condition. \$1,800. Call after 5 PM. 382-0663

PLYMOUTH 1972, Series II, air conditioning, low mileage, full power, \$1500. Plymouth 173 Fury III, full power, air conditioning, low mileage. \$2350. Contact Business Manager, Madonna College. 425-8000

DUSTER 1970, 318, 3 speed, dependable transportation. New tires, best offer. 408-1237

GRAND OPENING SPECIAL! 1973 Plymouth Duster, automatic transmission, power steering, radio, whitewalls, like new. 29,000 miles. A MUST SEE CAR!

ROLLIE BARRETT
30777 Plymouth Rd.
525-5000

DUSTER, 1970, stick shift, low mileage. \$650. 453-4079

GOLD DUSTER 1973, package, stereo, 225 engine, automatic, power steering. \$2175. 422-4785

GRAND OPENING SPECIAL! 1974 Satellite Sebring, 2 door hardtop, automatic, power steering, factory air, vinyl top, radio, whitewalls, extended factory warranty, approximately 11,000 actual miles. HURRY ON THIS ONE!

ROLLIE BARRETT
30777 Plymouth Rd.
525-5000

GRAND PRIX, 1973, power steering, brakes, AM-FM, power windows, air. Call before 5 PM. 533-9647

GRAND AM, 1973, 4 door, loaded, low mileage, excellent condition. 642-2768

1968 FIREBIRD
6 cylinder, automatic transmission, power steering, radio, good tires. Real clean car. Asking
\$1,195
BOB SELLERS PONTIAC
LOW OVERHEAD EQUALS
LOW PRICES
22520 Grand River KES-7600

CATALINA, 1966 convertible, automatic, good running condition, 28223 Whitcomb, Livonia, 6 Mile & Harrison.
CATALINA, 1968, air power steering, power brakes, excellent condition. \$750. GA 5-6929

1973 CATALINA
2 door hardtop, AM-FM radio, factory air conditioning, power steering, power brakes, radial tires, low miles, asking
\$2,350
BOB SELLERS PONTIAC
LOW OVERHEAD EQUALS
LOW PRICES
22520 Grand River 532-8720

GRANDVILLE, 1974, 4 door hardtop, fully loaded, super clean. \$3900. 528-4332

GRAND PRIX, 1973, power steering, brakes, AM-FM, power windows, air. Call before 5 PM. 533-9647

GRAND AM, 1973, 4 door, loaded, low mileage, excellent condition. 642-2768

880 Pontiac
HURRY SPRING SAVERS
66 VW Camper \$1,995
73 Charger SE, loaded \$1,495
73 Chevy Newport, air \$2,295
73 Ford Pickup, auto \$2,295
74 Dusters, 3 from \$2,295
74 Ply. Satellite, V8 \$2,995
71 VW Bus, air \$1,995

FEISTER CHRYSLER-PLYMOUTH
37401 Ford Rd. at Newburgh
721-2400
FURY III, 1969, 4 door, turtle top, power steering & brakes, excellent condition. \$750. Evenings. 537-9569

GRAND OPENING SPECIAL! 1974 Satellite Sebring Plus, 2 door hardtop, red with white vinyl top, 3 way power, AM-FM stereo, factory air, rally wheels, 11,000 miles. One owner. MUST SEE TO BELIEVE!

ROLLIE BARRETT
30777 Plymouth Rd.
525-5000

GRAND PRIX 1974, air, AM-FM, power steering, power brakes, other extras. \$2,500. After 5 PM. 450-0211

CAR CLEARANCE
72 Ford Gd Torino, air \$1,384
72 Chry Newport, air \$1,989
71 Chry 300, pb, ps \$1,295
72 Duster, auto, power \$1,337
73 Buick 225, loaded, air \$2,774
71 Chry T & C wgn, air \$1,295
71 Dameron Chry-Ply G'd River at Middlebelt 476-7900

ROAD RUNNER 1969, 383 4 speed, AM-FM stereo 8 track, new tires, new shocks. Good condition. \$850 or best offer. 437-0408

880 Pontiac
CATALINA 1973 9 passenger wagon, factory air, am-fm radio, power steering & brakes, power tall gate, luggage rack. 28,000 miles. \$2300.
'74 GRAND SAFARI
9 passenger wagon, only 15,000 miles. Factory air conditioning, steel belted radial tires, all power assists. True luxury in this fine family and utility wagon. We're only asking
\$4,395
BOB SELLERS PONTIAC
LOW OVERHEAD EQUALS
LOW PRICES
22520 Grand River KES-7600

GRAND PRIX, 1973, 3 way power, stereo, air, low mileage, original owner. \$2550. 349-7473

PONTIAC Catalina 1973, 2 door hardtop, power steering, power brakes, am-fm air conditioning, low miles, mag wheels. Must sell by April 21. Best offer over \$2,000. 464-2065

CATALINA 1972, All extras, \$1650. 348-2710

'74 LUXURY LeMANS
2 door, 13,000 miles, radio, heater, automatic transmission, 350 c.u. V-8 engine, power steering, brakes, factory air conditioning, vinyl roof. Showroom fresh. We're only asking
\$3,595
BOB SELLERS PONTIAC
LOW OVERHEAD EQUALS
LOW PRICES
22520 Grand River KES-7600

FIREBIRD 1974, rally wheels, duals, 350 air conditioning, power steering, power brakes. \$3,500. 394-0731

T-37, 1971, air, 2 door, power brakes, steering, snows, low mileage. \$1095. 642-3382

882 Thunderbird
T-BIRD 1973, AmFm stereo, speed control, leather trim, loaded, excellent condition. \$3,850. 455-2855

T-BIRD 1974, 22,000 miles, stereo radio, cruise control, leather interior, air, many other extras. Call weekdays, Mr. Thornley. 349-8600

VOLKSWAGEN 1969 Karmann Ghia, \$900. 427-8979

VOLKSWAGEN 1970 Squareback sedan, AM-FM radio, hitch, custom accessories for camping. Good condition. 838-2953

VW 1969 Bug, excellent condition, 22,000 actual miles. \$875 or best offer. 335-1141

1968 FIREBIRD
6 cylinder, automatic transmission, power steering, radio, good tires. Real clean car. Asking
\$1,195
BOB SELLERS PONTIAC
LOW OVERHEAD EQUALS
LOW PRICES
22520 Grand River KES-7600

CATALINA, 1966 convertible, automatic, good running condition, 28223 Whitcomb, Livonia, 6 Mile & Harrison.
CATALINA, 1968, air power steering, power brakes, excellent condition. \$750. GA 5-6929

1973 CATALINA
2 door hardtop, AM-FM radio, factory air conditioning, power steering, power brakes, radial tires, low miles, asking
\$2,350
BOB SELLERS PONTIAC
LOW OVERHEAD EQUALS
LOW PRICES
22520 Grand River 532-8720

GRANDVILLE, 1974, 4 door hardtop, fully loaded, super clean. \$3900. 528-4332

GRAND PRIX, 1973, power steering, brakes, AM-FM, power windows, air. Call before 5 PM. 533-9647

GRAND AM, 1973, 4 door, loaded, low mileage, excellent condition. 642-2768

882 Thunderbird
T-BIRD 1973, AmFm stereo, speed control, leather trim, loaded, excellent condition. \$3,850. 455-2855

T-BIRD 1974, 22,000 miles, stereo radio, cruise control, leather interior, air, many other extras. Call weekdays, Mr. Thornley. 349-8600

VOLKSWAGEN 1969 Karmann Ghia, \$900. 427-8979

VOLKSWAGEN 1970 Squareback sedan, AM-FM radio, hitch, custom accessories for camping. Good condition. 838-2953

VW 1969 Bug, excellent condition, 22,000 actual miles. \$875 or best offer. 335-1141

1968 FIREBIRD
6 cylinder, automatic transmission, power steering, radio, good tires. Real clean car. Asking
\$1,195
BOB SELLERS PONTIAC
LOW OVERHEAD EQUALS
LOW PRICES
22520 Grand River KES-7600

CATALINA, 1966 convertible, automatic, good running condition, 28223 Whitcomb, Livonia, 6 Mile & Harrison.
CATALINA, 1968, air power steering, power brakes, excellent condition. \$750. GA 5-6929

1973 CATALINA
2 door hardtop, AM-FM radio, factory air conditioning, power steering, power brakes, radial tires, low miles, asking
\$2,350
BOB SELLERS PONTIAC
LOW OVERHEAD EQUALS
LOW PRICES
22520 Grand River 532-8720

GRANDVILLE, 1974, 4 door hardtop, fully loaded, super clean. \$3900. 528-4332

GRAND PRIX, 1973, power steering, brakes, AM-FM, power windows, air. Call before 5 PM. 533-9647

880 Pontiac
HURRY SPRING SAVERS
66 VW Camper \$1,995
73 Charger SE, loaded \$1,495
73 Chevy Newport, air \$2,295
73 Ford Pickup, auto \$2,295
74 Dusters, 3 from \$2,295
74 Ply. Satellite, V8 \$2,995
71 VW Bus, air \$1,995

FEISTER CHRYSLER-PLYMOUTH
37401 Ford Rd. at Newburgh
721-2400
FURY III, 1969, 4 door, turtle top, power steering & brakes, excellent condition. \$750. Evenings. 537-9569

GRAND OPENING SPECIAL! 1974 Satellite Sebring Plus, 2 door hardtop, red with white vinyl top, 3 way power, AM-FM stereo, factory air, rally wheels, 11,000 miles. One owner. MUST SEE TO BELIEVE!

ROLLIE BARRETT
30777 Plymouth Rd.
525-5000

GRAND PRIX 1974, air, AM-FM, power steering, power brakes, other extras. \$2,500. After 5 PM. 450-0211

CAR CLEARANCE
72 Ford Gd Torino, air \$1,384
72 Chry Newport, air \$1,989
71 Chry 300, pb, ps \$1,295
72 Duster, auto, power \$1,337
73 Buick 225, loaded, air \$2,774
71 Chry T & C wgn, air \$1,295
71 Dameron Chry-Ply G'd River at Middlebelt 476-7900

ROAD RUNNER 1969, 383 4 speed, AM-FM stereo 8 track, new tires, new shocks. Good condition. \$850 or best offer. 437-0408

880 Pontiac
TEMPEST 1967, 6 cylinder, power steering, power brakes, automatic, good condition, new tires. \$22,774

GRAND PRIX, 1971, air, automatic, power steering, power brakes. Excellent condition. \$1895. 328-4346

EXECUTIVE, 1967, 4 door, automatic, power steering & brakes. \$250. 477-5544

1968 FIREBIRD
6 cylinder, automatic transmission, power steering, radio, good tires. Real clean car. Asking
\$1,195
BOB SELLERS PONTIAC
LOW OVERHEAD EQUALS
LOW PRICES
22520 Grand River KES-7600

CATALINA, 1966 convertible, automatic, good running condition, 28223 Whitcomb, Livonia, 6 Mile & Harrison.
CATALINA, 1968, air power steering, power brakes, excellent condition. \$750. GA 5-6929

1973 CATALINA
2 door hardtop, AM-FM radio, factory air conditioning, power steering, power brakes, radial tires, low miles, asking
\$2,350
BOB SELLERS PONTIAC
LOW OVERHEAD EQUALS
LOW PRICES
22520 Grand River 532-8720

GRANDVILLE, 1974, 4 door hardtop, fully loaded, super clean. \$3900. 528-4332

GRAND PRIX, 1973, power steering, brakes, AM-FM, power windows, air. Call before 5 PM. 533-9647

GRAND AM, 1973, 4 door, loaded, low mileage, excellent condition. 642-2768

882 Thunderbird
T-BIRD 1973, AmFm stereo, speed control, leather trim, loaded, excellent condition. \$3,850. 455-2855

T-BIRD 1974, 22,000 miles, stereo radio, cruise control, leather interior, air, many other extras. Call weekdays, Mr. Thornley. 349-8600

VOLKSWAGEN 1969 Karmann Ghia, \$900. 427-8979

VOLKSWAGEN 1970 Squareback sedan, AM-FM radio, hitch, custom accessories for camping. Good condition. 838-2953

VW 1969 Bug, excellent condition, 22,000 actual miles. \$875 or best offer. 335-1141

1968 FIREBIRD
6 cylinder, automatic transmission, power steering, radio, good tires. Real clean car. Asking
\$1,195
BOB SELLERS PONTIAC
LOW OVERHEAD EQUALS
LOW PRICES
22520 Grand River KES-7600

CATALINA, 1966 convertible, automatic, good running condition, 28223 Whitcomb, Livonia, 6 Mile & Harrison.
CATALINA, 1968, air power steering, power brakes, excellent condition. \$750. GA 5-6929

1973 CATALINA
2 door hardtop, AM-FM radio, factory air conditioning, power steering, power brakes, radial tires, low miles, asking
\$2,350
BOB SELLERS PONTIAC
LOW OVERHEAD EQUALS
LOW PRICES
22520 Grand River 532-8720

GRANDVILLE, 1974, 4 door hardtop, fully loaded, super clean. \$3900. 528-4332

GRAND PRIX, 1973, power steering, brakes, AM-FM, power windows, air. Call before 5 PM. 533-9647

GRAND AM, 1973, 4 door, loaded, low mileage, excellent condition. 642-2768

880 Pontiac
HURRY SPRING SAVERS
66 VW Camper \$1,995
73 Charger SE, loaded \$1,495
73 Chevy Newport, air \$2,295
73 Ford Pickup, auto \$2,295
74 Dusters, 3 from \$2,295
74 Ply. Satellite, V8 \$2,995
71 VW Bus, air \$1,995

FEISTER CHRYSLER-PLYMOUTH
37401 Ford Rd. at Newburgh
721-2400
FURY III, 1969, 4 door, turtle top, power steering & brakes, excellent condition. \$750. Evenings. 537-9569

GRAND OPENING SPECIAL! 1974 Satellite Sebring Plus, 2 door hardtop, red with white vinyl top, 3 way power, AM-FM stereo, factory air, rally wheels, 11,000 miles. One owner. MUST SEE TO BELIEVE!

ROLLIE BARRETT
30777 Plymouth Rd.
525-5000

GRAND PRIX 1974, air, AM-FM, power steering, power brakes, other extras. \$2,500. After 5 PM. 450-0211

CAR CLEARANCE
72 Ford Gd Torino, air \$1,384
72 Chry Newport, air \$1,989
71 Chry 300, pb, ps \$1,295
72 Duster, auto, power \$1,337
73 Buick 225, loaded, air \$2,774
71 Chry T & C wgn, air \$1,295
71 Dameron Chry-Ply G'd River at Middlebelt 476-7900

ROAD RUNNER 1969, 383 4 speed, AM-FM stereo 8 track, new tires, new shocks. Good condition. \$850 or best offer. 437-0408

880 Pontiac
TEMPEST 1967, 6 cylinder, power steering, power brakes, automatic, good condition, new tires. \$22,774

GRAND PRIX, 1971, air, automatic, power steering, power brakes. Excellent condition. \$1895. 328-4346

EXECUTIVE, 1967, 4 door, automatic, power steering & brakes. \$250. 477-5544

1968 FIREBIRD
6 cylinder, automatic transmission, power steering, radio, good tires. Real clean car. Asking
\$1,195
BOB SELLERS PONTIAC
LOW OVERHEAD EQUALS
LOW PRICES
22520 Grand River KES-7600

CATALINA, 1966 convertible, automatic, good running condition, 28223 Whitcomb, Livonia, 6 Mile & Harrison.
CATALINA, 1968, air power steering, power brakes, excellent condition. \$750. GA 5-6929

1973 CATALINA
2 door hardtop, AM-FM radio, factory air conditioning, power steering, power brakes, radial tires, low miles, asking
\$2,350
BOB SELLERS PONTIAC
LOW OVERHEAD EQUALS
LOW PRICES
22520 Grand River 532-8720

GRANDVILLE



# 1-STOP SHOPPING GUIDE

PRICES GOOD MONDAY APRIL 21 THRU SATURDAY APRIL 26, 1975.

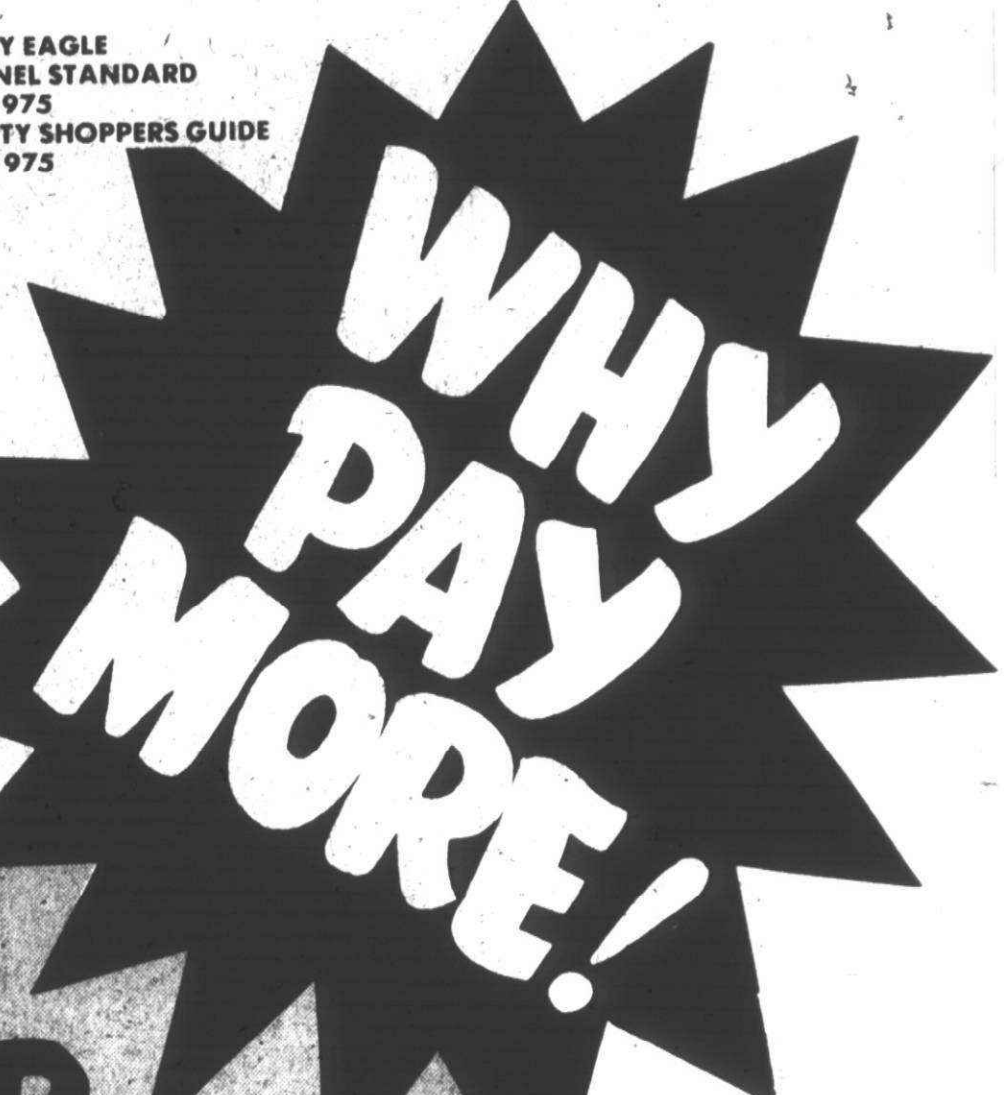

FINEST USDA CHOICE

MEIJER U.S.D.A. FINEST CHOICE AVAILABLE WITH SATISFACTION GUARANTEED OR DOUBLE YOUR MONEY BACK.

ECONOMY BEEF

MEIJER ECONOMY IS A LEAN YOUNG BEEF LOW IN FAT, CHOLESTEROL, AND WASTE. HIGH IN PROTEIN. IDEAL FOR THE BUDGET MINDED.

ECONOMY BEEF

## RIB STEAKS

**\$1.08**  
lb.



## SIRLOIN STEAK \$1.18

ECONOMY BEEF

ECONOMY BEEF

LEAN BEEF

## SHORT RIBS... 58¢

ECONOMY BEEF

ARM POT ROAST

88¢

ECONOMY BEEF

BONELESS BRISKET OF BEEF

98¢

ECONOMY BEEF

T-BONE STEAK

\$1.38

ECONOMY BEEF

BLADE CHUCK ROAST

68¢

ECONOMY BEEF

BONELESS TIP OR PORTERHOUSE STEAK

\$1.48

ECONOMY BEEF

BONELESS STEW BEEF

98¢

ECONOMY BEEF

BONELESS ROLLED RUMP ROAST

\$1.38

ECONOMY BEEF

CUBE STEAK

\$1.18

ECONOMY BEEF

GUARANTEED ○ Top Fresh GUARANTEED ○ Top Fresh GUARANTEED ○ Top Fresh GUARANTEED ○ Top Fresh GUARANTEED ○

ONE OF THE BEST ALL-PURPOSE APPLES

U.S. FANCY MICHIGAN FLAVORBEST MCINTOSH

APPLES 3 LB. BAG 47¢

LOW IN CALORIES - HIGH IN FLAVOR TENDER FRESH

ASPARAGUS 47¢ lb.

GOURMET'S DELIGHT FRESH - MOONLIGHT MUSHROOMS

67¢

FANCY CALIFORNIA - GREEN GLOBE ARTICHOKES

2/39¢

MEIJER

• WELCOMES U.S.D.A. GOVERNMENT FOOD STAMPS  
• RESERVES THE RIGHT TO LIMIT TO REASONABLE QUANTITIES

in the News 'n Views Department

CHARGE IT TODAY, THE MEIJER WAY

THE MEIJER CHARGE PLAN is our new method of Revolving Charge for making installment payments on large purchases. This plan is available at all Thrifty Acres, where merchandise except for Grocery, Pharmacy, Party Store, and personal jewelry items may be charged. The minimum charge amount is \$100.00 but this may be an accumulation of several items.

FOR INDIVIDUALS who have one of six approved and unexpired credit cards, a Michigan Driver's License, and a telephone, we can approve first purchase "Instant Credit" up to \$500. If you don't qualify for "Instant Credit", or your purchase exceeds \$500, we'll need to call for approval. While some approvals may take up to three days to obtain, many are obtained the same day. We'll call you when approval is obtained so that you may come in and complete the purchase. The company handling our charge accounts is General Electric Credit Corporation (GECC). All payments on the Meijer Charge Plan are made quickly and conveniently through the mail.

AFTER THE INITIAL PURCHASE, an I.D. card will be mailed to you. Future purchases over \$100 and within available credit can then be made without further approval.

THE MEIJER CHARGE PLAN is one more added service for you. Master Charge and Bank Americard will continue to be used at any register in our Thrifty Acres as in the past. Master Charge and Bank Americard may also be used in Meijer Supermarkets for Home Center items. Use either of these bank cards or use our new MEIJER CHARGE PLAN. Ask the clerk, in the department where you find an item you'd like to charge, for details of the plan.

THE MEIJER CHARGE PLAN is one more reason to visit Meijer...you're one-stop-shopping store.



Why Pay More! Why Pay More! Why Pay More! Why Pay More! Why Pay More! Why Pay More! Why Pay More!



**MEIJER**  
thrifty acres  
AND  
SUPER MARKETS

**PARKAY**  
**MARGARINE** 39¢  
16 oz. wt. pkg. (quarters)

**PAPERMAID**  
**BAKING CUPS** 10¢  
88 count pkg.

**WHY PAY MORE!**  
FLEISCHMANN  
SOFT DIET  
MARGARINE  
59¢

**KRAFT HUT SWISS**  
CHEEZ WHIZ ..... 8 oz. wt. jar 49¢  
**FLORIDA**  
CITRUS BLEND ..... 8 fl. oz. bt. 10¢  
FOOD CLUB ORANGE OR CINNAMON  
DANISH ROLLS ..... 9-1/2 oz. wt. tub 2/85¢  
FOOD CLUB SHREDDED CHEDDAR OR  
PIZZA CHEESE ..... 4 oz. wt. pkg. 3/1¢  
LIGHTLY SALTED  
LAND O LAKES BUTTER ..... 16 oz. wt. pkg. 79¢  
AZTECA  
SOFT TACO KITS ..... 8-1/2 oz. wt. pkg. 47¢

**WHY PAY MORE!**  
**TOP FROST**  
**FROZEN GRAPE**  
**JUICE** 48¢  
12 fl. oz. can

**APRIL HILL FROZEN**  
BREAD DOUGH ..... 32 oz. wt. pkg. 44¢  
SALUTO FROZEN  
PARTY PIZZA ..... 32 oz. wt. pkg. \$2.27  
MRS. PAUL'S FROZEN  
FISH STICKS ..... 14 oz. wt. pkg. 88¢  
SARA LEE FROZEN RASPBERRY OR ALMOND  
COFFEE RING ..... 9-1/2 to 9-3/4 oz. wt. pkg. 98¢  
SWANSON FROZEN  
POT PIES ..... 8 oz. wt. pkg. 3/1¢  
ELGIN FROZEN  
FLAV 'R WHIP ..... 9 oz. wt. ct. 43¢

**WHY PAY MORE!**  
FRESH  
FROZEN  
VEGETABLES  
55¢

**Why Pay More!**  
**WHY PAY MORE!**  
**COLLEGE INN**  
**BEEF BROTH** 19¢  
13-3/4 fl. oz. can

**MEIJER HOTDOG OR**  
HAMBURG BUNS ..... pkg. of 8 3/99¢  
SCHAFFER  
CORN MEAL BREAD ..... 16 oz. wt. loaf 49¢  
DEEP SEA RED  
SOCKEYE SALMON ..... 3-3/4 oz. wt. can 69¢  
GOOD SEASONS NEW!  
RANCH DRESSING MIX ..... 1-1/2 oz. wt. pkg. 39¢  
DUNCAN HINES BLUEBERRY  
MUFFIN MIX ..... 13 oz. wt. box 69¢  
PURINA  
DOG CHOW ..... 25 lb. bag \$5.14

**WHY PAY MORE!**  
SMUCKER  
STRAWBERRY  
PRESERVES  
77¢

**AEROSOL WINDOW CLEANER - 10¢ off label**  
AJAX ..... 15 oz. wt. can 45¢  
LIQUID DIET FOOD CHOCOLATE 4 VARIETIES  
CARNATION SLENDER ..... 10 fl. oz. can 29¢  
JIF CREAMY OR CRUNCHY  
PEANUT BUTTER ..... 28 oz. wt. jar \$1.27  
LIPTON SPRING VEGETABLE  
CUP-A-SOUP ..... pkg. of 4 49¢  
LIPTON CHICKEN NOODLE WITH MEAT  
CUP-A-SOUP ..... 1-1/2 oz. wt. bar 49¢

**WHY PAY MORE!**  
**8 PACK REGULAR**  
**SEVEN UP** 16 fl. oz. NR btl. \$1.38  
**SUGAR FREE 8 PACK**  
**SEVEN-UP** 16 fl. oz. NR btl. \$1.28

**CRISCO OIL** 179¢  
**CHIEF-BOY-AR-DEE** 88¢  
40 oz. WT. CAN

**WHY PAY MORE!**  
ASSORTED TOWELS  
45¢

**LIPTON BEEF NOODLE**  
CUP-A-SOUP ..... 1-3/4 oz. wt. bar 49¢  
JENOS PEPPERONI  
PIZZA MIX ..... 29 oz. wt. bar \$1.23  
VAN CAMP  
PORK & BEANS ..... 53 oz. wt. can 89¢  
HUNT'S  
TOMATOES ..... 28 oz. wt. can 49¢  
FOOD CLUB INSTANT GRAPE  
BREAKFAST DRINK ..... 18 oz. wt. jar \$1.19

**WHY PAY MORE!**  
**TOPCO**  
**PLASTIC**  
**WRAP** 39¢  
200 foot roll

**STOKELY**  
GATORADE ..... 32 fl. oz. (qt.) bt. 46¢  
WASH 'N DRI  
TOWELETTES ..... 22 count bar 65¢  
TIDY HOME  
LUNCH BAGS ..... 50 ct. pkg. 31¢  
ROBIN HOOD WHOLE WHEAT OR  
GRAHAM FLOUR ..... 5 lb. wt. bag 97¢  
PILLSBURY LIQUID  
SWEET 10 ..... 6 fl. oz. bt. 79¢

**WHY PAY MORE!**  
SPARKLE  
GLASS CLEANER  
WITH SPRAYER  
43¢

**SYLVANIA LIGHT BULBS** 89¢  
PKG. OF 2

**WHY PAY MORE!**  
Beef, Chicken & Liver  
Gourmet, Turkey & Bacon  
**MIGHTY DOG**  
**DOG FOOD** 19¢  
6-1/2 oz. wt. can

**HERSHEY**  
CHOCOLATE SYRUP ..... 16 oz. wt. can 38¢  
WELCH  
GRAPE JELLY ..... 10 oz. wt. tumbler 59¢  
STEAK SUPREME  
STEAK SAUCE ..... 5 oz. wt. bt. 48¢  
KRAFT  
CATALINA DRESSING ..... 8 fl. oz. bt. 55¢  
KRAFT  
1000 ISLAND DRESSING ..... 8 fl. oz. bt. 49¢

**WHY PAY MORE!**  
LESTON  
89¢

**KRAFT**  
ROKA DRESSING ..... 8 fl. oz. bt. 59¢  
KRAFT MIRACLE WHIP  
SALAD DRESSING ..... 32 fl. oz. (qt.) jar 97¢  
KRAFT MIRACLE WHIP  
SALAD DRESSING ..... 48 fl. oz. jar \$1.39  
LIPTON BEAN  
CUP-A-SOUP ..... 4 oz. wt. bar 49¢  
HEINZ KOSHER  
DILL GHERKINS ..... 16 fl. oz. jar 85¢

**WHY PAY MORE!**  
**PRE-SOAKIN**  
**AXION**  
**LAUNDRY** \$1.19  
38 oz. wt. bar

**STAYGREEN** 49¢

<p><b>20¢ COUPON</b> SAVE 20¢ with this coupon toward the purchase of: <b>AUTOMATIC DISH DETERGENT</b> <b>ELECTRASOL</b> 99¢ 50 oz. wt. bar Good Mon., Apr. 21 thru Sat., Apr. 26, 1975 OWN</p>	<p><b>12¢ COUPON</b> SAVE 12¢ with this coupon toward the purchase of: <b>BATH SOAP</b> <b>DOVE</b> 57¢ 7 oz. wt. bar, 9-1/2 oz. wt. pkg. Good Mon., Apr. 21 thru Sat., Apr. 26, 1975 OWN</p>	<p><b>10¢ COUPON</b> SAVE 10¢ with this coupon toward the purchase of: <b>DOW</b> <b>HANDI-WRAP</b> 33¢ 100 ft. roll Good Mon., Apr. 21 thru Sat., Apr. 26, 1975 OWN</p>	<p><b>10¢ COUPON</b> SAVE 10¢ with this coupon toward the purchase of: <b>SIMPLE 'N DELICIOUS'</b> <b>BREAD MIXES</b> White, Whole Wheat &amp; Rye 79¢ 22-3/4 oz. wt. bar Good Mon., Apr. 21 thru Sat., Apr. 26, 1975 OWN</p>	<p><b>15¢ COUPON</b> SAVE 15¢ with this coupon toward the purchase of: <b>NATURAL PLAIN</b> <b>HEARTLAND CEREAL</b> 15¢ OFF 16 oz. wt. bar Good Mon., Apr. 21 thru Sat., Apr. 26, 1975 OWN</p>
-----------------------------------------------------------------------------------------------------------------------------------------------------------------------------------------------------------------------------	---------------------------------------------------------------------------------------------------------------------------------------------------------------------------------------------------------------------------	------------------------------------------------------------------------------------------------------------------------------------------------------------------------------------------------------	-----------------------------------------------------------------------------------------------------------------------------------------------------------------------------------------------------------------------------------------------------------	----------------------------------------------------------------------------------------------------------------------------------------------------------------------------------------------------------------------------

**MEIJER THRIFTY ACRES — 45001 FORD RD. AT CANTON CENTER RD.**  
SHOP MONDAY THRU SATURDAY 8 A.M. TO 10:30 P.M. — SUNDAY 9 A.M. TO 7 P.M.

Why Pay More! Why Pay More! Why Pay More! Why Pay More! Why Pay More! Why Pay More! Why



**Food Club** VERY YOUNG UNGRADED  
**SWEET PEAS** 17 OZ. WT. CAN  
 CUT OR FRENCH STYLE  
**GREEN BEANS** 16 OZ. NET WT.  
**4/99¢**

**Food Club** **FRUIT COCKTAIL** 17 oz. wt. can  
**3/\$1.00**

**Food Club** 16 oz. wt. can  
**SLICED BEETS** **4/99¢**

**Food Club** 16 oz. wt. can  
**APPLESAUCE** **4/\$1**

**WHY PAY MORE!**  
**WEST BAY CUT ASPARAGUS**  
 14-1/2 oz. wt. can  
**29¢**

**WHY PAY MORE!**  
**VAN CAMP NEW ORLEANS STYLE KIDNEY BEANS**  
 15 oz. wt. can  
**3/79¢**

**Food Club**  
**INSTANT ORANGE BREAKFAST DRINK**  
 27 oz. wt. jar  
**\$1.29**

**Food Club**  
**APPLE JUICE**  
 46 fl. oz. can  
**2/95¢**

**Food Club**  
**SLICED CARROTS**  
 16 oz. wt. can  
**5/99¢**

**MRS. TUCKER PRECREAMED SHORTENING** 42 FL. OZ. WT. CAN **98¢** **Why Pay More!**

**WHY PAY MORE!**  
**CREAMETTE WIDE EGG NOODLES OR EXTRA WIDE NOODLES**  
 16 oz. (1 lb.) wt. bag  
**47¢**

**WHY PAY MORE!**  
**HUNGRY JACK INSTANT MASHED POTATOES**  
 32 oz. wt. (2 lb.) bag  
**99¢**

**WHY PAY MORE!**  
**KELLOGG SUGAR FROSTED MINI-WHEATS**  
 12 oz. wt. box  
**59¢**

**WHY PAY MORE!**  
**3 VARIETIES BETTY CROCKER TUNA HELPERS**  
 8-8.75 oz. wt. box  
**59¢**

**WHY PAY MORE!**  
**DUNCAN HINES BROWNIE MIX**  
 23 oz. wt. bag  
**89¢**

**FOOD CLUB 5 VARIETIES**  
**CHIPPED MEATS** 3 oz. **39¢** pkg.

**FOOD CLUB CHUNK**  
**BRAUNSCHWEIGER** **39¢** lb.

**HERRUD WHOLE**  
**RING BOLOGNA** **69¢** lb.

**HERRUD PORK**  
**LINK SAUSAGE** **79¢** pkg.

**KENT POLISH AND**  
**SMOKED SAUSAGE** **79¢** lb.

**PETERS**  
**SKINLESS FRANKS** **59¢** lb.

**OSCAR MAYER, CLAUSSEN KOSHER AND**  
**ICICLE PICKLES** **79¢** qt.

**VANDENBRINK**  
**HAM FLAVORED LOAF** 2 lbs. **\$1.89** pkg.

**ARMOUR**  
**CORN DOGS** **89¢** lb.

**HERRUD 20 OUNCE FAMILY PACK SLICED**  
**BOLOGNA-SALAMI-COMBINATION** **\$1.29** pkg.

**ARMOUR STAR** 12 oz. pkg.  
**SLICED BACON** **98¢** pkg.

**ARMOUR BREADED VEAL PATTIES OR**  
**DRUMSTICKS** 12 oz. pkg. **89¢** pkg.

**COLE'S BAKERY**  
 REG. 11.09 - 14 oz.  
**DANISH STRAWBERRY JAM COFFEE CAKE** **99¢**  
 Pkg. of 8  
**HAMBURG/HOT DOG BUNS** **2/1**

**10¢ COUPON** SAVE 10¢ with this coupon toward the purchase of:  
**KRETSCHNER SUGAR & HONEY**  
**WHEAT GERM** **10¢ OFF** WITH COUPON  
 Good Mon. Apr. 21 thru Sat. Apr. 26, 1975  
**MEIJER THRIFTY ACRES & SUPER MARKETS** 418

**MEIJER** thrifty acres **La Mesa stoneware**

**THIS WEEK'S FEATURE**  
**BREAD & BUTTER Only** **29¢ EACH** **Why Pay More!**

**5-YEAR OPEN STOCK GUARANTEE** PLUS COMPLETER PIECES TO COMPLEMENT YOUR SET...

**DISHWASHER SAFE! FROM OVEN TO TABLE!**

WITH EVERY \$30.00 PURCHASE excluding alcoholic beverages and tobacco products

2 SOUP BOWLS	\$2.99	12" ROUND PLATTER	\$4.99
2 SALAD PLATES	\$2.99	9" ROUND BOWL	\$2.99
2 CEREAL BOWLS	\$2.99	COFFEE SERVER	\$7.99
GRAVY BOAT W/STAND	\$4.99	SALT & PEPPER	\$2.99
COVERED SUGAR BOWL	\$2.99	COVERED CASSEOLE	\$9.99
CREAMER	\$2.99	COVERED BUTTER DISH	\$3.99

PRICES GOOD MONDAY APRIL 21 THRU SATURDAY APRIL 26, 1975. MEIJER RESERVES THE RIGHT TO LIMIT SALES ACCORDING TO SPECIFIED LIMITS. NO SALES TO DEALERS, INSTITUTIONS OR DISTRIBUTORS.

**MEIJER** • WELCOMES U.S.D.A. GOVERNMENT FOOD STAMPS • RESERVES THE RIGHT TO LIMIT TO REASONABLE QUANTITIES

Why Pay More! Why Pay More! Why Pay More! Why Pay More! Why Pay More! Why Pay More!



in the Men's and Boys' Dept...

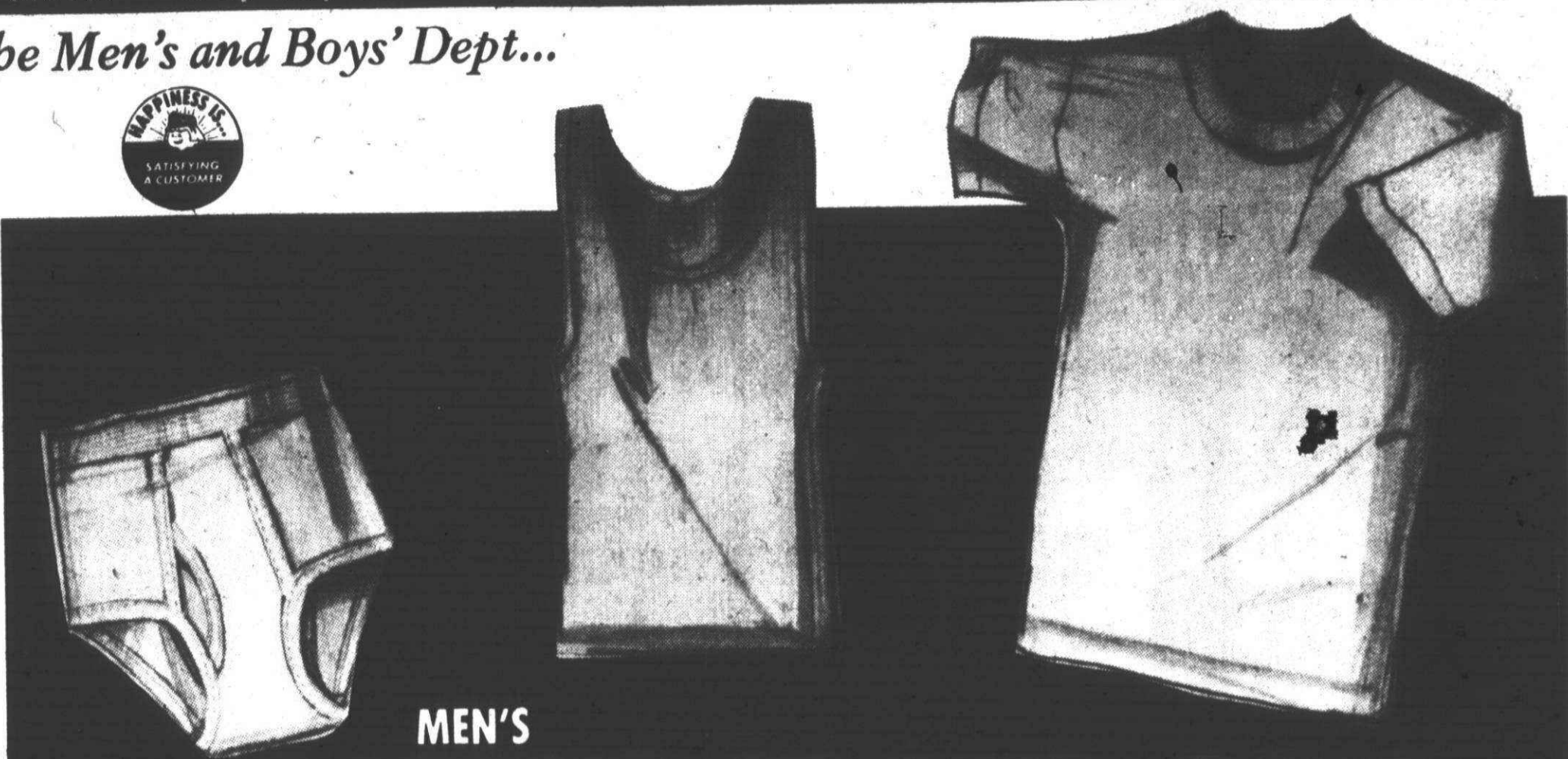

MEN'S

# FAMOUS BRAND SALE!

**MEN'S T-SHIRTS & BRIEFS — ATHLETIC SHIRTS**  
Slight irregulars of our largest selling style of underwear. Imperfections do not affect the wearability. Men's sizes. Not all sizes available in all stores.

PKG. OF TWO **\$1.50**



## MEN'S CUT OFFS

Fringed bottom with western styling. Sizes 29 to 36.

**\$3.96** pr.

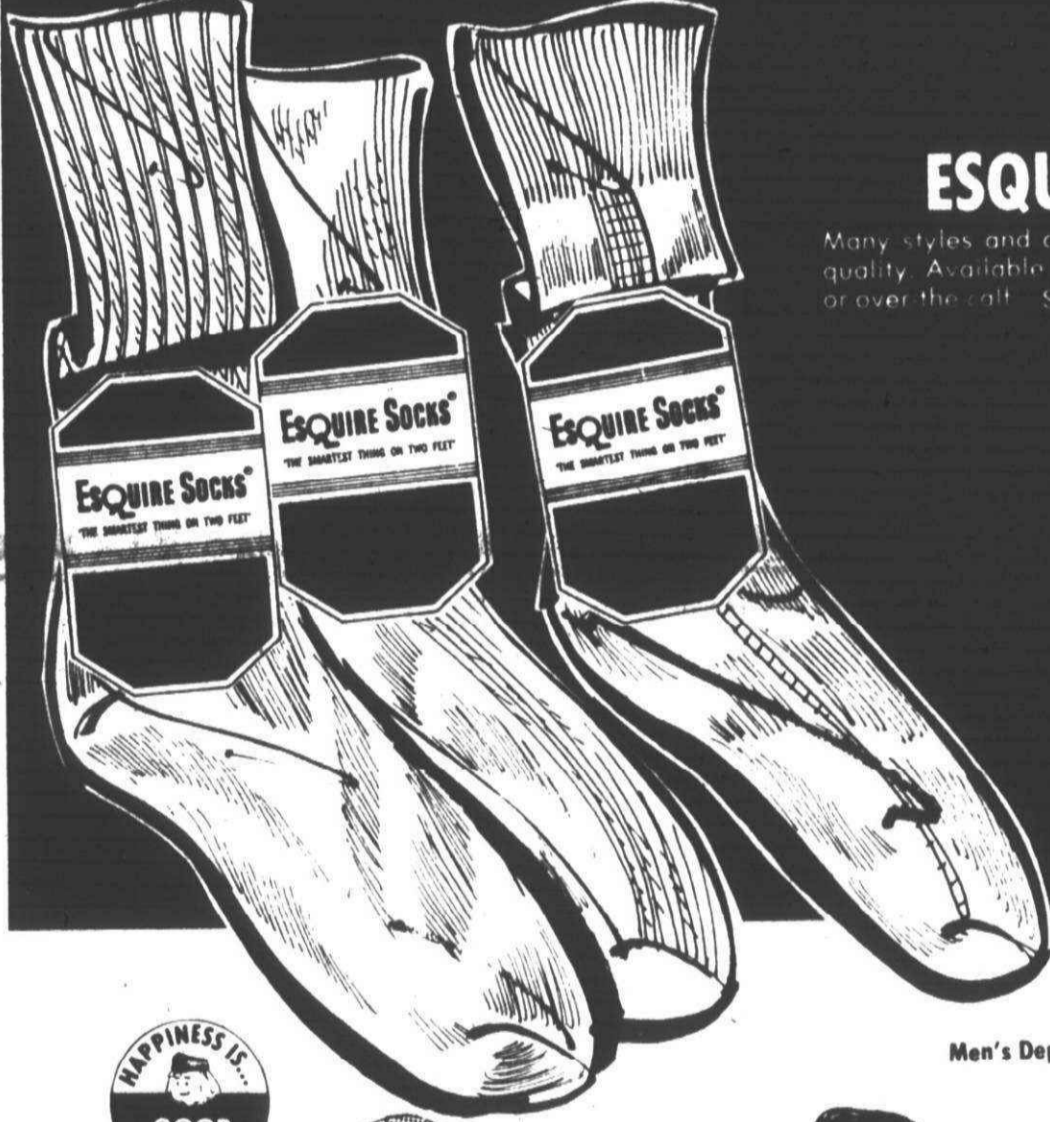

## MEN'S ESQUIRE SOCKS®

Many styles and colors of this famous sock. All first quality. Available in nylon or cotton in solids, fancies or over the calf. Sold in specialty shops at \$1.50 to \$2.50.

**89¢** pr.



Men's Dept.

## BOYS' DENIM JACKETS

Available in Western style with snap front, 50% cotton and 50% polyester for extra wearability. Sizes 8-18.

**\$6.50** ea.

Boys' Dept.

## BOYS' DENIM JEANS

10 oz. denim. 100% cotton for extra comfort. Available in two styles. Sizes 8 to 18.

**\$4.50** pr.

Boys' Dept.



## BOYS' TANK TOPS

New heather solid colors. Sizes S-M-L.

**\$1.60** ea.



## MEN'S MOJAVE® KNIT SHIRTS

Men's striped knit shirts in the most popular casual style. 50% polyester/50% cotton for easy care. Sizes S-M-L-XL.

OUR REG. \$3.96  
**\$2.96** ea.

## MEN'S SWIM WEAR

A large group of solid and fancy swimwear. Sizes S-M-L-XL.

**\$2.77** ea.

## MEN'S SWEATSHIRTS

Solids color short sleeve sweatshirts with contrast trim, very sharp style. Sizes S-M-L-XL.

**\$2.27** ea.



Why Pay More!

Why Pay More! Why Pay More! Why Pay More! Why Pay More! Why Pay More! Why Pay More!

PRICES GOOD MONDAY APRIL 21 THRU SATURDAY APRIL 26, 1975.

MEIJER RESERVES THE RIGHT TO LIMIT SALES ACCORDING TO SPECIFIED LIMITS.

NO SALES TO DEALERS, INSTITUTIONS OR DISTRIBUTORS.

CHARGE ANYTHING IN THE STORE EXCEPT FOOD, LIQUOR AND SUPERMARKET ITEMS



YOU DON'T NEED CASH! USE EITHER OF THESE CONVENIENT CREDIT CARDS!



Why Pay More! Why Pay More! Why Pay More! Why Pay More! Why Pay More! Why Pay More!

# "Sportsweat Spectacular Sale"

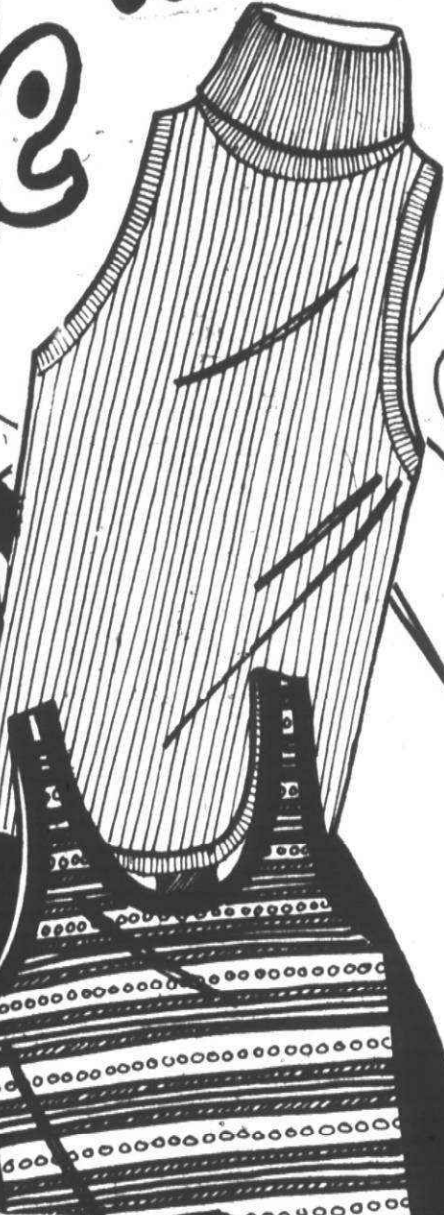

Special purchase of ladies tops, tanks, T-shirts, crop tops, placket front pull overs. Available in assorted solids, prints and stripes. Sizes S-M-L.

Why Pay More!

**2<sup>33</sup>**  
ea.

Ladies' Dept.

**SPECIAL PURCHASE!**  
**LADIES' POLYESTER PANTSETS**

Checks, dots and solid combinations in "Now thru Summer" colors. Sizes 10-20.



**\$9<sup>87</sup>**  
set

WHILE QUANTITIES LAST!

Ladies' Dept.

Why Pay More!

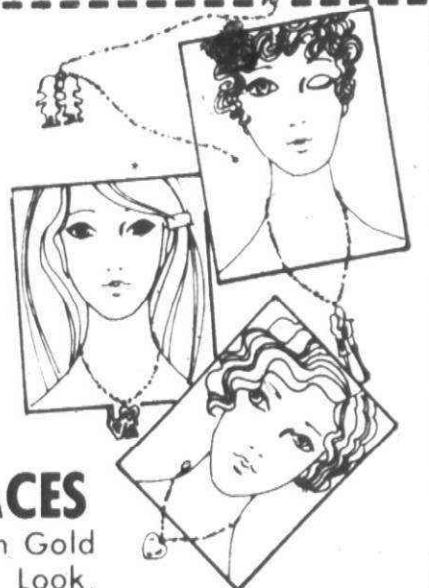

**LADIES' NECKLACES**

Choose from Gold and Silver Look, Kissin' Cousins, Love, Mother of Pearl Heart, and many other styles.

**\$1<sup>67</sup>**  
ea.

Jewelry Dept.



Why Pay More!

**LADIES' VINYL RAIN COATS WITH VINYL HEAD SCARF**

Sizes small, medium and large.

SAVE 67¢

OUR REG. \$2.34

**\$1<sup>67</sup>**  
ea.

Ladies' Dept.



**LADIES' SHIFT GOWNS**

Nylon with assorted trims in spring fashion colors. Sizes S-M-L.

Why Pay More!

**\$3<sup>37</sup>**  
ea.

Ladies' Dept.



**LADIES' ALL SHEER PANTY HOSE**

Sheer from toe to waist. Assorted natural shades. Available in one size.

**3 PR. FOR \$1<sup>00</sup>**

Ladies' Dept.

PRICES GOOD MONDAY APRIL 21 THRU SATURDAY APRIL 26, 1975.

MEIJER RESERVES THE RIGHT TO LIMIT SALES ACCORDING TO SPECIFIED LIMITS.

NO SALES TO DEALERS, INSTITUTIONS OR DISTRIBUTORS.

CHARGE ANYTHING IN THE STORE EXCEPT FOOD, LIQUOR AND SUPERMARKET ITEMS



**YOU DON'T NEED CASH! USE EITHER OF THESE CONVENIENT CREDIT CARDS!**



Why Pay More! Why Pay More! Why Pay More! Why Pay More! Why Pay More! Why Pay More!

Why Pay More! Why Pay More! Why Pay More! Why Pay More! Why Pay More! Why Pay More!



thrifty acres

# COSCO BABY FURNITURE AND ACCESSORIES

Why Pay More!

## COSCO® DIAPER PAIL

20 quart capacity. Floral decal on lid. Built-in deodorizer receptacle.

SAVE \$1.53  
OUR REG. \$4.97

**\$3.44** ea.

Infants' Dept.



GOOD SERVICE!



## COSCO® GO SEAT

High impact, contour-molded seat. Adjusts to 3" and 6" heights. Built-in vinyl covered foam pad. Chrome legs with skid-resistant, non-marring pads.

OUR REG. \$8.97

**\$7.44** ea.

SAVE \$1.53

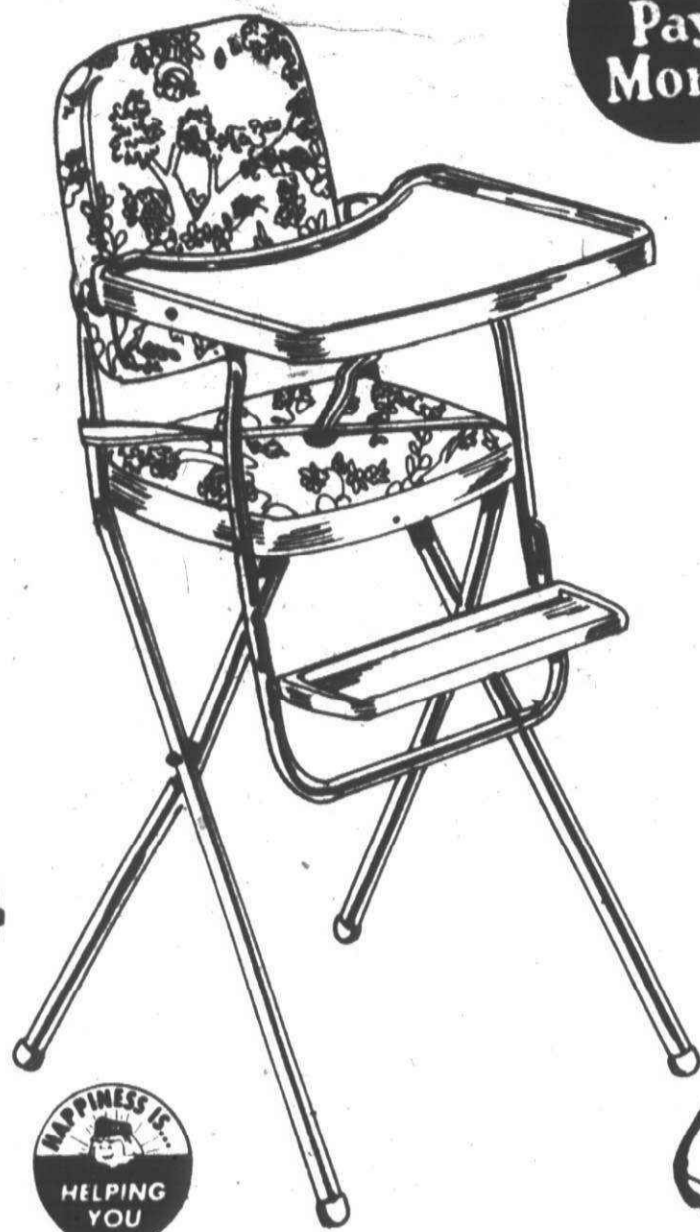

## COSCO® HIGH CHAIR

Chrome frame, safety locking device under seat. Adjustable, high-impact, molded tray. Easy-clean, vinyl upholstery in the "Sprite" pattern.

OUR REG. \$18.97

**\$15.44** ea.

SAVE \$3.53

## COSCO® LIL' LOUNGER BABY CARRIER

Heavy duty molded shell. Adjusts to three positions. Easy-clean, vinyl covered, quilted foam pad in the "Sprite" pattern.

OUR REG. \$6.97

**\$5.44** ea.

SAVE \$1.53

## COSCO® BABY JUMPER

Tubular chrome steel suspension safety frame. Enameled steel tray. Nylon reinforced, easy-clean, vinyl seat in the "Sprite" pattern.

OUR REG. \$12.97

**\$9.94** ea.

SAVE \$3.03

## COSCO® TRAINING SEAT

New concept in training seats. Tough, high-impact polystyrene. Round base for extra stability.

AFTER AD \$4.97

**\$3.94** ea.

save \$1.03

Infants' Dept.

Infants' Dept.

Infants' Dept.

Infants' Dept.

**COUPON** SAVE \$2.00 with this coupon toward the purchase of: **YOUTH'S MIGHTY MATES** \$8.94 OUR REG. \$10.94 SIZES 8 1/2 to 3 WITH COUPON GOOD Mon. Apr. 21 thru Sat. Apr. 26, 1975

Meijer THRIFTY ACRES 920

**COUPON** SAVE \$2.00 with this coupon toward the purchase of: **BOYS' MIGHTY MATES** \$9.94 pr. SIZES 3 1/2-7. OUR REG. \$11.94 WITH COUPON GOOD Mon. Apr. 21 thru Sat. Apr. 26, 1975

Meijer THRIFTY ACRES 970

**COUPON** SAVE \$2.00 with this coupon toward the purchase of: **GIRLS' MISSY MATES** \$7.47 pr. SIZES 8 1/2-3. OUR REG. \$9.47 pr. WITH COUPON GOOD Mon. Apr. 21 thru Sat. Apr. 26, 1975

Meijer THRIFTY ACRES 930

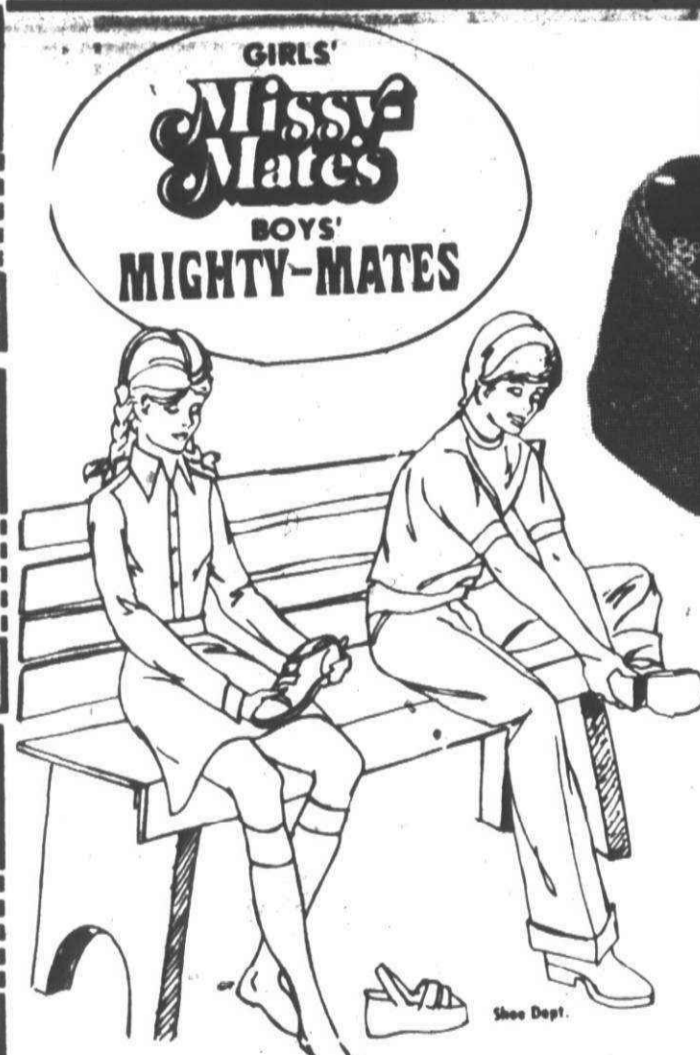

## GIRLS' MISSY MATES AND BOYS' MIGHTY-MATES

SAVE \$2 WITH COUPON



### Missy Mates "BUFFY"

Girls' Big Bottom wedge sandal. All over black or white patent or blue denim fabric with flower embroidery wedge, and blue or red bandanna fabric with burlap wedge. Sizes 8 1/2-3.

**\$7.47** pr. WITH COUPON



### MIGHTY-MATES "EDWARD"

Boys' two stripe sport Oxford. Available in white and navy combination smooth leather, or red suede and white smooth leather combination. Sizes 8 1/2-3. Also blue suede and white smooth leather combination. Sizes 8 1/2-3 3/2-7.

OUR REG. \$9.47 - MISSY MATES  
OUR REG. \$10.94-\$11.94 - MIGHTY MATES

**\$8.94 \$9.94** pr. and WITH COUPON



## BOYS' YOUTHS' & MEN'S LOW CUT AND HIGH CUT BASKETBALL SHOES

Heavy duck uppers with pull-proof eyelets. Available in black or white full cushion insoles. Men's sizes 6 1/2-13, Boy's sizes 2 1/2-6, and Youth's sizes 11-2.

OUR REG. \$4.96

**\$3.96** pr. WITH COUPON

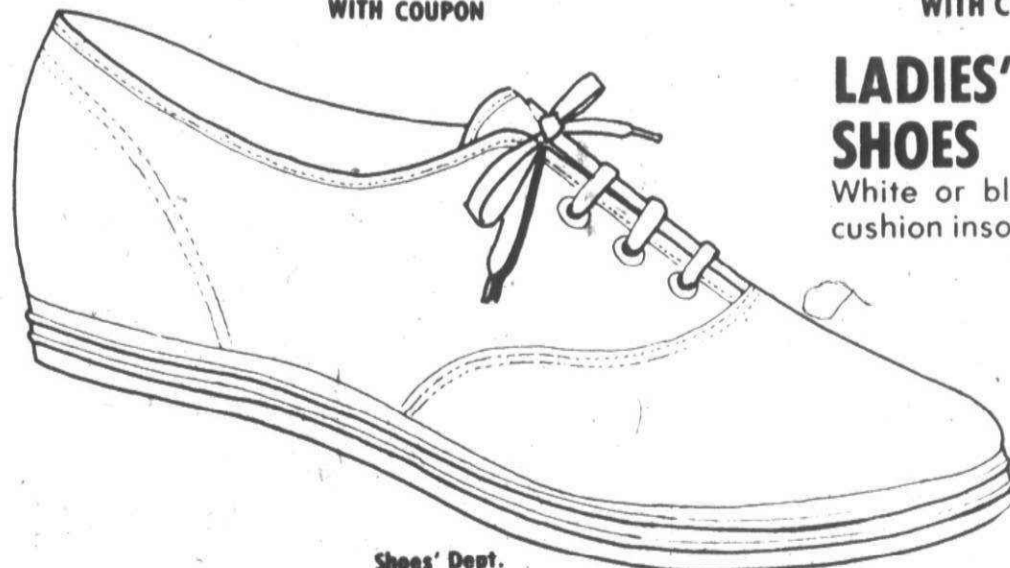

## LADIES' TENNIS SHOES

White or blue duck uppers. Full cushion insoles. Sizes 5 1/2 to 10.

OUR REG. \$3.46  
**\$2.46** pr. WITH COUPON

**COUPON** SAVE \$1.00 with this coupon toward the purchase of: **MEN'S BASKETBALL SHOES** OUR REG. \$4.96 \$3.96 pr. SIZES 6 1/2-13. LOW OR HIGH CUT WITH COUPON GOOD Mon. Apr. 21 thru Sat. Apr. 26, 1975

Meijer THRIFTY ACRES 900

**COUPON** SAVE \$1.00 with this coupon toward the purchase of: **BOYS' BASKETBALL SHOES** OUR REG. \$4.96 \$3.96 pr. HIGH OR LOW CUT. SIZES 2 1/2-6. WITH COUPON GOOD Mon. Apr. 21 thru Sat. Apr. 26, 1975

Meijer THRIFTY ACRES 901

**COUPON** SAVE \$1.00 with this coupon toward the purchase of: **YOUTHS' BASKETBALL SHOES** OUR REG. \$4.96 \$3.96 pr. HIGH OR LOW CUT SIZES 11-2. WITH COUPON GOOD Mon. Apr. 21 thru Sat. Apr. 26, 1975

Meijer THRIFTY ACRES 902

**COUPON** SAVE \$1.00 with this coupon toward the purchase of: **LADIES' TENNIS SHOES** OUR REG. \$3.46 \$2.46 pr. WITH COUPON GOOD Mon. Apr. 21 thru Sat. Apr. 26, 1975

Meijer THRIFTY ACRES 903

Why Pay More! Why Pay More! Why Pay More! Why Pay More! Why Pay More! Why Pay More!



thrifty acres

Why Pay More!

FREE



BRITANNICA JUNIOR ENCYCLOPEDIA



SATISFYING A CUSTOMER

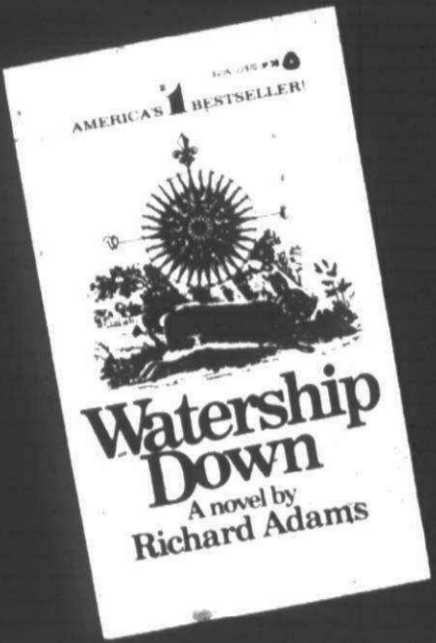

WATERSHIP DOWN  
PAPER BACK BOOK

\$1.88 ea.

Book Dept.

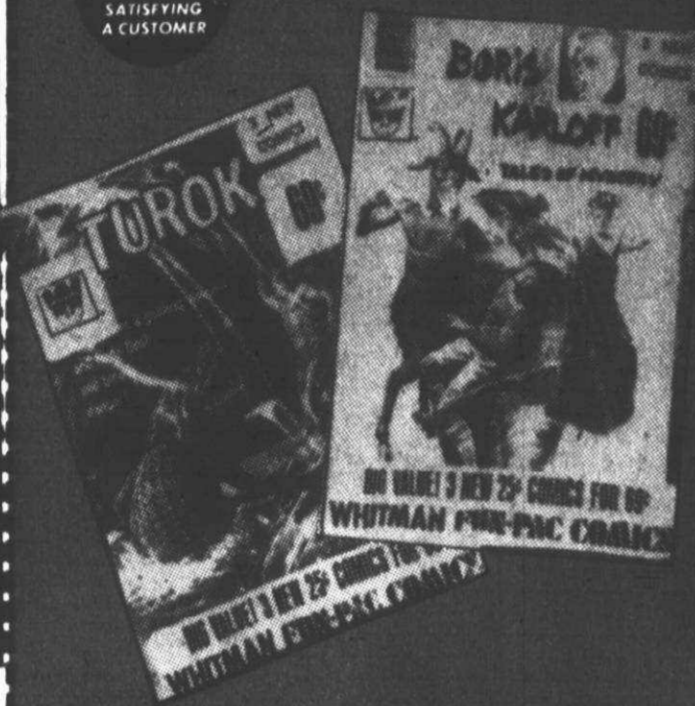

TUROK  
RAGGED COMIC BOOK

Why Pay More!

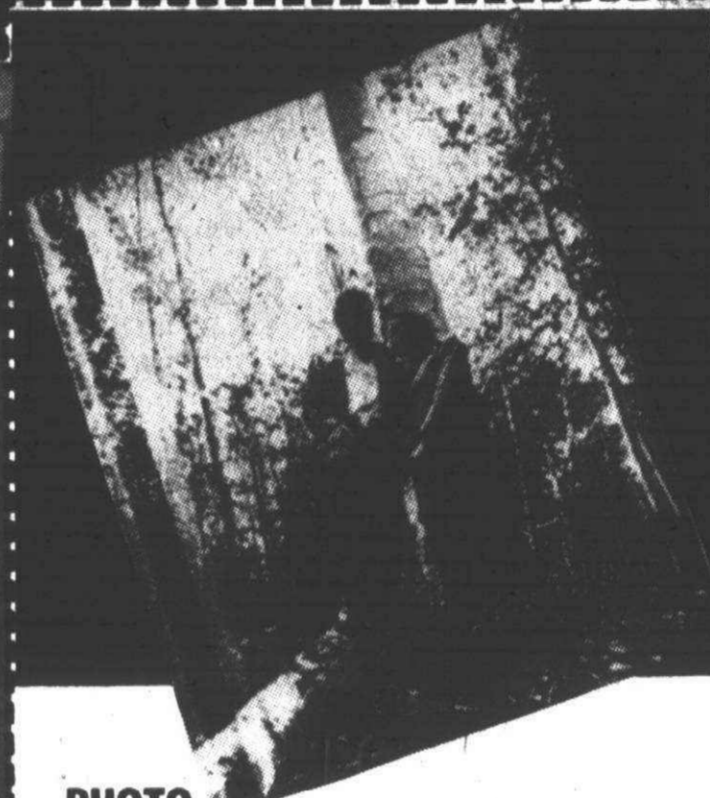
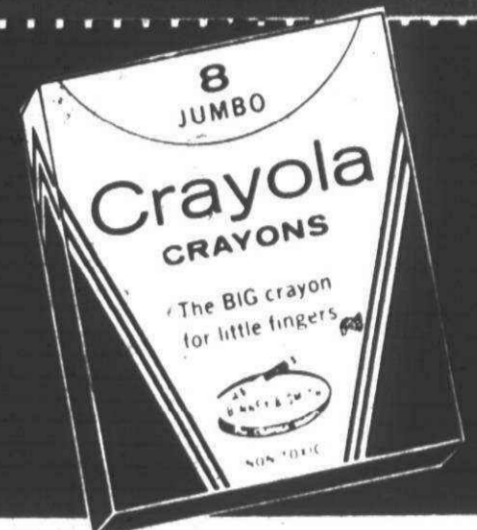

PHOTO ALBUM  
10 PAGE MAGNETIC COVERED RING

\$1.47 ea.

School Supplies Dept.



CRAYOLA JUMBO 8'S  
8 count box.

27¢ ea.

School Supplies Dept.

in the Health & Beauty Aids Dept

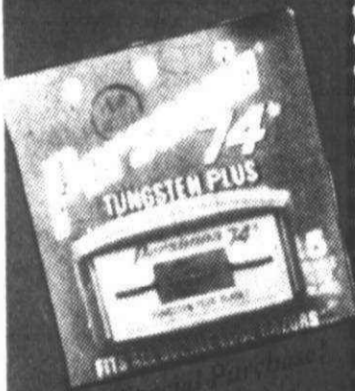

PERSONA DOUBLE EDGE RAZOR BLADES  
3 count package  
WHILE THEY LAST!  
4 FOR \$7.00



11 OZ. GILLETTE DRY LOOK HAIR SPRAY

99¢ ea.

Health and Beauty Aids Dept.



NEW SUPER DRY  
*Soft Dri*  
NON-STING ANTI-PERSPIRANT

58¢ ea.

NEW SUPER DRY ANTIPERSIRANT  
5 oz. net wt.

FOR TODAY'S MORE ACTIVE WOMEN

- STOPS WETNESS ALL DAY
- STOPS ODOR BETTER THAN THE LEADING DEODORANT SPRAY
- SPRAYS ON DRIER AND IT DOESN'T STAIN CLOTHING

Health and Beauty Aids Dept.



8 FL. OZ. BTL. TAME CREME RINSE

Special label package: Choice of Regular, With Body, Oily Lemon, or Balsam Conditioner.

48¢ ea.

Health and Beauty Aids Dept.



in the Pharmacy & Cosmetic Dept

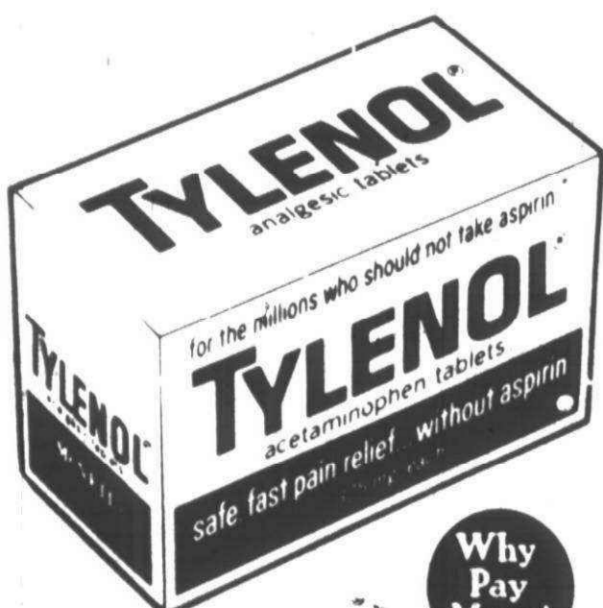

TYLENOL TABLETS  
100 count package.

Why Pay More!

\$1.41 pkg.



Pharmacy Dept.

PRICES GOOD MONDAY APRIL 21 THRU SATURDAY APRIL 26, 1975.

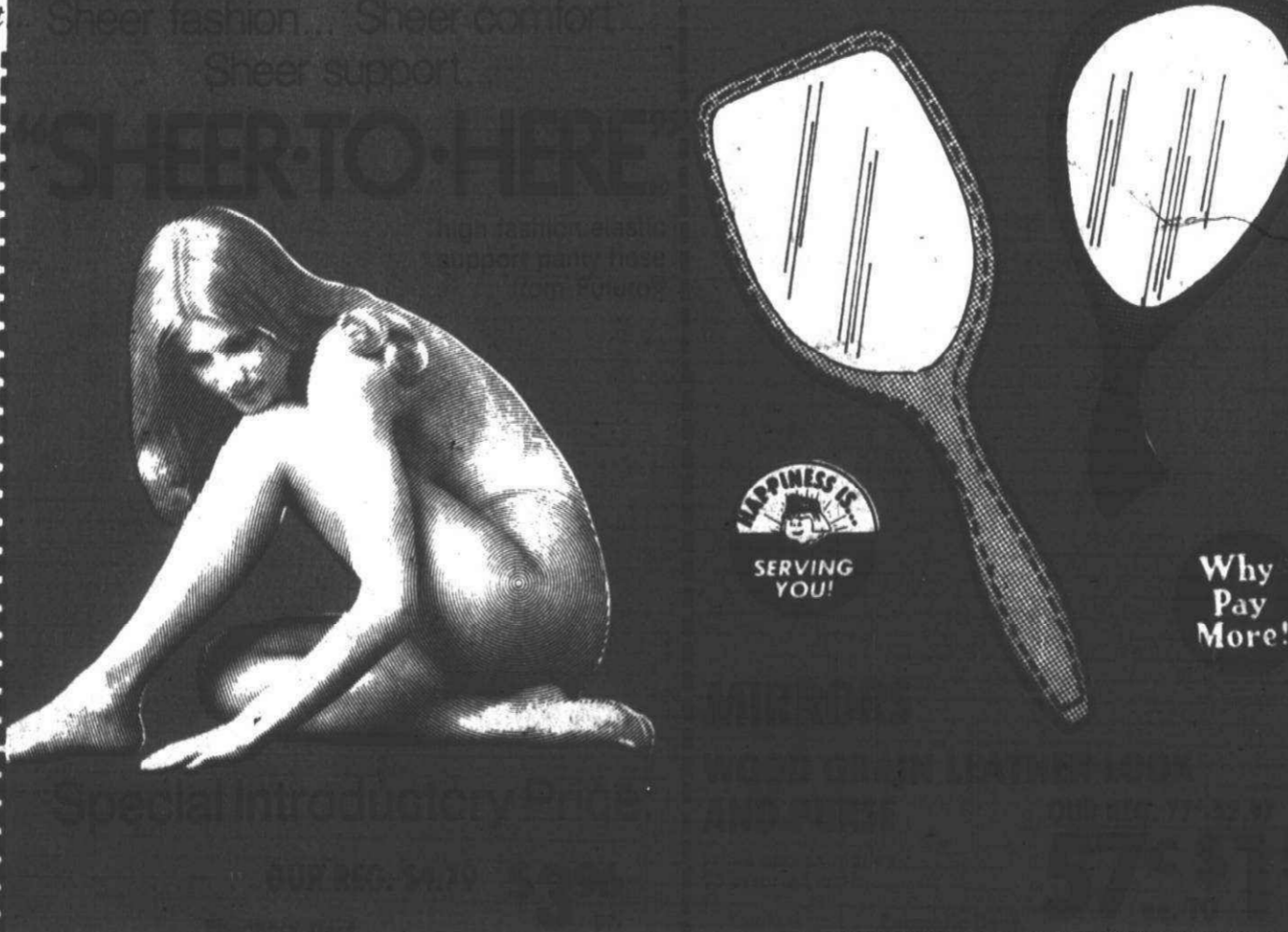

SERVING YOU!

Why Pay More!

SEBULEX DANDRUFF SHAMPOO

4 FL. OZ. OR 8 FL. OZ. LIQUID OR 4 OZ. CREAM SHAMPOO

25¢ OFF WITH COUPON

25¢ OFF WITH COUPON

SAVE 50¢ with this coupon toward the purchase of SEBULEX DANDRUFF SHAMPOO

4 fl. oz. or 8 fl. oz. liquid or 4 oz. net wt. cream

25¢ OFF WITH COUPON

Good Monday, April 21 thru Saturday, April 26, 1975

Meijer THRIFTY ACRES

Pharmacy Dept.

MEIJER RESERVES THE RIGHT TO LIMIT SALES ACCORDING TO SPECIFIED LIMITS. NO SALES TO DEALERS, INSTITUTIONS OR DISTRIBUTORS.

Page 7



YOU DON'T NEED CASH! USE EITHER OF THESE CONVENIENT CREDIT CARDS!



**m**

**MEIJER**

thrifty acres

Why Pay More!

# CANNING



## PORCELAIN ENAMELWARE CANNING EQUIPMENT

FOOD BLANCHER REG. \$5.97 (LIQUID CAPACITY, 7 QTS. 4 OZ.) **\$4.97** ea.

PRESERVING KETTLE REG. \$3.97 (LIQUID CAPACITY 16 QTS.) **\$2.97** ea.

7 JAR CANNER WITH RACK (LIQUID CAPACITY 21 QT. 16 OZ.) REG. \$5.97 **\$4.97** ea.



## 16 QUART MIRRO-MATIC SPEED COOKER-CANNER

It holds up to 7 qt. jars. Heavy duty polished aluminum. Features include: Mirro-Matic's indestructible pressure controls for 5, 10 or 15 lbs. settings that never need adjusting. Removable self-sealing gasket, dependable safety fuse. Food tray and Recipe instruction book included. Model M0406.

Save \$5.00  
OUR REG. \$39.87 **\$34.87** ea.

Why Pay More!

Housewares Dept.



## COVERED SAUCE POTS

Cover fits recess in pan to help prevent boiling over. Brilliant polished finish, inside sunray, satin finish, quick heat bottom. Heatproof plastic knobs. Cast aluminum handles. Graduated for easy measuring.



8 QT. SIZE **\$2.77** ea. 10 QT. SIZE **\$3.57** ea. 16 QT. SIZE **\$4.77** ea.



1 CUP MEASURE REG. 37¢

**27¢** ea.



1 PINT DIPPER REG. 63¢

**47¢** ea.



9 OZ. FRUIT JAR FUNNEL REG. 47¢

**37¢** ea.

## SMALLWARE

Made of safe, sanitary aluminum. Handy helpers at canning time. Choose from:

GET READY NOW!  
CANNING SEASON "MUSTS"

AT MEIJER "WHY PAY MORE" PRICES!

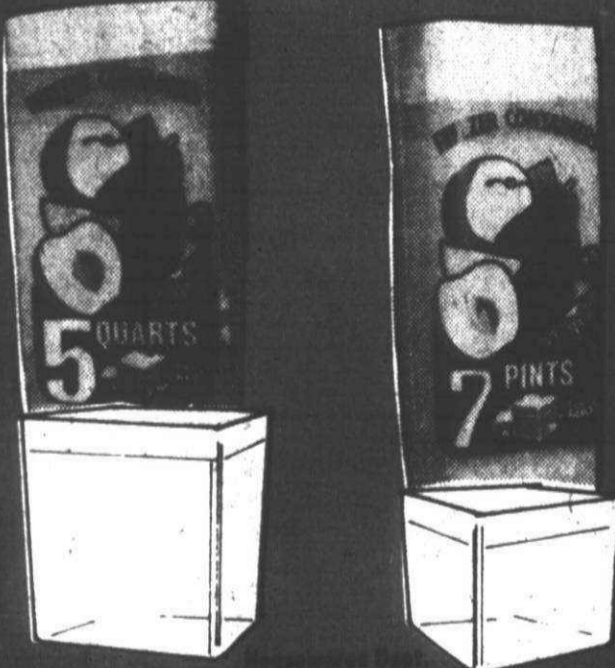

IDEAL FOR STORING FRUIT JARS

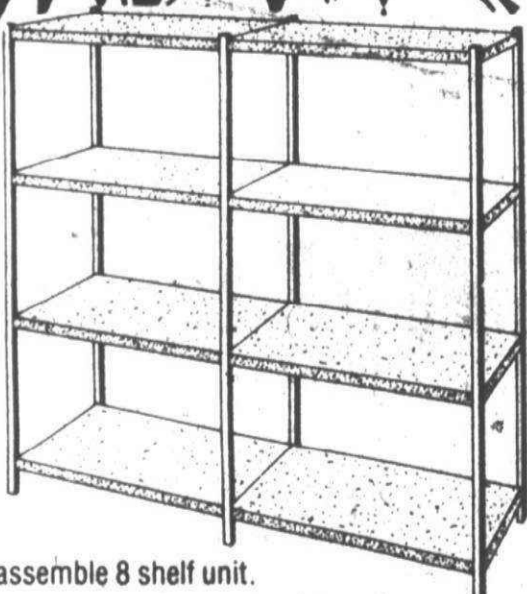

8 Shelves (each 16" x 36")  
72" wide x 60" high x 16" deep  
Model TB862

Alternate ways to assemble 8 shelf unit.

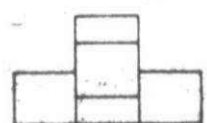

EASY TO ASSEMBLE!

# Spring

## STEEL SHELVING SALE!

ECONOMY STORAGE SHELVING  
This week it cost less to organize your home

Attractive, practical, economical shelving for all your storage needs. All-steel construction for great strength and rigidity. Handsome silver-color shelves have a sparkling pebble-grain finish. Gray posts. Shelves adjustable at 1/4 inch intervals.

Save \$5.00  
OUR REG. \$19.88

**\$14.88** each

YOUR CHOICE!



IDEAL FOR STORING FRUIT JARS

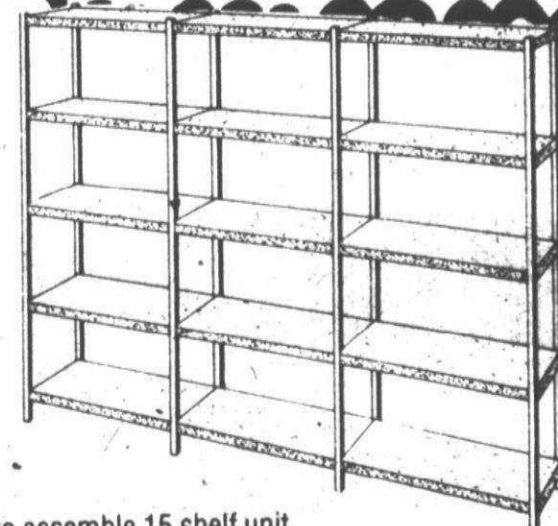

15 Shelves (each 10" x 30")  
90" wide x 60" high x 10" deep  
Model TB150

Alternate ways to assemble 15 shelf unit.



Housewares Dept.



## HIRSH TREND BOOKSHELF/ROOM DIVIDER

The focal point of any room. Walnut woodgrain finish. 16 deep shelves ideal for stereo components. Handsome end bars between shelves keep books upright, provide decorative accent. Just slip them on...no hardware necessary. 16 x 24 x 60". 5 shelves. Model TT344.

OUR REG. \$13.97

**\$10.97** each

# TIME



## 8 QUART MIRROR-MATIC SPEED COOKER CANNER

More flavor, color and vitamins retained. Regulates pressure at 5-10 or 15 lbs. Aluminum alloy, safety fuse, removable pressure control, and self-sealing gasket. Canning capacity: 8 half pints, 7 pints, 4 quarts. Rack and instruction recipe book included.

**\$19<sup>88</sup>**  
AFTER AD \$24.88

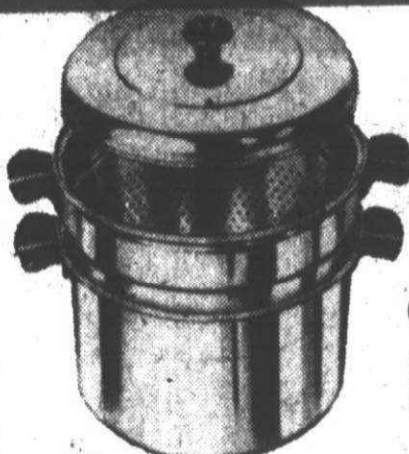

## 6 QUART ALUMINUM BLANCHER

Brilliant polished outside finish. Quick-heat, satin-finish bottom. Heatproof plastic knob and handles.

OUR REG. \$6.47  
**\$5<sup>47</sup>** ea.

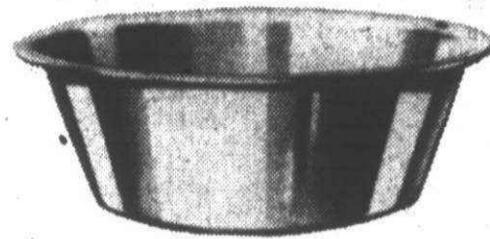

## 14 QUART DISH PAN

Wide rim for easy handling. Has hole for hanging. Use also for washing fruits and vegetables.

OUR REG. \$2.47  
**\$1<sup>97</sup>** ea.

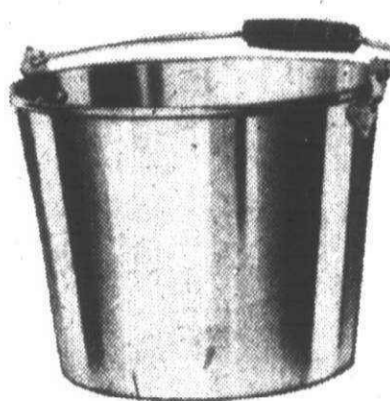

## 10 QUART UTILITY PAIL

Rustproof aluminum, seamless and sanitary...easy-to-clean. Sturdy handle with wood grip. Bright polished outside finish.

OUR REG. \$2.47  
**\$1<sup>97</sup>** ea.

Why Pay More!

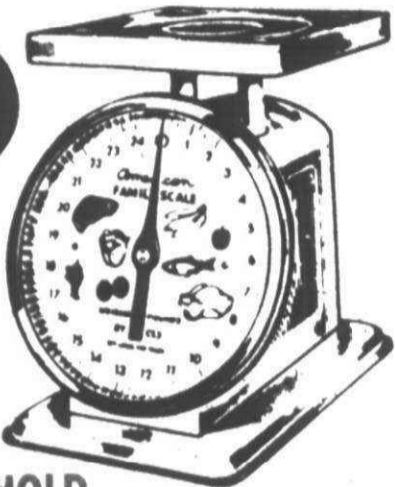

## HOUSEHOLD KITCHEN SCALE

Very handy for home canning. Weighs up to 25 lbs. in ounce increments. Baked enamel finish. Available in white, avocado or gold.

OUR REG. \$4.57  
**\$3<sup>47</sup>** ea.

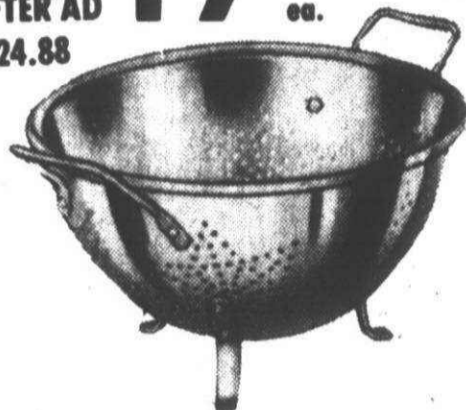

## 3 QUART COLANDER

Ideal for rinsing fruits and vegetables, draining noodles, etc... Extra handy at canning time.

**\$1<sup>37</sup>** ea.

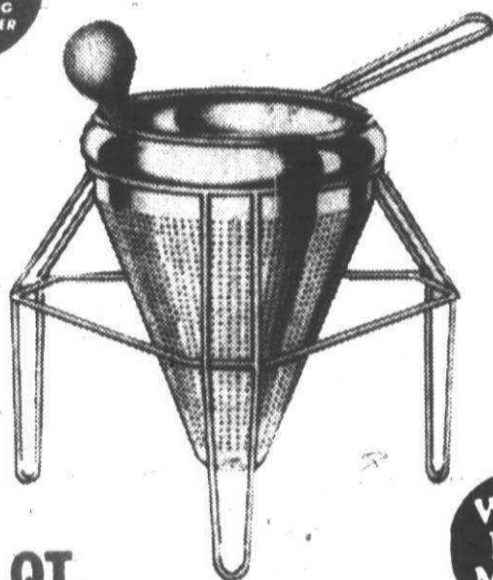

## 2 1/2 QT. ROTARY FOOD PRESS

Kitchen necessity at canning time. Fits over any 4- to 10 qt. pot or kettle for pressing fruits and vegetables. Stain-resisting anodized finish.

OUR REG. \$5.77  
**\$3<sup>97</sup>** ea.

Why Pay More!

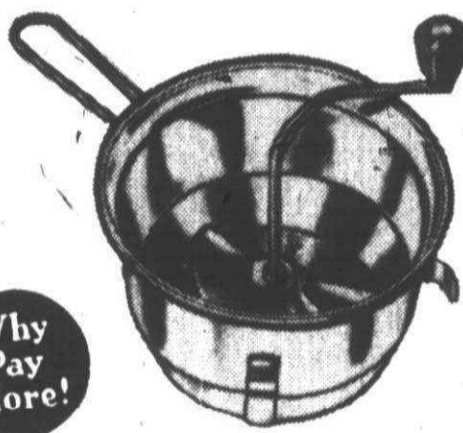

## FOOD MILL

3 1/2 quart capacity mashes, strains, and purees. Ideal for canning, freezing and preserving. Use for sauces, soups, juices. By Foley.

OUR REG. \$6.88  
**\$5<sup>47</sup>** ea.

HAPPINESS IS HELPING YOU

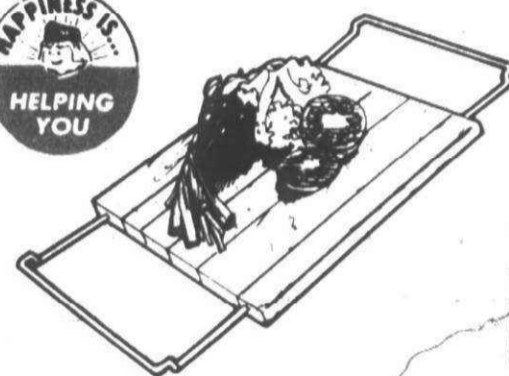

## OVER THE SINK CUTTING BOARD

Vinyl coated steel rails extend to fit sinks up to 20" wide. Gives you additional work surface. Model 121405.

12" x 14"  
**\$3<sup>47</sup>** ea.

Heritage, creativity and personal satisfaction. Equipment to simplify your canning.



CORN CUTTERS



LIKE IT? BUY IT WITH... BANKAMERICARD MASTER CHARGE

HAPPINESS IS SERVING YOU!

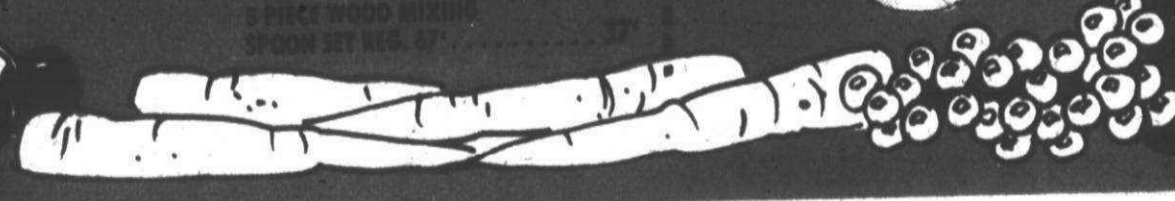

Hirsch

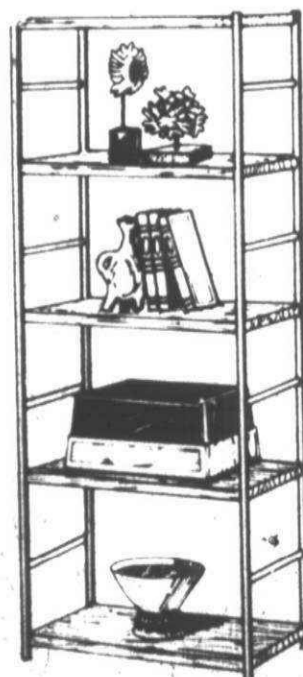

## "The Organizer"

FOR ALL YOUR HOME ENTERTAINMENT COMPONENTS

Choose from "The Organizer" your personal entertainment center, specially designed in walnut finish. 60" x 16" x 32" size. Room enough for TV, stereo, amplifier, stereo speakers, records, pull-out shelf for turntable, tape and cassette storage. Model 960.

## OR STORAGE CHEST BENCH

this versatile storage chest bench with over 3 ft. of poly-foam padded seat. Handsomely finished in walnut print on wood product board with black plastic seat. 18" x 39" x 18 1/2". Model N0840.

SAVE \$10.00

OUR REG. \$36.96

**\$26<sup>96</sup>**

YOUR CHOICE!

Housewares Dept.

Why Pay More!

ITEMS SHOWN ON UNIT ARE FOR ILLUSTRATIVE PURPOSES ONLY.



Model N0840  
versatile STORAGE CHEST BENCH

with over 3 ft. of poly-foam padded seat.

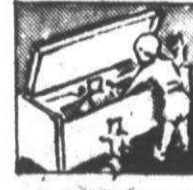

A TOY CHEST



WINDOW SEAT



BLANKET CHEST



FOR TV VIEWING

Handsomely finished in a walnut print on wood product board with black plastic seat. 18x39x18 1/2"

PRICES GOOD MONDAY APRIL 21 THRU SATURDAY APRIL 26, 1975.

MELER RESERVES THE RIGHT TO LIMIT SALES ACCORDING TO SPECIFIED LIMITS.

NO SALES TO DEALERS, INSTITUTIONS OR DISTRIBUTORS.

Page 9

CHARGE ANYTHING IN THE STORE EXCEPT FOOD, LIQUOR AND SUPERMARKET ITEMS



YOU DON'T NEED CASH! USE EITHER OF THESE CONVENIENT CREDIT CARDS!





Housewares

**EKCO. Baker's Secret BAKEWARE**

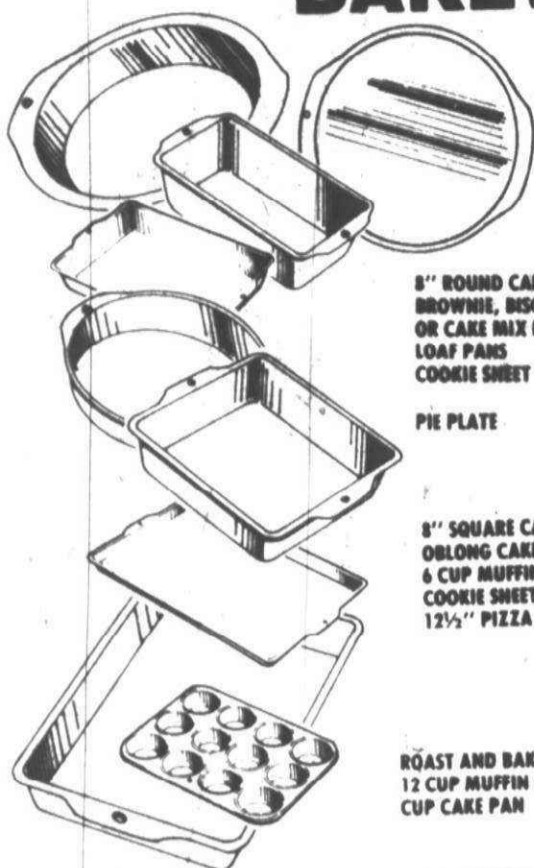

YOUR CHOICE

8" ROUND CAKE PAN  
BROWNIE, BISCUIT  
OR CAKE MIX PAN  
LOAF PANS  
COOKIE SHEET  
**77c**

YOUR CHOICE

8" SQUARE CAKE PAN  
OBLONG CAKE PAN  
6 CUP MUFFIN PAN  
COOKIE SHEETS  
12 1/2" PIZZA PANS  
**97c**

YOUR CHOICE

ROAST AND BAKE PAN  
12 CUP MUFFIN OR  
CUP CAKE PAN  
**\$1.37**



**20 PIECE MELAMINE DINNERWARE SET**

Service for 4. Set consists of 4 each: 10" Dinner Plates, Saucers, Bread and Butter Plates, Cups, Soup/ Cereal Bowls. 4 attractive patterns to choose from.

**\$6.77** set

Housewares Dept.



**MONKEYPOD WOOD CHOPPING BLOCKS**

4 3/4" x 7" x 1 1/2" WITH ROPE HANDLE  
AFTER AD **99c**  
\$1.47

8" x 16" x 1" PADDLE BOARD WITH LEATHER THONG  
AFTER AD **\$1.77**  
\$2.27



IMPORTED FROM THE PHILIPPINES



thrifty acres

**FLAVOR OF THE WEEK**



**CHOCOLATE MARSHMALLOW ICE CREAM**

SINGLE DIP CONE **15c**  
DOUBLE DIP CONE **29c**

Purple Cow at the front of the store

**SPECIAL OF THE WEEK**

**SLIM JIM**

Grilled Ham and melted Cheese on a roll. Topped with an olive sauce.

OUR REG. 69c  
**59c**

**FIRE SHIMP PLATE**

French fried shrimp, French Fries and Cole Slaw.

**\$1.49**

Snack Bar at the front of the store

**DONUT SHOP**

**DILLY BREAD**

OUR REG. 63c

LOAF **57c**

**GLAZED DONUTS**

**6/79c**

Bakery at the front of the Store

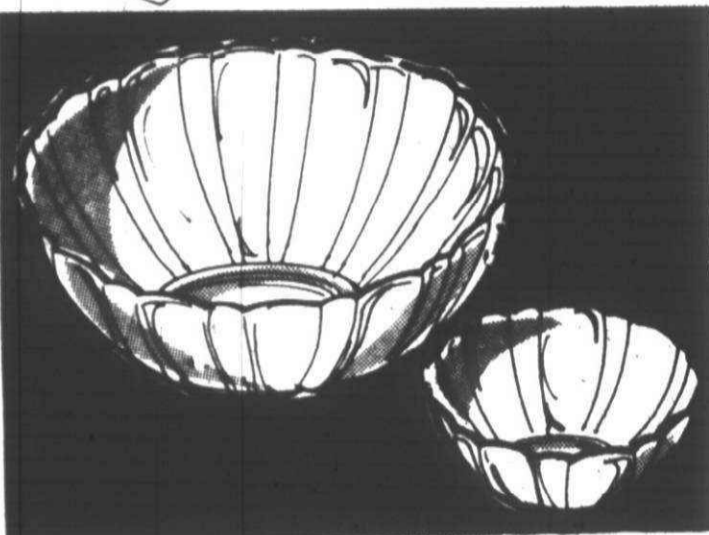

**ARCADE SALAD BOWLS**

By Durand International. Choose from 5" individual salad bowl pkg. of 4 or 9" large salad serving bowl.

**87c** ea.

Housewares Dept.

**CLEARANCE!**

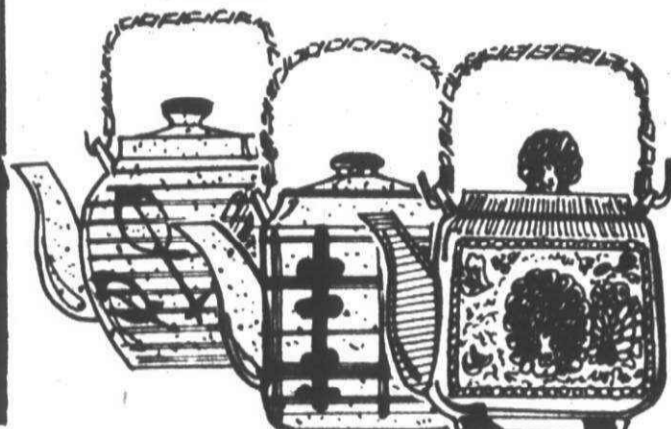

**ORIENTAL TEA POTS**

Durastone Ironstone - keeps tea cold or warm longer. Bamboo like handle. Choose from six decorations.

**\$1.37** ea.

OUR REG. \$2.77

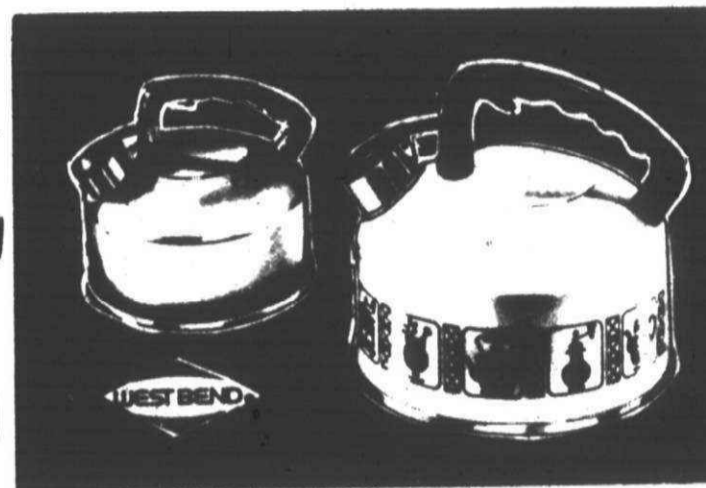

**2 1/2 QT. TEA KETTLE**

Special purchase of slightly irregular. Available in colorful avocado or pantry Art design in gutney brown.

**\$2.47** ea.

Housewares Dept.

*in the Domestic's Dept...*



**POLYESTER KNITS**

Choose from this beautiful assortment just in time for those Summer fashions. Available in solids or fancies. 58 to 60 wide. Machine washable.

**\$1.37** YD.



**ORLON PILLOWS**

A 18" x 24" bed pillow, filled with orlon. Perfect for use in campers or as a lounge pillow.

**\$4.00** PKG. OF 2



**KITCHEN TOWELS**

Terry kitchen towels by J.P. Stevens. Assorted kitchen prints for every decor. Fringed ends.

**69c** ea.

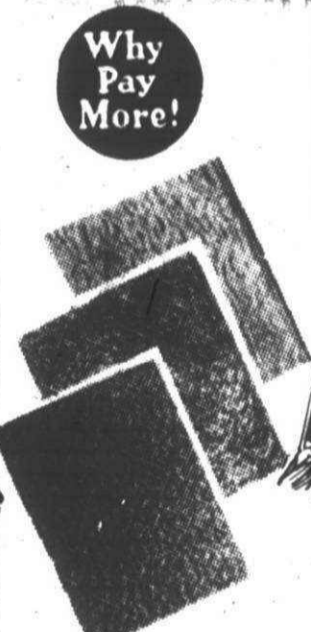

**UTILITY RUGS**

Mill assortment of 18" x 27" carpet pieces. Ideal for use as a car mat or a door mat.

**49c** ea.

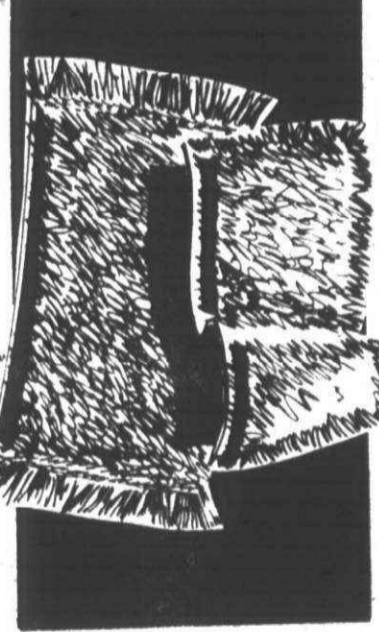

**THROW RUGS**

27" x 45" ceramic style throw rug. Plush nylon blend in a loop cut pile.

**\$3.69** ea.

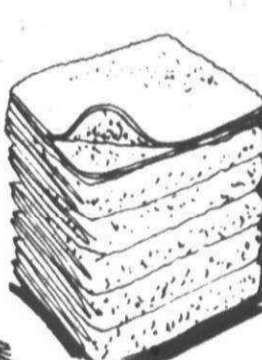

**CANNON WASH CLOTHS**

Special purchase of assorted wash cloths by Cannon. Many colors and types to choose from.

**5\$1** FOR

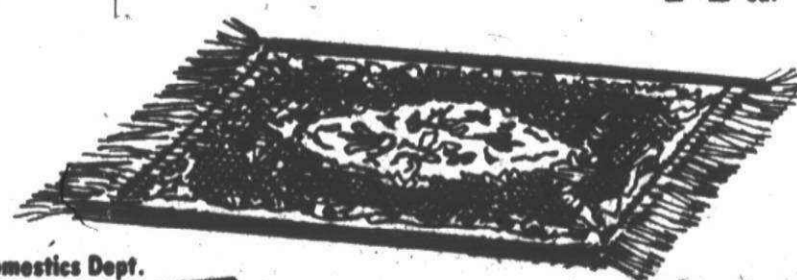

**ORIENTAL DESIGN RUGS**

Oriental design rugs of 100% cotton pile. Belga Royale pattern in sizes 22" x 42" and 30" x 56". Fringed ends.

22" x 42" **\$5.29** ea.

30" x 56" **\$8.97** ea.

Domestics Dept.

*in the Pet's & Crafts Dept....*



**HALF BLACK DELTA TAIL GUPPY**

OUR REG. \$1.08

A beautiful live bearer with wide fan shaped tail (Male).

**\$1.00** ea.

Pet's and Crafts Dept.



**BAG-O-BONES**

OUR REG. \$2.27

Genuine rawhide chew toy. Digestible non-staining. Model 48-407.

**\$1.87** bag

Pet's and Crafts Dept.



**PUP CHIPS**

OUR REG. 98c

Dogs enjoy them. 100% beef hide. Safe, digestible and veterinarian approved. Model 48-105.

**77c** pkg.

Pet Dept.



**GREEN PARAKEETS**

• Undetermined sex  
• Beautiful young birds

**\$4.17** ea.

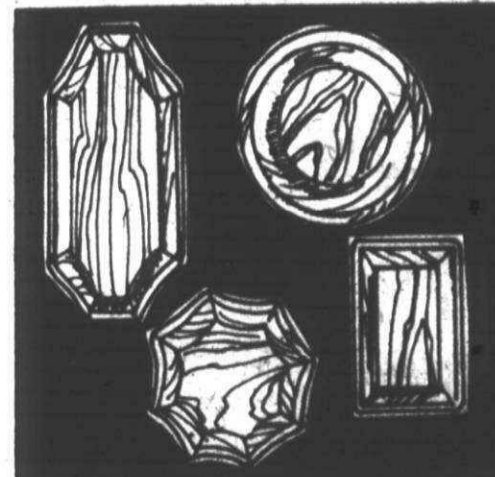

**WOOD PLAQUES**

Choose from 11 different styles. In a basic 3 x 5 size in a thicker 1/2" plaque.

OUR REG. 94c  
**29c** ea.

Page 11

PRICES GOOD MONDAY APRIL 21 THRU SATURDAY APRIL 26, 1975.

MEIJER RESERVES THE RIGHT TO LIMIT SALES ACCORDING TO SPECIFIED LIMITS. NO SALES TO DEALERS, INSTITUTIONS OR DISTRIBUTORS.

CHARGE ANYTHING IN THE STORE EXCEPT FOOD, LIQUOR AND SUPERMARKET ITEMS



**YOU DON'T NEED CASH! USE EITHER OF THESE CONVENIENT CREDIT CARDS!**



Why Pay More! Why Pay More! Why Pay More! Why Pay More! Why Pay More! Why Pay More!

in the Home Improvement Dept... FLOOR COVERING DEPT...

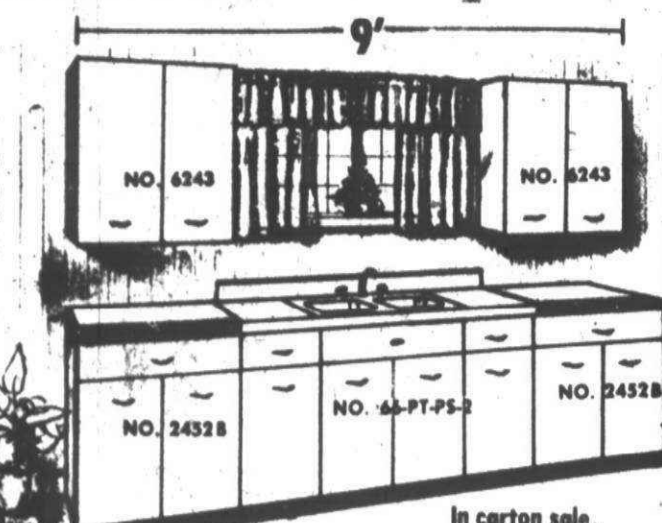

**METAL KITCHEN CABINETS**  
Efficient economical. Assembled with only five cabinets plus sink. Recommended for cottage use.

#6243 LEFT OR RIGHT CABINET  
Special order. Please allow one week for delivery. 24 x 30 x 13 white. **OUR REG. \$31.86 \$27.77** ea.

#2452B LEFT OR RIGHT CABINET  
Special order. Please allow one week for delivery. 24 x 52 white. Colors also available. **OUR REG. \$60.57 \$47.77** ea.

#66PT-PS-2 WHITE CABINET  
Ideal for cabin use. Special order. Please allow one week for delivery. 66" long. White. Colors also available. **OUR REG. \$196.24 \$169.77** ea.

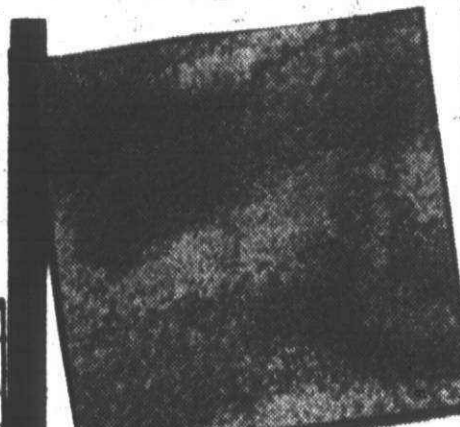

**SCULPTURED SHAG**  
Beautiful high styled carpet made of 100% continuous filament nylon. Long wearing and easy to clean. Attached high density rubberback for do-it-yourself installation. 12' width.

**OUR REG. \$6.99 \$5.99** per sq. yd.



**OUTDOOR CARPET**  
by Armstrong  
Use anywhere outside, patio, sundeck, breezeway, porch or around swimming pool. Lays flat, easy to install. 12' width.

**OUR REG. \$1.89 \$1.69** per sq. yd.



**SUNDIAL NO-WAX FLOOR**  
By Armstrong. Keeps its high gloss without waxing. Sundial cleans like a dream and is cushioned for underfoot comfort. 12' width.

**OUR REG. \$7.95 \$6.58** per sq. yd.

**PAINT DEPT**

**MEIJER BEST PORCH & FLOOR ENAMEL**  
OUR REG. \$7.99 **\$6.59** gal.

**GLIDDEN SPRED SATIN WALL PAINT**  
OUR REG. \$8.79 **\$6.99** gal.

**COLOR TOUCH REDWOOD STAIN**  
Protects and restores redwood beauty. Quick drying and easy clean up.

OUR REG. \$2.49 **\$1.99** gal.

**5 SQ. FT. Z-BRICK**  
Choice of several colors.

ANTIQUE STANDARD RED	SALE \$4.19
ANTIQUE STANDARD OLD CHICAGO	SALE \$4.19
ANTIQUE STANDARD USED	SALE \$4.19
ANTIQUE STANDARD WHITE	SALE \$4.19
COUNTRY RUSTIC RED	SALE \$4.97
COUNTRY RUSTIC SMOKE	SALE \$4.97
COUNTRY RUSTIC BUFF	SALE \$4.97
COUNTRY RUSTIC HARBOR GREY	SALE \$4.97

**Special Buy!**

**ROTARY ON/OFF RANGE DIMMER**  
U.L. listed. 600 watt power. Single pole. Model 110.

OUR REG. \$4.74 **\$1.99**

**#DMP21HK FLOTEC DRILL PUMP**  
Use with any electric drill. Empty clogged sinks, drains, toilets. Changes oil in lawnmowers, etc. Pumps up to 2 1/2 gallon per hour.

OUR REG. \$4.67 **\$3.67** ea.

**FULLER HEAVY DUTY 18" PIPE WRENCH**  
Drop forged alloy steel jaws.

OUR REG. \$6.89 **\$4.88** ea.

**BUILDING SUPPLIES DEPT**

**6'x8' WESTERN CEDAR BASKETWEAVE FENCE**  
Knock down easy to assemble. 4 x 4 x 8' POSTS.

**OUR REG. \$3.99 \$1.588** section.

**INSUL-TILE**  
24" x 48" x 3/4" 24' x 48' eight tiles per package.

OUR REG. \$5.80 **\$3.99**

**CHAIN LINK FENCE FABRIC 50' ROLL**  
Accessories available at Meijer why pay more prices.

OUR REG. \$34.32 **\$28.96**

**DECORATOR PANELS**  
Diamond, glacial, bottle, or starlite.

OUR REG. \$4.97 **\$4.47** ea.

**GALVANIZED EAVESTROUGH**  
Accessories available at low prices.

OUR REG. \$2.19 **\$1.79** ea.

**PICNIC TABLE LUMBER**  
2 x 10 x 6' Reg. \$4.99 **\$3.99** ea.  
2 x 10 x 8' Reg. \$5.49 **\$4.69** ea.

**WAYNE SUMP PUMP #Model SPV-500**  
**\$45.99**

**WAYNE SUBMERSIBLE PUMP #Model SSP-301V.**  
**\$69.77**

**"AMERICAN STANDARD" TOILET SEAT**  
Not all colors available. Fits all regular round toilets. Solid plastic. Model 3.

WHITE QUANTITIES LAST!  
ORIGINALLY \$9.84 **\$5.89** ea.

**HARDWARE DEPT**

**MULTI-POSITION CHAISE LOUNGE**  
Steel frame with vinyl webbing. Use as chair, bed or lounge to relax on. Both ends move up and down in many positions. Choose from avocado/white, brown/yellow or coral/white.

OUR REG. \$10.97 **\$9.97** ea.

**#4105 STRUCTO FOLDING GRILL**  
24 Rustproof chrome plated. 4 height adjustments. Removable tripod legs.

OUR REG. \$9.33 **\$7.88** ea.

**#7413 STRUCTO OPEN WAGON GRILL**  
Sturdy tubular aluminum legs. Heavy duty rustproof chrome plated grid. Easy roll wheels.

OUR REG. \$16.88 **\$13.88** ea.

**FIESTA ROYALE PICNIC TABLE**  
Rigid frame, sturdy construction, antique finish, ornamental scrolls. Folds flat, easy to store. All hardware and instructions included. Save \$5.00.

OUR REG. \$21.88 **\$16.88** ea.

**3 1/2 LB. SINGLE BIT AXE**  
OUR REG. \$10.67 **\$6.66** ea.

**10" CRESCENT ADJUSTABLE WRENCH**  
Chromium plated alloy steel. Model AC110V.

OUR REG. \$6.27 **\$4.66** ea.

**MOTORCYCLE REPAIR MANUALS**

HONDA 50-90cc MANUAL  
HONDA 100-210 cc MANUAL  
HONDA 125-350 cc MANUAL  
HONDA 305 cc MANUAL  
HONDA 350-550 cc MANUAL  
HONDA 750cc MANUAL  
KAWASAKI 90-350 cc MANUAL  
KAWASAKI 250-750 cc MANUAL  
SUZUKI 50-400 cc MANUAL  
SUZUKI 125-500 cc MANUAL  
SUZUKI 300-750 cc MANUAL  
YAMAHA 90-360 cc MANUAL  
YAMAHA 90-350 cc MANUAL

OUR REG. \$5.76 **\$4.46**

**Castrol GTX 4 CYCLE OIL 20W50**  
OUR REG. 88¢ **67¢**

**Castrol Grand Prix 2 CYCLE MOTORCYCLE OIL**  
OUR REG. 75¢ **57¢**

**GUMOUT MOTORCYCLE CHAIN LUBE 15 OZ. CAN #7390**  
OUR REG. \$1.97 **\$1.47**

**GUMOUT MOTORCYCLE CARB CLEANER #7360**  
OUR REG. \$1.33 **\$1.07**

**HONDA OIL FILTER FITS CB350 THRU 750**  
REG. \$1.96 **\$1.27**

**CHAIN BREAKER TOOL**  
REG. \$2.96 **\$1.87**

**HONDA TUNE UP KITS**  
Pre-set points, easy installation.

CB/CL 250/350 REG. \$9.97 **\$8.97**

CB/CL 450 REG. \$9.97 **\$8.97**

CB500 REG. \$9.97 **\$8.97**

CB750 REG. \$9.97 **\$8.97**

**SAVE \$5.00** with this coupon toward the purchase of ANY POLYCARBONATE OR FIBERGLASS SOLID COLORED, METAL FLAKE AND FANCY STYLE MOTORCYCLE HELMET IN STOCK.

Good Mon. Apr. 21 thru Sat. Apr. 26, 1975.

**\$5.00 OFF WITH COUPON**

Meijer THRIFTY ACRES

**TUGSY RIDEM TOY BY EMPIRE**  
Made of tough plastic, bright colored and done in detail. Model 1047.

OUR REG. \$3.96 **\$2.46** ea.

**RADIO FLYER WAGON by Radio Steel**  
Safe-T design handle grip. All nuts and bolts are heavy zinc plated to resist rust. Model 80.

OUR REG. \$6.77 **\$5.97** ea.

**MEIJER THRIFTY ACRES — 45001 FORD RD. AT CANTON CENTER RD.**

SHOP MONDAY THRU SATURDAY 8 A.M. TO 10:30 P.M. — SUNDAY 9 A.M. TO 7 P.M.

Why Pay More! Why Pay More! Why Pay More! Why Pay More! Why Pay More! Why Pay More!

IN THE SPORTING GOODS DEPT.

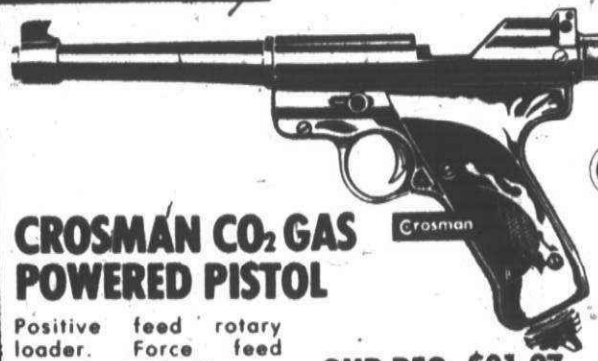

CROSMAN CO2 GAS POWERED PISTOL

Positive feed rotary loader. Force feed magazine holds 16 super B.B.'s. Over 80-shots per CO2 Powerlet. Average muzzle velocity, 350 per sec. Slide action safety and solid steel barrel. Model 454.

OUR REG. \$31.97  
**\$24.97**

Sporting Goods Dept.



Crosman



thrifty acres

100 SHOT BB AIR RIFLE BY MARKSMAN

Positive safety that activates automatically each time it's cocked to prevent accidental firing. Good for sharpening target skills. Model 740.

Why Pay More!

Save \$3.00

OUR REG. \$21.97  
**\$18.97** ea.

Sporting Goods Dept.

TRAVEL BAG

Ladies' 54" vinyl Travel Bag by Laminet. Made of 8 gauge gusseted vinyl.

WHILE QUANTITIES LAST!

OUR REG. \$3.77  
**\$2.97** ea.

Sporting Goods Dept.

TRAVEL BAG

Ladies' 54" nylon Travel Bag by Laminet with a special handle for easy carrying.

WHILE QUANTITIES LAST!

OUR REG. \$6.97  
**\$5.97** ea.

Sporting Goods Dept.

**\$1.00 OFF** COUPON  
SAVE **\$1.00** with this coupon toward the purchase of: **GYM BAG**  
On any bag presently in stock  
GOOD MON. APR. 21 thru Sat. Apr. 26, 1975  
WITH COUPON  
COUPON limited to one per item and per person  
DEPT. 490  
Meijer THRIFTY ACRES

IN THE TOY DEPT...

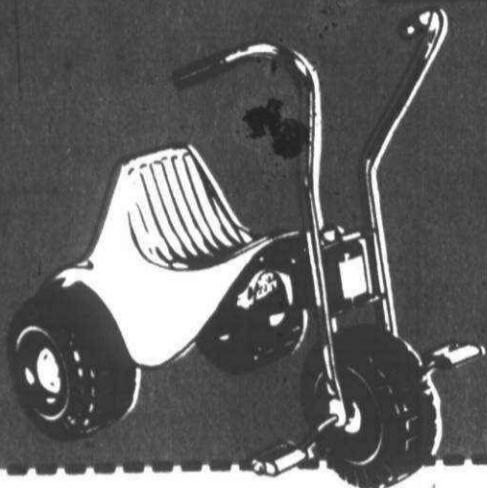

A.M.F. 16" SIDEWALK BIKE

Converts from boys to girls model. Coaster brakes, removable training wheels. Flamboyant goldfish with yellow overtones. Model C98455

OUR REG. \$38.66

**\$29.96** ea.



SOLD IN CARTON

Toy's Dept.

Why Pay More!

FLORAL DEPT...



HANGING PLANTER BASKETS

Choose from Geranium, Boston Fern and three assorted green-foliaged hanging planters. Spring into green!

Why Pay More!

OUR REG. \$4.97

**\$3.97** ea.

Floral Dept.



ARTIFICIAL ROSES

Assortment includes two chairs and two stools. Can be painted or left in natural beauty. Wicker Picnic Basket assortment can be painted or left natural.



WICKERWARE by Watson



W-KC/9 children's furniture. Assortment includes two chairs, and two stools. Can be painted or left in its natural beauty.

AFTER AD \$10.99

**\$7.99** ea.

gift and Floral Dept.



AFTER AD \$15.99

**\$11.99** ea.



#18 RADIO FLYER WAGON

The wagon that generations happily remember. Unsurpassed quality.

Why Pay More!

**\$12.96** ea.

Toy's Dept.

SOLD IN CARTON

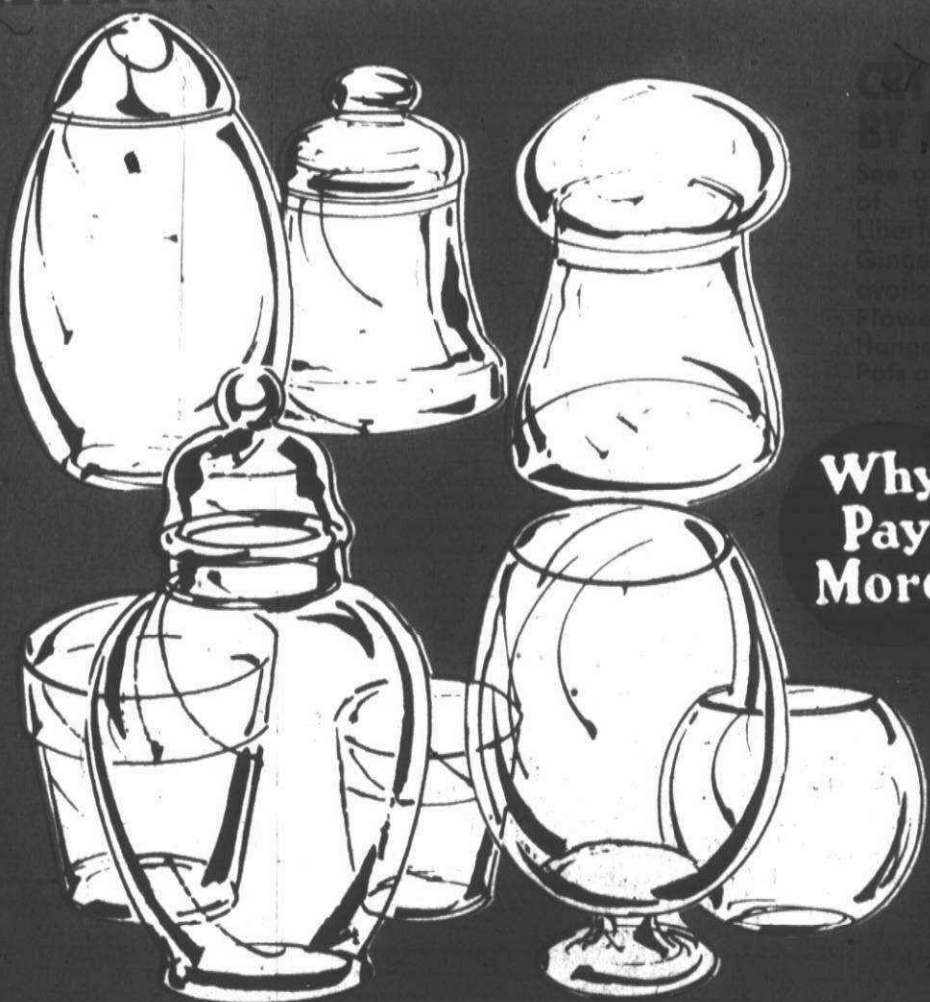

Why Pay More!

PRICES GOOD MONDAY APRIL 21 THRU SATURDAY APRIL 26, 1975.

MEIJER RESERVES THE RIGHT TO LIMIT SALES ACCORDING TO SPECIFIED LIMITS.

NO SALES TO DEALERS, INSTITUTIONS OR DISTRIBUTORS.

Page 13

CHARGE ANYTHING IN THE STORE EXCEPT FOOD, LIQUOR AND SUPERMARKET ITEMS



YOU DON'T NEED CASH! USE EITHER OF THESE CONVENIENT CREDIT CARDS!



Why Pay More! Why Pay More! Why Pay More! Why Pay More! Why Pay More! Why Pay More!

