

Forecast pulls brake on area population boom

By ARLENE FUNKE

Canton officials are not impressed with a prediction that the township's growth will slow to a trickle in the next 10 years.

U.S. Census figures show that Canton's population mushroomed from 11,206 in 1970 to 48,636 in 1980. That caused a strain on services, police and fire protection and gobbled up acreage which previously had been farmland.

But a study released last month by the Southeast Michigan Council of Governments (SEMCOG) projects a growth in Canton population of only 3,000 per-

sons over the next 10 years.

Other areas which will continue to show growth include Plymouth, Northville and Van Buren and Sumpter townships.

Despite the SEMCOG prediction, Supervisor James Poole said he plans to propose an ordinance which would map procedures to control Canton's growth.

"Projections are projections," added Township Clerk John Flodin. "The facts and problems of the day will affect you more than guesses."

SEMCOG is a regional planning agency which covers Wayne, Oakland, Macomb, St. Clair, Livingston, Wash-

tenaw and Monroe counties. Currently, 135 governmental units — including Canton — are members of the agency.

Every 2-3 years, SEMCOG updates its predictions. The information is used for long-range planning in such areas as land use, sewers and roads. In some cases, federal funding for projects is based on participation in a regional plan, explained SEMCOG director Michael Glusac.

"IT'S (the prediction) the best judgment of technical people and local officials — recognizing that nobody has a crystal ball," added Glusac.

"It's a better guide for local officials to make planning," he continued. "It's the only way to bring sense to urban sprawl. In the final analysis, it's the taxpayer who is going to pay for it."

The SEMCOG forecast predicts 1980-90 growth for communities such as Canton, Plymouth Township and Northville. Others may show small population increases, while some decline.

Glusac said the predictions often reflect a shift of population from one community to another within the region.

A sampling of the forecasts shows:

- Canton's projected population for 1990 will be 51,448, compared to 48,360 for 1980.

- Plymouth Township shows an estimated figure of 30,469 for 1990, compared to 23,001 for the earlier period.

- Northville Township is predicted to have a population of 19,658 in 10 years, versus 12,970 for 1980.

- Van Buren Township's projected population for 1990 is 33,829, compared to 18,918 for the previous period.

- Livonia's population is estimated to be 98,611 for 1990, compared to 104,660 in 1980.

Glusac believes most local governmental units tend to be overly optimistic when predicting their own future growth.

"YOU BUILD today for tomorrow's population," said Glusac. "It's then (that) they have to answer the hard question, 'Is it needed — is it justified?'"

"The fact of the matter is, the development of the community can affect another community," added Glusac.

The slowdown in Canton's growth has been developing over the past cou-

(Continued on Page 4A)

Canton Observer

Volume 6 Number 65

Thursday, March 12, 1981

Canton, Michigan

52 Pages

Twenty-Five Cents

1981 Suburban Communication Corporation. All Rights Reserved.

Foster home numbers evoke public outcry

By DARLENE STINSON

One woman fears that a new state law could turn Canton into "a giant mental institution."

A Mayfair man has organized a March 23 meeting at Plymouth Canton High School to increase community awareness of the foster care home issue.

Supervisor James Poole has asked the Michigan Department of Social Services (DSS) to pull together its files and come up with some real answers on the number and types of group homes planned for Canton.

THE CONCERNS are sparked by a 1977 state law which mandates the placement of many mentally retarded and mentally ill citizens in residential neighborhoods.

At present, at least 11 homes for the retarded and the mentally ill are approved or pending in a number of Canton neighborhoods.

Spokespersons for the DSS and other state agencies insist that present institution residents will be transferred to communities across the state in order to meet the mandate of PA 28.

Despite assurances from the DSS, a gnawing concern still plagues many homeowners and officials over the number of group homes which eventually will locate in the township.

At the current time, only one group home application is pending before DSS for both the city of Plymouth and Plymouth Township. At a recent Township Board meeting, state workers estimated that six group homes have been approved for Livonia and one has been approved for Garden City among other communities.

Township officials fear that Canton is receiving more than its fair share of the homes.

Marge Murrell, an adult foster care licensing consultant for DSS, says many communities, such as Romulus, Inkster and Detroit, have a far higher number of group homes than Canton.

But Ms. Murrell and other state workers admit that more group homes are locating in Canton than many western Wayne County communities.

"There are lovely big homes out there that aren't selling," said Judith Shelden, director of community placement for the Northville Regional Psychiatric Hospital. "They're just sitting

there waiting for our investors to pick them off."

Laima Starwas, director of community placement for the Northville Residential Training Center (NRTC), said many home sellers in Canton actually have called her agency with proposals for home sales.

"BECAUSE OF THE public outcry, I

will not open any more homes in Canton," said Ms. Shelden in reference to applications already pending for homes for the mentally ill. "I have no desire to upset a community inordinately."

Her agency — the Northville Regional Psychiatric Hospital — is one of three state institutions which are placing homes in Canton. Spokespersons for the two others — the NRTC and the

Plymouth Center for Human Development — said no additional applications for Canton homes are planned at the current time.

"We're moving in the direction of going to some communities in our service area that don't have as many homes," said Ms. Starwas.

But Canton Supervisor Poole is unwilling to accept their words at face

value. "I feel confident that we're getting more," said Poole. "And that bothers me. What bothers me too is all the rumors and innuendos."

Rumor has it that plans are being formulated to locate at least 30 group homes in Canton.

(Continued on Page 6A)

Man organizes town meeting on foster homes

The president of the Mayfair Homeowners Association has organized a March 23 meeting on the foster care home issue.

"If nothing else, I want as many people as possible to attend," said Paul Black. "I want people to get informed."

The meeting is scheduled to begin at 7 p.m. Monday, March 23, at Plymouth Canton High School.

Black has formally invited homeowner association officials, a number of township officials, State Rep. Tom Brown, D-Westland, and representatives of a number of state agencies which deal with the foster care home issue.

Applications for foster care homes in Black's neighborhood prompted efforts to organize the meeting. One of those applications — for a home at 8503 Manington — was withdrawn this week after a state inspection showed a need for an additional exit, according to Marge Murrell, an adult foster care licensing consultant for the Michigan Department of Social Services. The home would have been used as a foster care facility for mentally ill adults.

Black believes that a number of group home applications for other Canton sites makes the meeting necessary.

CANTON SUPERVISOR James Poole already has promised to attend. He plans to bring along other township staff members, including attorney Jud Hemming.

Poole and other township officials have voiced concern about the number of group homes proposed for Canton. They fear that this community may be getting a higher share of the homes than surrounding areas.

Poole is considering a letter-writing campaign to Canton's state legislators to push for introduction of a bill that would limit the number of group homes that could be placed in any given community.

He called the group home issue "the township's number-one legal priority."

"But I've never committed funds for lawsuits that are lost causes," added Poole, who has talked to a number of attorneys on the group home issue. "They all say that you're wasting your time (to try to stop the homes)."

All the homes proposed or approved for Canton will house the mentally retarded or the mentally ill.

Neighborhood fears concerning both types of homes have surfaced. In recent weeks, however, homeowners have directed many of their concerns toward proposed homes for the mentally ill.

"I HAVE HEARD all the concerns," said Judith Shelden, director of community placement for the Northville Regional Psychiatric Hospital. "But none of these fears are based on fact."

(Continued on Page 6A)



A cure for commuter blues

If you live in Canton but work in downtown Detroit, the long and costly drive on traffic-congested freeways may be getting on your

nerves. An increasing number of residents are opting for a less hassled way to and from work. For the story, turn to Page 3A.

(Staff photo by Gary Caskey.)

'A monkey-napping'

Pet shop owner offers reward to get Bobo back

By ARLENE FUNKE

The thief who broke into Pets "R" Us on Ford Road early this week may be feeling like a monkey's uncle.

Canton police investigating the break-in at the store about 3:37 a.m. Sunday reported the only thing taken was owner Dan Daniels' pet squirrel monkey, Bobo.

Daniels said the monkey — imported from South America — might die if it doesn't receive proper care and food. "If they don't take care of him

(Bobo), he won't make it," said Daniels. "You have to know something about the monkey. Table scraps would kill the monkey. Chips or salty food (would be bad)."

Daniels has offered a \$100 reward for information leading to the return of Bobo.

"Whoever did it didn't want anything else," said Daniels on Tuesday. "People keep coming in and asking, 'Where is your monkey?'"

"It was more or less a drawing card," added Daniels. "He'd jump

around teasing the (other) animals."

POLICE Lt. Larry Stewart said police went to the store early Sunday morning, moments after a citizen phoned to report the sound of breaking glass nearby. The shop is in the New Towne Plaza shopping center, near Ford and Sheldon.

Investigation showed the burglar had used a chunk of rock to break a hole in the glass door.

The monkey's food and water dish were found outside the doorway, according to the police report. The cage

— also found outdoors — was at the rear of the store.

Bobo is valued at about \$500. Damage to the door is estimated at \$300.

According to Daniels, the squirrel monkey is about 1 foot long and weighs about three pounds.

Daniels usually fed Bobo small insects — such as crickets and meal worms — bananas, apples, nuts and seeds.

Anyone who has information about the monkey should call Daniels at 455-7480.

what's inside

- Amusements 8-10B
- Brevities 11-12A
- Canton Chatter 2B
- Church 6-7B
- Clubs in Action 4-5?D
- Obituaries 2A
- Opinion 14A
- Readers Write 12-13A, 16A
- Sports 1-4C
- Suburban Life 1-5B
- The View 1-5B
- Travel 5C
- Classified Sec. C-D

Ready for a Change?

If you're thinking you need a change around the house, you can bet others are thinking the same. Judy Popransky was ready to part with her waterbed, but knew it was still a good value. One ad in her hometown O&E classifieds brought her 67 calls on the first day and a sale.

There's a good chance that what you're looking to sell, others are looking to buy.

Remember, one call does it all...

591-0900

Schools hold last boundary hearing

The modified Plan III likely will be changed a bit more before Plymouth-Canton Community Schools comes up with a final boundary, calendar and grade alignment plan for the coming school year.

Monday night, school board members indicated they would seriously consider at least two, and possibly three, changes in boundaries involving elementary and middle school attendance areas.

The school board is holding its final public hearing tonight on modified Plan III beginning at 7:30 p.m. in the gym of the athletic and music facility

(Canton Phase III) which is located between Plymouth Salem and Plymouth Canton high schools at Joy and Canton Center roads.

The fifth and final public hearing on redistricting will be broadcast live by WSDP-FM (88.1), the student-operated radio station at the Plymouth Centennial Educational Park (CEP).

The board is expected to make a final decision on the redistricting plan at a special meeting for Monday, March 16, in the board of education building in Plymouth.

Board President Carol Davis says a decision

must be made soon on redistricting so the administration and board can make decisions on hiring staff, bus routes, class schedules and curriculum.

Residents wanting to know about the changes being considered from the modified Plan III, or about the changes made from the original Plan III, may call the community relations office of the school district at 453-0200.

Among the staffing decisions to be made yet is the hiring of a new principal at Lowell Middle School, which is expected to be made in two or three weeks.

District eyes bus options

The modified Plan II likely will be changed a bit more before Plymouth-Canton Community Schools comes up with a final boundary, calendar and grade alignment plan for the coming school year.

Monday night, school board members indicated they would seriously consider at least two, and possibly three, changes in boundaries involving elementary and middle school attendance areas.

Board filing deadline approaches

A decision was made Monday night by the Plymouth-Canton Board of Education to approve a contract costing about \$44,000 for a computer service firm to handle the bus routes for the coming school year.

The contract was approved with Ecosystems Inc. of Cleveland, which has been doing the bus routes for the school district since 1977.

The firm also is being used currently for introducing computer simulation plans for redistricting options for the coming school year.

Ray Hoedel, assistant superintendent for business, says Ecosystems' services are very much needed this year because of the many changes in school attendance boundaries, the addition of a fifth middle school in Lowell, partial grade realignment, and expansion of Extended School Year (ESY).

The information obtained from Ecosystems will

be stored into the computer operated by the Wayne County Intermediate School District, Hoedel added.

If there are fewer changes next year, he said, then the district might be able to take the information stored in the intermediate district's computers and devise a bus routing plan in-house without having to rely on Ecosystems.

Hoedel also suggested the administration might try a bus routing pilot program in '81-82 using the intermediate computers with the idea of doing the work in-house for school year '82-83.

Right now, said Hoedel, the county computers are unable to handle bus routing, but they do have the storage capacity to retain the bus routing program developed by Ecosystems.

In other action, the school board also approved a contract with Westinghouse to produce class schedules next year at the Centennial Educational Park (CEP).

obituaries

WILLIAM WARREN HEYMES

Services for Heymes, 55, of Canton were held recently at the Harris Funeral Home with Rev. Raymond Babb officiating. Burial was at Parkview Cemetery.

Heymes, who worked as a restaurant employee, died Feb. 28. Survivors include his brother, Neal; and sisters, Margaret Pasehal, Dorothy Jones, Edna May Roberts and Barbara Poitevint.

REBECCA JOSEPH

Services for Mrs. Joseph, 86, formerly of Plymouth, will be held Friday at Paulin Funeral Home, Mancelona, beginning 1 p.m. with Rev. Marvin Iseminger officiating. Burial will be at Curtiss Cemetery in Petoskey.

Mrs. Joseph, who died March 9, was a member of the Central Christian Church. She resided in Plym-

outh until last November. Survivors include her son, Virgil of Bull Shoals, Ark.; daughters Lucille Adams of Mancelona and Eleanor Graham of Petoskey; eight grandchildren; 28 great-grandchildren; and five great-great-grandchildren.

ROBERT E. LEE

Services for Lee, 56, of Plymouth, were held recently at Schrader Funeral Home with Rev. Kenneth Zielke of the Lutheran Church of the Risen Christ officiating. Burial was at United Memorial Gardens.

Lee, who died March 1, was a veteran of World War II. Survivors include a son, Robert Jr. of Chicago; a daughter, Mary Catherine of Ithaca; brothers Clarence and Earl; sisters Margaret Caveyou, Beatrice Rose, Charlotte Mason, Shirley Gazdog, Dorothy Bingham, Roseann Mullee and Lorretta Lange; and a grandson, Rickie of Ithaca.

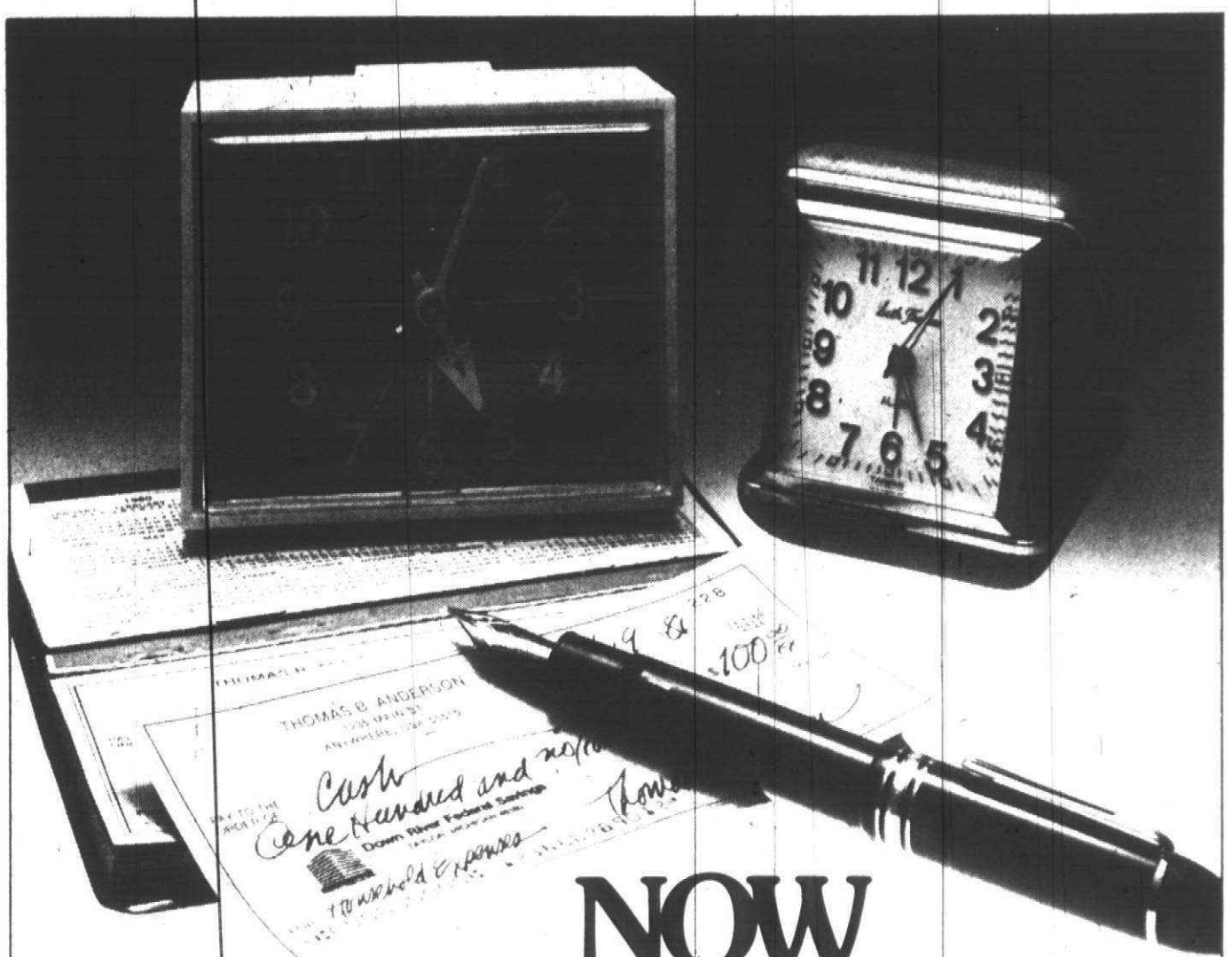

NOW is the right time to "CHECK n' save"

Now a \$100 opening balance in your "Check n' Save" interest bearing checking account earns 5 1/4% daily interest. You can now open a "Check n' Save" checking account for only \$100. Maintain a \$500 minimum balance and there's no service charge. AND you earn 5 1/4% daily interest. You'll use the account just like you would any checking account, and it will earn you daily interest just like your savings account, including interest on funds for which you've written checks until those checks have cleared. And we'll provide you with up to 3 check copies per month FREE, or all copies required for an IRS audit at no charge. Service charges will be waived for the following automatic deposits: payroll deductions, trust payments, retirement checks, direct deposit of Social Security or any other recurring payments. Open your "Check n' Save" checking account today with \$500 or more, and receive a timely gift from us through March 31, 1981.

A timely gift to you from us. Open a new "Check n' Save" interest bearing checking account and receive a gift from us FREE, for a deposit of \$500 or more.

YOUR GIFT	DEPOSIT \$500 or more and choose one item
150 Duplicate checks	ANY ONE FREE
Westclox Electric Alarm Clock with drawser interlude	
Seth Thomas travatour travel Alarm Clock	

Win a 23-inch Zenith console color television! We'll give you \$2 for each remaining check from your present checking account that you have at another financial institution. Plus, one of your checks will be entered in a special drawing for the 23-inch Zenith console color television.

Regulations restrict the number of gifts to one per person and require customer. See also all-ways for funds restrictions on the 23-inch Zenith console color television, and another time with us. March 12, 1981.



Big. But downright neighborly.

Down River Federal Savings

- 24 NEIGHBORLY OFFICES TO SERVE YOU
- HOME OFFICE: TAYLOR, 28699 Eureka Rd., 295-3000
 - ALLEN PARK: 8634 Allen Rd., 381-2500
 - 6770 Allen Rd., Dearborn
 - CANTON TOWNSHIP: 42448 Cherry Hill, 981-2608
 - 41575 Van Rd., 454-1410
 - CARLETON: 8550 Monroe St., 241-6600
 - DETROIT REDFORD: 24550 W. Nichols, 471-4700
 - FLAT ROCK: 27601 Telegraph, 782-1411
 - GROSSE ILE: 8005 Mackcenter, 625-8000
 - INKSTER CHERRY HILL: 29700 Cherry Hill, 278-1000
 - LIVONIA: 45111 N. Main, 271-1400
 - MELVINDALE: 8615 Oakwood Blvd., 862-2600
 - MONROE: 306 N. Main, 243-0000
 - NORTHVILLE: 21100 Northville Rd., 248-8000
 - RIVER ROUGE: 2011 Dixie, 241-1000
 - RIVERVIEW: 6711 E. River, 282-3000
 - SOUTHGATE: 17625 E. River, 282-3000
 - TAYLOR: 22101 E. River, 282-3000
 - TRENTON: WOODHAVEN, 282-3000
 - WYANDOTT: 282-3000

Member Federal Savings and Loan Insurance Corporation. Your Savings Insured to \$100,000.

SILK FLOWERS
50% Off
by
J.P. Designs
Call 459-8067

THE STIHL 028WB.
THE PROFESSIONAL SAW FOR HOMEOWNERS.

BUY NOW and get the Stihl strong case, file handle, 5 1/2" wedge, 8 oz. Stihl oil and Stihl firewood booklet FREE with 16" Bar & Chain \$328.63

STIHL
The World's Largest Selling Chain Saw

SAXTONS GARDEN center inc.
587 W. ANN ARBOR TRAIL
PLYMOUTH • 453-6250
MON. THRU THURS. 9-6
SAT. 9-5

Gary B. McCombs, P.C.
Certified Public Accountant

Business and Personal
Taxes and Accounting

Evening and Weekend
Appointments Available

7340 Burgundy Dr.
Canton, MI 48187 **455-8208**

SLEEP ON YOUR CHOICE FROM ONLY... \$69 Twin ea. pc.

SERTA SALE THIS WEEK ONLY!

The Towne and Country treatment means you'll find no salespeople at Towne and Country Interiors — only IDS and ASID interior designers to help you. And that goes whether you're looking at a sofa, a whole room or this bedding. Plus, our pay-no-more policy and 3 year Construction Warranty ensure your satisfaction.

Specially tempered inner coils, layers of foam and puffy cushioning. Steel grid-top foundation, non-sag edging and Serta built-in comfort make these all an unbeatable value!

All Posture sizes on sale!

Size	Firm Postureguard	Extra Firm Postureguard Deluxe
Twin	\$69. ea. pc. Reg. \$99.95	\$89. ea. pc. Reg. \$119.95
Full	\$109. ea. pc. Reg. \$139.95	\$129. ea. pc. Reg. \$159.95
Queen (sold in sets)	\$109. ea. pc. Reg. \$177.50	\$129. ea. pc. Reg. \$197.50
King 3pc. set (sold in sets)	\$109. ea. pc. Reg. \$165.00	\$129. ea. pc. Reg. \$183.33

FREE FREE FREE

11 DANGER SIGNALS

FREE • CONSULTATION
FREE • EXAMINATION
FREE • X-RAY EVALUATION
FREE • 1ST SPINAL ADJUSTMENTS
FREE • NUTRITIONAL CONSULTATION

DID YOU WONDER IF YOUR HEALTH PROBLEM WAS DUE TO PINCHED NERVES

IT WILL COST YOU NOTHING TO FIND OUT IF WE CAN HELP YOU

FAMILY HEALTH CARE PLAN: BASIC OFFICE CALL \$12.00 NO CHARGE FOR ADDITIONAL FAMILY MEMBER

ADAMECZYK Chiropractic Health Clinic

9325 HAGGERTY (ACROSS FROM K-MART) PLYMOUTH M,W,F 9-7 Sun. 11-5 **455-7560**

Towne and Country Interiors

Dearborn 565-3400
23600 Michigan Ave. east of Telegraph

Bloomfield Hills 642-8822
4107 Telegraph at Long Lake Rd.

Rochester 652-3500
1110 S. Rochester Rd. in Winchester Mall

Open daily 10-9 Wed. & Sat. 10-6 Use our convenient charge, Visa or Master Card

'Park it here and leave the driving to us'

In early morning hours, and then later in the day, commuters heading to downtown Detroit offices are found congregating in shopping centers, places of industry and even church parking lots.

There they wait, with coffee cups in hand, and sleep in their eyes, for the near one-hour bus ride to the city.

Not since the days of train travel have suburban commuters seen such hassle-free traveling.

The trains heading into and from the Plymouth-Canton community are gone now and have been replaced by the silver bus fleet of the Southeastern Michigan Transportation Authority (SEM-TA).

A survey of park & ride lots in the area found most commuters using the SEMTA system are satisfied with it as an economical means of getting around. Some, reminiscent of commuter trains, relish the comforts of "leaving the driving" to someone else.

In the Plymouth-Canton community, there are three park & ride lots where residents can leave their cars until their return at the end of the day.

Some 30 miles from Detroit, this is SEMTA's furthest western point.

According to SEMTA figures, park & ride lots, which have been used for four years, last year had a 70 percent increase in users.

ONE PLYMOUTH commuter who has been taking the SEMTA bus downtown from the Sheldon Road Ford Plant is Paul Toth, a federal government employee.

Toth, a former train traveler, esti-

mates a yearly cost savings of \$10,000 in taking a bus instead of his personal car. The 50-minute trip from that site to downtown Detroit is 60 miles round-trip.

"When I first started taking the bus three years ago they had three buses leaving this site — now it's up to 11," he said.

Aside from the gasoline savings, Toth notes a "break" on his car insurance as well as his policy now lists his car for "pleasure" use alone.

One of the benefits of commuting by bus, he says, is "you don't have to be concerned about road conditions. You just read a little, snooze and relax."

One of the most heavily used lots, averaging some 500 morning travelers, is in the Ford-Sheldon Road parking lot. It's in the center's southeast corner and is designated by a red and white SEM-TA sign.

The only other park & ride lot in Plymouth Township is found in the Church of Christ parking lot on Sheldon Road, a few blocks south of Ann Arbor Road. This lot is not readily visible as it's directly behind the church building on Sheldon. The newest lot opened by SEMTA in this area, it averages some 150 morning travelers.

IN CANTON TOWNSHIP, commuters heading east can pick up any of several buses in the parking lot of the Meijer's Thrifty Acres site on Ford Road near Canton Center Road.

For \$48 a month, one can purchase a SEMTA pass which allows use of any bus in the system, said SEMTA spokesperson Gerald Zahler. A one-way

fare from most locations in this area is \$1.60.

"It's like a steal, it's so cheap," added another SEMTA bus user, Andrew Telek, an assistant Wayne County prosecutor.

"I can now keep this another couple of years now," he adds pointing to a rusted-out older model car.

Taking a bus as opposed to using one's personal car also requires some planning in studying bus schedules and departure times.

But even this extra-planning does not turn some commuters off.

"It's no problem at all," said commuter Ed Schneider of Plymouth Township, a Blue Cross-Blue Shield employee. "I just work my schedule around the time the bus leaves."

As an added bonus for Canton residents, SEMTA cards also are honored by the Nankin Transit Commission, a small bus service operating in Canton, Westland, Wayne, Garden City and Inkster.

SEM-TA cardholders are eligible for daily dial-a-ride pick-up from their doorsteps by Nankin buses to park & ride lots operated by SEMTA. In Canton Township, this service is not heavily used, averaging some nine residents daily.

HERE'S A rundown of the number of stops made at each park & ride lot in the Plymouth-Canton community. More scheduling information is available by calling SEMTA at its suburban number, 1-800-462-5161.

• Ford-Sheldon: Eleven buses leave between 5:50 and 8:10 a.m. In the even-

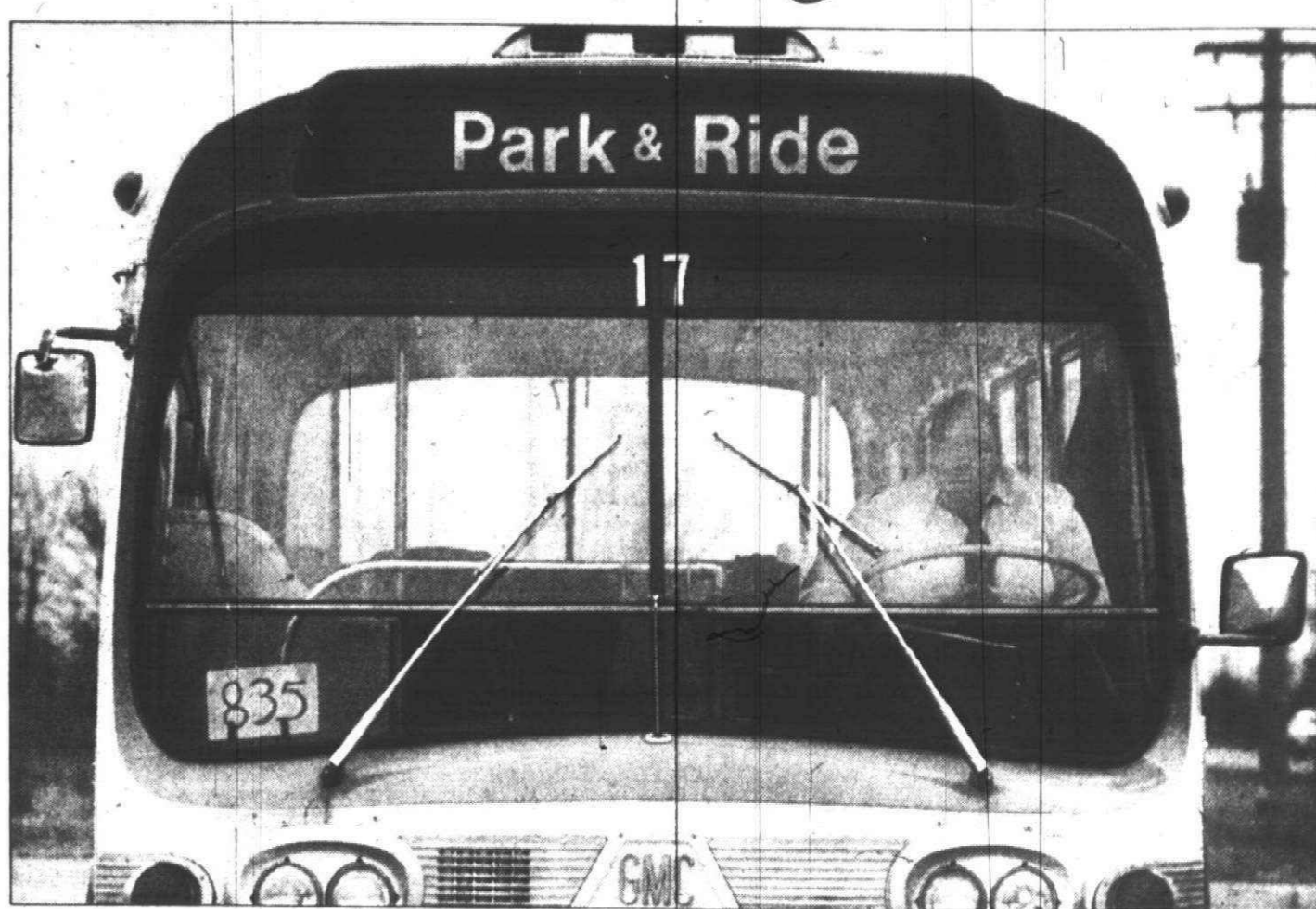

This driver drops off his last home-bound passengers at a SEMTA park and ride lot near Meijer Thrifty Acres. (Staff photo by Gary Caskey.)

ings, buses return from downtown Detroit between 5:10 and 6:54 p.m. The ride from the lot takes about 50 minutes and entails three stops before arriving in Detroit.

Church of Christ: Three buses leave every 25 minutes at 6:24, 6:51 and 7:19

a.m. Buses return between 5:42 and 6:50 p.m. The ride lasts about 55 minutes before reaching several stops in downtown Detroit. The buses from this lot make three stops along Plymouth Road and Telegraph before taking I-96 east.

• Meijer's: Six buses leave between 5:55 and 7:20 a.m. Seven buses return between 5:25 and 6:45 p.m. The trip to Detroit is estimated at 55 minutes long and involves three stops along Ford Road before picking up I-94 at the Wyoming Street exit.



Rehearsals are serious for the Dittilies. Kim Stewart (left) goes over a number with Dave Danielle, Steve King and stage manager Jim Price. In the back are Bob Garcia and Kyle Olson. (Staff photo by Art Emanuele.)

Dittiliemania

Rock group tunes in to nostalgia

By MARIE MCGEE

Nonsense and nostalgia rock to the solid beat of the '60s wherever the Dittilies go.

Right now, they're a going thing at Center Stage in Canton Township, where they've set a couple of attendance records since becoming the official house band for the arena-like music hall a year ago.

That setting is a far cry from the Livonia Bentley High School auditorium where it all began nine years ago. They were called the "Bo Diddlys" then — five seniors who did a mimicry of the Presley era as part of the school's concert choir's annual variety show.

They stole the show then, and they're still doing it — only now it's a full-time business with all the ups and downs that are part of the glitzy world of show business.

Only two of the original members of the group have hung in there — Steve "Buddy Love" King and Kim "Moon" Stewart. But while the other three bowed out right after high school, the present six-man group still has five Bentley graduates wailing away, with the sixth man — Dave "Doctor Z" Danielle a native of New Jersey.

CURRENTLY MIXING it up on drums is Bob "Bongo Bob" Cicotte, Jim "Captain J.J." Jones, guitar, and Kyle "Kool Kat" Olson, bass. Even the sound man, Bob Garcia, is a Bentley graduate. King and Stewart do the vocals.

All of them go back to "High School" just about once every weekend with their rendition of the stock favorite by the MC-5. Part of the fun is donning green-and-white tasseled mortarboards and the humorous references to former principal Al Zack, who was principal at Bentley at the time the group formed, but who is now at Franklin High School.

Along the way, the group dropped "Bo" and changed the d's to t's from their name when they found that occasionally people were mistaking them for the legendary black rhythm and blues singer.

Turning pro actually didn't happen until all five of the original group had graduated in 1972.

"IT WAS REALLY flukey," recalls King, who acts as the group's manager. "We had started to go our separate ways and we'd run into old classmates who never seemed to forget what we had done in that show, and they'd say, 'Hey, why don't you do it professionally?' After a year of working and fooling around, we were bored and thought we'd give it a whirl."

The '50s fad was big then, King said. They put together an act and began playing at junior and senior high school dances. Then it was clubs and lounges — including a long run during the Driftwood Lounge's raucous heyday as a rock and roll circus — before the Center Stage gig. They also make frequent appearances at the Second Chance in Ann Arbor.

They're also the only live band to play Oscar's, a Southfield discotheque.

THE GROUP likes the vastness of Center Stage, because it's a "concert situation," even though it's basically a bar. It fits the Dittilies' needs for space "to really wail and jump around in," and at the same time has helped Center Stage management keep going in a highly competitive field.

Center Stage was in a tight money bind until a new manager was named last June and he brought in the Dittilies. Now, the management is doing better financially with a mix of area talent and some name stars.

"The Center Stage operation is too small to pay for the really big stars like the ones that come to Pine Knob, but it's too big for most local bands. We fill the gap," King said.

Filling the gap means drawing upwards of 1,000 rock and roll fans every Thursday, Friday and Saturday to the cavernous Ford Road music hall that has a 1,400 capacity. Last November, the group set an all-time attendance record of 1,472. That was better than any big name act that CS management has booked in its two years of operation.

THEY ALMOST did again several weeks ago, when WJBK-TV's "PM Magazine" filmed the Dittilies in action during a Thursday Ladies Night show. A thousand screaming females set the tone for the Dittilies' zany antics that included making their stage entrance in the miniest of the minis — King's restored 1972 four-door Honda auto.

The TV cameras ground away as the group went through its routine of comedy skits and prop changes.

That show and an interview with King will be aired on TV-2 on March 29.

The group shifted from the '50s to the '60s music because, King said, "no was doing it, and I happen to think that was the era the greatest songs were written."

Consequently, the Dittilies do a lot of songs by the Beatles, Beach Boys, Ted Nugent, Bob Seger, The Who and the Rolling Stones. They change the material frequently and work hard on the comedy sketches.

"WE DO SOME blue — or slightly objectionable — material, but we never try to offend anyone," said King, who was extremely active in drama during his high school days.

"Music is a business, and you have to treat it as such," he said. King is the group's business agent and sees to it that the bills are paid. That includes paying off \$40,000 they have invested in sound equipment.

He admits he's "big on gimmicks" like T-shirts and buttons, and even passes out ballpoint pens with a Dittilie message on it. Fans are kept apprised of the latest Dittilies shenanigans by a special hotline that King updates every week.

Cable advisory group looks for program ideas

Canton's cable TV advisory committee is looking for some good ideas from civic groups.

Charles Miller, committee chairman, said four slots from the civic groups category must be filled.

The purpose of the group is to promote and coordinate programming on local access channels for a cable TV system which is being installed in Canton. The system is supposed to broadcast government news, public affairs programs, sports and others.

Prospective members may apply by attending the next regular meeting of the committee, at 7:30 p.m. March 17, in the library meeting room in Township Hall.

"OUR COMMITTEE is advisory," explained Miller. "Participation is strictly voluntary."

"I would expect some interest might be cyclical," he added. "They (may) want to be on the committee at a certain part of the year."

According to the committee bylaws, the 17-member advisory group is to be composed of nine residents (called community representatives) and one member each from eight civic groups.

All the community representatives' positions have been filled, said Miller. Some of the groups already represented are Schoolcraft College, League of Women Voters, Canton Library Board, Plymouth-Canton Schools and Chamber of Commerce.

Members who miss three consecutive regular monthly meetings will be dropped from the committee, according to the bylaws.

Miller said the advisory committee is interested in helping groups promote special events and activities.

"THAT'S WHAT we would just love to help them

out with," said Miller. "We want to be a common voice of the community — to provide a sounding board."

"We don't want people to think we're trying to control them," he added.

Another important function of the committee is to be a liaison between the groups and the cable TV company for scheduling on the local access channel. And a special committee will make sure that groups and individuals are trained on how to use the equipment.

Holding the franchise rights for Canton's cable TV system is Omnicom of Plymouth.

Peter Newell, president of Omnicom, said the advisory committee concept is fairly common in the cable TV industry.

"(These people) work and live in the community," explained Newell. "They understand what its needs and problems are."

"We aren't trying to compete against Channel 4 and Channel 7," added Newell. "But we can do things in this area that nobody has been able to see on TV before."

ACCORDING TO Newell, only about 12 homes in Canton already have been wired for the cable TV system.

Construction of underground wiring in the township — halted by winter weather — is expected to resume after the spring thaw, said Newell.

As the wiring moves forward, more homes will be added. Completion is targeted for the end of this year.

Canton awarded the franchise bid to Omnicom in December 1979.

Board members felt Omnicom could offer better services to the entire Plymouth-Canton area.



OASIS GOLF CENTER

DRIVING RANGE AND MINIATURE GOLF

OPEN March 14 - Nov. 1

Hours: 11 A.M. - 7:30 P.M. DAILY

Heated Tees - Newly Installed

Save Money Ask about our new VIP Card

Golf Ball Sale

New PGA 15 BALL DOZEN

\$14.50

Golf Gloves

Leather \$4.99

Wilson All Weather \$4.75

Golf Shoe Sale

DEXTER "Waterproof" Sale \$28.95

DEXTER "Soft Leather" Sale \$43.95

ETONIC "Leather Waterproof" Sale \$53.95

PRO SHU Limited Sizes Sale \$27.95

Browning "Nylon" Carry Bag \$23.95

Monogram Shop Sharp Monograms \$5.00

Your Merchandise or Ours

Pro Shop Hours 10 a.m. - 6 p.m.

Levin tackles voters' concerns

By SUSAN ROSIEK

Hundreds of people packed the Livonia City Hall auditorium last Saturday to vent their frustrations and question U.S. Sen. Carl Levin about a host of issues ranging from rising taxes and energy costs to federal budget cuts and state unemployment.

Residents, local and state officials from throughout western Wayne County, and representatives of several special interest groups and organizations were on hand for the 90-minute question-and-answer session hosted by the Michigan Democrat. Among those represented were We The People Act, an organization which believes the federal tax on wages is unconstitutional; Equal Rights for Fathers; Conservative Caucus; American Council for the Blind

and several white-supremacist groups. A majority of those attending the meeting were senior citizens and disabled persons concerned that proposed federal budget cuts would spell the end of Dial-a-ride, a subsidized transportation program.

But they were relieved to hear from Levin that the program would be continued.

In a meeting with Livonia Mayor Edward McNamara earlier in the day, Levin learned of the Michigan Court of Appeals ruling last week that special driver's license and title transfer fees charged motorists in Wayne, Oakland and Macomb counties are legal. McNamara is a member of the Southeastern Michigan Transportation Authority. The license fees help fund Dial-a-ride programs.

Reagan's proposed budget cuts, taxes and defense spending dominated most of the discussion.

LEVIN TOLD the audience he supports spending cuts but not "in the same mix as the administration."

"The President has proposed cuts that are useful but others are terribly disproportionate. Michigan's unemployment rate is the highest in the nation and he (Reagan) has asked for cuts in four major unemployment programs. At the same time he leaves the tobacco farmers' subsidy untouched. And he's asking for only an 11 percent cut in water projects that benefit the southwest."

"I can't in good conscience say these cuts are equitable for people in Michigan. I want everyone to tighten their

belts — fairly," Levin said. Levin said although he endorses tax cuts, he doesn't support Reagan's program because it is "unfairly skewed" to give high-income persons a disproportionate tax break.

AFTER ACCEPTING hundreds of letters from readers who wrote to this newspaper in support of Observer & Eccentric columnist Steve Barnaby's oil boycott, Levin told audience members he opposes decontrol of natural gas and oil.

He said oil prices have been artificially created and have resulted in "trillions of dollars in windfall profits" for oil companies.

On the auto industry, Levin said he favors temporary measures to curb imports.

Report fails to fluster officials

(Continued from Page 1A)

ple of years, as inflation, high interest rates and a poor economy have taken their toll.

For example, there were only 50 housing starts in Canton during 1980, compared to 1,577 in 1978.

So far this year, Canton's building department has received only one request for a permit to build a single-family home.

Other factors which will could affect Canton's growth are several unresolved issues, including the economy, the resolution of the farmland preservation is-

sue and availability of sewer and water lines.

MEANWHILE, several Canton officials point out that the projection is just that — a projection.

"The economy can have a tremendous impact," said Flodin. "I think it (the study) will impact on some. Farmland preservation — it isn't necessarily the preservation of open space, but the preservation of food."

Township Planner James Kosteva said he hasn't had a chance to read the report. But he added that the prediction doesn't erase the need for long-range

planning. "Their prediction doesn't inherently reduce the need for Canton to plan for the future in a variety of land uses," said Kosteva.

Supervisor James Poole termed the prediction "presumptuous."

"They don't know if there is going to be an economic recovery or not," said Poole.

"The economists say it will take a

long time for the economy to turn around," said Trustee Carol Bodenmiller, the township's delegate to SEMCOG who also serves on the farmland preservation committee.

Mrs. Bodenmiller said the slowdown in Canton's growth could take pressure off the farmland preservation issue, "which would be good."

"If we could get industry going, we could bring more jobs," she added.

JEFFREY H. FORREST, D.D.S., P.C.
Family Dentistry

Orangelawn Professional Center

Dear Dr. Forrest,
How can I have 8 cavities in only 4 teeth? I am confused.
Doil M. Bucca

Dear Doil,
Each of our teeth has five surfaces subject to decay or fracture. When a filling is done a separate preparation is necessary for the silver to be placed in the affected area. The fee for a silver filling is customarily based on the number of surfaces involved, the restorative materials used, and the complexity of the restoration.

Sincerely,
Jeffrey H. Forrest M.D.

10535 Farmington Road • Livonia
(Between Plymouth Rd. and Orangelawn) • 525-7616

Shower the Bride and Groom with Gifts for the Bath

Towels by Fieldcrest Ames and Avanti

- Fancy toilet seats
- Bath Scales • Hampers
- Vanity cabinets and tops
- Decorative wall and counter accessories
- Medicine cabinets and mirrors
- Bath rugs and carpeting
- Colorful soaps
- Decorative faucets
- Shower curtains and more!

Long's
fancy bath boutique

190 E. Main Street, Northville
Mich. 48167 • (313) 349-0373
Monday thru Thursday 9-5:30
Friday 9-9 Saturday 9-5

one of the largest and most complete bath shops in the state

pizza!pizza!

Two great pizzas!
One low price!

Buy any size pizza!pizza! with this coupon at one low price!

COUPON

Carry out only
EXPIRES
3-25-81

Available in Small, Medium & Large

Good at all participating locations

One coupon per customer at participating locations only

Cozy Dining by Sugar Hill Furniture

Our Heart's in the right place...

Because this dining room group is real Luv. Our Luv Group, featuring picturesque heart cut-outs, includes a space saving drop leaf table, two 48" benches, and a one-piece 36" hutch — all in sturdy matching 2" solid pine! Cozy and just right for today's smaller apartments, condominiums and homes, you'll love the decorative versatility and rustic beauty of Luv. This unique grouping is now at Sugar Hill's specially affordable prices.

SALE

48" Drop Leaf Table... \$599
Two 48" Benches... \$299
36" Hutch... \$299

Schrader's
Home Furnishings

"Quality Furnishings since 1907"

Mon.-Tues.-Sat. 9 to 6; Thurs. & Fri. 9 to 9; Closed Wednesday
111 N. Center (Sheldon) Northville 349-1838

Our talented salespersons, each a professional interior designer, gladly assist you as a complimentary service.

Michigan's first Drexel Heritage store

Ray Interiors

33300 Slocum Dr., Farmington 476-7272
3601 Plymouth Rd., Ann Arbor 995-9095

TIMEX
AFTER-WARRANTY SERVICE

NORTHVILLE
Watch & Clock Shop

132 W. DUNLAP
(1 Blk. North of Main Street)
NORTHVILLE
349-4938

Family Discount Drugs

Package Liquor Dealer

WHILE THEY LAST
Ladies Gorgeous \$40.00 Perms
\$17.50 with this ad

We also do wet sets

Gentlemen WELCOME!
HAIR CUT SPECIAL
\$10.00

Shampoo - Blow Dry - Style

EXPRESSIONS Hair Salon

15369 Newburgh Rd. Salon
N.W. Corner of 9 Mile • Livonia
464-2270 Open 6 Days

30% OFF ALL WALLPAPER

No Freight Charge

50¢ per roll added to all orders less than Full Case (24 rolls)

Call in any pattern from any book or visit our excellent wallpaper department

Open 9-6 Mon.-Sat., 11-3 Sun.

BLACK'S HARDWARE

117 E. Main Street
Northville
349-2323

A GREAT DANCE EXERCISE PROGRAM FOR FITNESS

DANCE EXERCISE ENTERDISE

FREE DEMONSTRATION PARTICIPATION CLASS

MARCH 16th 10:00 A.M. & 1:00 P.M.

CLASSES BEGIN MARCH 18 thru APRIL 13

at
Rose Shores Racquet Club, 41677 Ford Road
(West of I-275) Canton

Mon. & Wed. 9:30 a.m. - 11:30 a.m. & 1:00 p.m.
128 includes use of Spa Facilities & Babysitting

For Information Call
977-7224

HOME & GARDEN HAS A PEEL!

Watch for it!
Monday, April 13

Step up to Savings

19⁹⁹
Reg. 25.99

B&D Stow-a-way Step Stool

Folds to a slim one inch. Tested up to 900 lbs! Has non-skid feet and a almond-color epoxy finish. 9600

Associated Foot Specialists

35000 Ford Rd. WESTLAND

Providing All Phases of **FOOT CARE** in this area for over 25 years

All Medical Insurance Honored
Alan Nickamin, D.P.M.

721-0703

LIVONIA True Value HARDWARE

5 Mile at Farmington
GA2-1155 - 937-1611

OPEN DAILY 9 a.m. - 9 p.m. SUNDAY 10 a.m. - 3 p.m.

MAYBELLINE GREAT LASH MASCARA FREE REFILL \$1.66	MAYBELLINE MATTE SHADOWS COLORS THAT CLING \$1.29	MAYBELLINE NEW BLOOMING COLORS MULTI-PAK SHADOW COLLECTIONS BOUTIQUE \$1.93
MAYBELLINE MANICURE NAIL COLOR 95¢	MAYBELLINE MINI KISSING STICK 77¢	MAYBELLINE ULTRA SLIM LIPSTICK \$1.77
MONSTER OR PALS MULTIPLE VITAMINS • REGULAR • IRON 100's \$2.66	BLISTEX OR BLISTIK NOW IN MINT AND BERRY FLAVORS 49¢	BENYLIN DM COUGH SYRUP NON NARCOTIC QUIETS COUGHING 4 oz. \$1.55
GELUSIL ANTACID ANTI-GAS 12 oz. Liquid \$2.14 100 Tablets \$2.34	L'OREAL PREFERENCE HAIR COLOR KIT \$2.44	L'OREAL ULTRA RICH SHAMPOO OR CONDITIONER 16 oz. \$1.39

Discount Prices EVERY DAY of the Week

1400 SHELDON ROAD-CORNER ANN ARBOR ROAD-PLYMOUTH TOWNSHIP
DISCOUNT PRESCRIPTIONS

HOURS: Open Monday Saturday 9 A.M. - 10 P.M. Sunday 11 A.M. - 6 P.M.
PHONE 453-5807 or 453-5820
BEER WINE OR CHAMPAGNE PACKAGE LIQUOR DEALER

Resident is amongst our newest citizens

By CRAIG PIECHURA

On her first day as an American citizen, Carrie Maier found it easier to tell what she didn't like about Colombia than what she liked about the United States.

Miss Maier, 9, of Farmington Hills, took the oath Monday afternoon in the Federal Building in downtown Detroit along with 48 other former foreigners.

A TV news crew and reporters and photographers from two newspapers were there to record the event and ask Carrie what she liked about her new nationality.

"They can't tell me to go back to Colombia," Miss Maier said. "I want to be a United States citizen. I don't want to be a Colombian citizen. I don't like it there. They were mean to me. Every day they made me clean the room, wash dishes and cook. I had to take care of the whole house."

"You see I was adopted twice and I'm glad I got the mom and dad I got now."

Her parents, Alan and Maureen Maier, are pretty pleased with the arrangement too. The Maiers confirm Carrie's tale of a history of hardship in South America.

Carrie lived in an orphanage from the age of 1 until she was adopted by a Colombian family when she was 5. But it was back to the orphanage when a social worker found the family was using Carrie to do domestic work both at home and at their store.

After completing an extensive screening process, the Maiers flew to Bogota in October 1979 to accompany their daughter home for good.

THAT'S WHY the concept of "home" is so important to Carrie. Today, less than two years later, Carrie speaks English effortlessly and is even having trouble communicating in Spanish with a classmate, Gabriel Borda, who hails from Argentina.

All 28 of Carrie's classmates were on hand Monday for the swearing-in ceremony in the courtroom of U.S. District Judge Patricia Boyle. The students waved tiny flags, furnished by the Daughters of the American Revolution Chapter and 17 of the students even got to sit in the jury box during the proceedings.

The verdict from Jennie Fitzgerald, a classmate of Carrie's at Larkshire Elementary, was that the experience

was worthwhile. Before the citizenship ceremony, Jennie said Carrie was just another kid in class. Now she's something special.

"I learned that some things are important to know instead of just thinking about yourself," Miss Fitzgerald said. "Like how Carrie became an American citizen."

Sharing her big day with 28 classmates was the nicest part about becoming a citizen, Carrie said. Of course being on TV didn't hurt either.

Also in the contingent was Carrie's brother, Ted, 14, and Victoria, 13, Car-

rie's third-grade teacher, Ariene Schieber, the school principal and two bilingual teachers from the Farmington School District.

WITH ALL the spectators there to see Carrie, there almost wasn't room for the 48 other new citizens.

The breakdown, by country, of the other 48 immigrants was eight from Yemen, six from India, four from Poland, four from Iraq, three from Great Britain, three from Korea, two from Jordan, two from Lebanon, two from Jamaica, and two from Germany and

one each from Colombia, Brazil, Canada, Czechoslovakia, Hong Kong, Japan, Palestine, the Netherlands, Romania and Syria.

Eight of the 49 new citizens were children.

Richie LaBret, 6, who was born in Seoul, Korea, had a tough time repeating words like "sovereignty" in the oath. Richie is the adopted son of Gary and Carol LaBret of Plymouth. Mr. LaBret works as a Wayne County Prosecutor and since adopting Richie the couple had two other children.

Because he knew Judge Boyle, the proud father was able to pose his son behind the judge's bench for pictures. The judge gladly complied, but Richie was a little bewildered about the whole business.

Richie was tight-lipped about what he would do now that he's an American citizen. But, with his mother's prodding, let on that he wanted to be a policeman and "get robbers."

The judge departed from the official text to tell the new citizens that this country welcomes them by "celebrating your diversity and our oneness."



Richie LaBret, 5, all-American citizen from Plymouth, got to stand behind the bench of U.S. District Judge Patricia Boyle after he and 48 other former foreigners took the oath.

GORMAN'S
103 DREXEL • HERITAGE
ROOM SETTINGS
GORMAN'S
FAIRLANE TROY

Your Best Buy
CLASS RINGS

Your choice of style, design and stone.
2-4 week delivery
\$30 Deposit
Willsie
Cap and Gown Company
27521 Schoolcraft • Livonia
421-8810 Hours: 8:30-4:00
Mon.-Fri.

Laurel
FURNITURE
DIRECTOR'S CHAIR
The Price
\$22.88

100% Polyester vat-dyed fabric. White baked enamel steel frames. 3 colors
584 Ann Arbor Trail
Plymouth 453-4700
Open Daily 9:30-6 pm
Thurs. & Fri. til 9:00 pm

P-12
27% off
WALLPAPER
Call in any pattern from any book.
NO FREIGHT CHARGE
NO DELIVERY CHARGE • PAY WHEN DELIVERED

BLOOMFIELD 851-7110	ANN ARBOR 662-1140	FLINT 787-3050
GROSSE PTE. 866-4050	FARMINGTON 474-1780	ROYAL OAK 544-3800
TROY 524-2200	LIVONIA 522-7500	OTHER AREAS 800-482-2488

Post Wallcovering Distributors, Inc.
50 Cents Per Roll Added To All Orders Less Than Full Case (24 Rolls)
(This May Reduce The Effective Discount Rate)
No Returns On Unused Wallpaper
HOURS MON.-FRI. 9:00 A.M. to 5:00 P.M.

Free Hearing Tests Set For Senior Citizens

Hearing Aid Centers Thurs., March 12th through Thurs., March 19th, 9 a.m. to 5 p.m. Factory trained hearing aid specialists will be at the offices listed below to perform the test.

Anyone who has trouble hearing is welcome to have a test using our modern electronic equipment to determine if this loss is one which may be helped. Diagrams showing how the ear works and some of the causes of hearing loss will be available. Everyone should have a hearing test at least once a year if there is any trouble at all hearing clearly. Even people now wearing a hearing aid or those who have been told nothing could be done for them should have a hearing test and find out about the current methods of hearing correction.

Call for an appt. so you don't have to wait.

BELTONE HEARING AID SERVICE

Available Only at these offices below

WEST 22054 MICHIGAN AVE. DEARBORN 561-3604	LIVONIA WONDERLAND CENTER 261-2630	DETROIT 19236 GRAND RIVER KE 7-9880
--	---	--

WE ARE PROVIDERS OF HEARING AIDS UNDER BLUE CROSS MICHIGAN HEARING AID PROGRAM, ALL FEDERAL AND STATE PROGRAMS, UNION INSURANCE AND MEDICAID PROGRAMS.

WE BUY DIAMONDS
STOCK LIQUIDATION SALE
OFFER ENDS 3/26/81

- ALL DIAMOND JEWELRY 30-50% OFF
- NEW GOLD CHAIN NOW ONLY 18.90 PER GRAM
- ALL 14KT & 18KT MOUNTINGS 30-50% OFF
- ALL GIFTWARE 30% OFF
- ALL COSTUME JEWELRY 30% OFF
- ALL MENS JEWELRY 30% OFF
- ALL WATCHES 30-50% OFF

SEKO-BULOVA-OMEGA-SPEIDEL-PULSAR
WATCH FOR OUR NEW STORE
OPENING IN BIRMINGHAM SOON!

Diamond Jewelers
1638 MIDDLEBELT
BETWEEN 5 & 6 MILE IN TERRENCE CORNERS
LAWAY - VISA - MASTER CARD
WE BUY OLD GOLD

EXPERT REPAIRS & APPRAISALS
HOURS: MON.-SAT. 10-6, THUR. 10-8
525-4165
Keepsake
Registered Diamond Rings

AT
Best
carpets & area rugs

RIGHT NOW!
Markdowns on...
every oriental design
every carpet
every contemporary rug
every wall-hanging
every handmade oriental rug
every braided rug

No matter what your needs for rugs or carpets you can save right now during the big BEST sale. All the good things are marked down. Sale ends March 28.

Best
carpets & area rugs
Woodward at 11^{1/2} Mile
543-5300

STOREWIDE SALE
Excellence In Style & Craftsmanship Since 1949

We've got a touch of Spring... Look out world, here we come!

SAIL BOATS
POWER BOATS • SKI BOATS
PONTOONS • DECK BOATS
PADDLE BOATS • CANOES

Ships Ahoy... Boat Show
Friday, March 13 — Sunday, March 22
WIN \$2500 TOWARD THE PURCHASE OF A BOAT FROM THESE DEALERS:
Fortune Marine, Inc. • Sun & Ski Marina • King Marine, Inc.
Bloomfield Beach & Boat • Pine Lake Marina • The Boatery • Sun & Sail

Enjoy the World of Action... Twelve Oaks Mall
Located on Novi Rd., north off 96 Strollers available Hours are 10:00 a.m.-9:00 p.m. Mon.-Sat. Sun. Noon-5:00 p.m.

Group home numbers spark controversy

(Continued from Page 1A)

According to Poole, the flood of calls which have been pouring into Township Hall has kept employees busy for at least eight hours each day. "Everyone who lives in Canton has called," said Clerk John Flodin. Township officials say they lack information to give to residents.

POOLE HAS ASKED DSS, which has responsibility for screening applications and licensing homes, to submit detailed information on the types and numbers of homes planned for Canton. "It's totally disorganized," Poole said of the state's record-keeping on

group homes. "I don't think anyone is trying to cover up. Everyone has been extremely helpful in their own limited responsibilities."

Potential group homes are identified by either a state institution or private investor. The home is then purchased and then leased to the state. The institution contracts with a private corporation for day-to-day operations in the home.

DSS screens the application and gives final licensing approval.

Poole points to a bureaucratic record-keeping system that makes getting information on group homes a time-consuming task. Consider the fol-

lowing:

- The township clerk's office receives notice of a group home application shortly after it has been submitted. But Flodin said the notice does not include the home's type — mentally retarded, mentally ill, etc. The township usually receives notice of an application withdrawal after a time lag of about four weeks. Flodin has received no notification of application approvals.

- At DSS, the most recent computer printout list of approved homes is dated January. A variety of licensing consultants, who screen proposed Canton homes, know individually about

their own pending cases.

Two divisions within DSS license homes for adults and mentally retarded children.

- The three institutions which place residents in Canton know individually about their own proposed homes.

TO PIECE TOGETHER a list of approved and pending homes in Canton, the Observer contacted the township, DSS and all three institutions. That list includes:

- A pending application for a home for the mentally ill at 44450 Forest Trails Drive. Sponsor is Northville Regional Psychiatric Hospital. Not re-

lected in township records.

- A pending application for a home for the mentally ill at 6492 Raintree Court. Sponsor is Northville Regional Psychiatric Hospital. Not reflected in township records.

- A pending application for a home for the mentally retarded at 43015 Saxony. Sponsor is the Northville Residential Training Center (NRTC).

- A pending application for a home for the mentally retarded at 43108 Hanford. Sponsor is NRTC.

- A pending application for a home for the mentally retarded at 3605 Canton Center. Sponsor is NRTC.

- An approved application for a home for the mentally retarded at 1993 Marlowe. Sponsor is NRTC.

- An approved and functioning home for the mentally retarded at 2337 Roundtable. Sponsoring institution is NRTC.

- An approved home for the mentally retarded at 1675 Haggerty. Sponsoring institution is NRTC.

- An approved home for the mentally retarded at 41600 Warren. Sponsoring institution is NRTC.

- A functioning home for mentally retarded children on Maben. Sponsoring institution is Plymouth Center for Human Development.

- A pending application for a home for the mentally ill at 47126 Cherry Hill. New construction.

- A proposal has been submitted by the Northville Regional Psychiatric Hospital for a home at 44137 Sheridan. However, a formal application has not been filed.

- A proposal has been submitted to DSS by the Northville Regional Psychiatric Hospital for a home at 51260 Murray Hill. A formal application has not been filed.

- Applications for three group homes have been withdrawn. They include a proposed home for the mentally ill at 8503 Manington, a proposed home at 43825 Simsbury and a proposed home on Herbes.

St. Patrick's Day Queen

Redford teen tapped for royal role

By LYNN ORR

With her red hair, blue eyes and fair complexion, no one questions Anne Lezotte's Irish heritage despite her French surname.

The 18-year-old Redford Union High senior will reign as queen in the St. Patrick's Day Parade at 2 p.m. beginning at Woodward Avenue in downtown Detroit Sunday.

Miss Lezotte's surname comes from her French-German father, but she has her Irish heritage, which allowed her to compete for the queen's title in the Royal Order of Hibernians' contest to select a queen and court for the parade.

Criteria include a relative who is a member of the Hibernian order and an Irish grandparent.

Miss Lezotte's grandmother, Sara

Regan Ross, now 82, immigrated to the U.S. as a child in the early 1900s after her mother died and her father decided to go to New York. He raised money to bring over his children one-by-one, and the family moved to Detroit.

Miss Lezotte's interest in her Irish heritage was piqued by her grandmother's stories of the old country and her mother's membership in the Rosemary Kennedy chapter of the Hibernians.

Her parents, William and Sarah Lezotte, have lived in Redford for 22 years. The family includes nine children, but Anne is the only redhead.

life, "You've got to be Irish," said Miss Lezotte.

The queen, gowned in an emerald-green cape, and her court, Eileen McNamara of Dearborn Heights and Sharon Foley of Warren, in white capes, have already appeared at party to raise funds to defray the cost of the parade, in which they will ride on a float. The court also will be appearing in a mass on St. Patrick's Day and at other Hibernian halls in the area for parties.

The Redford Union High marching band, under the direction of Lincoln Naumoff, also will be in the parade.

"PEOPLE HAVE said to me all my

Foster care meeting set

(Continued from Page 1A)

According to Ms. Sheldon, mentally ill clients who are placed in community homes have no criminal records or no history of violence.

"The people we're placing are no longer actively mentally ill," she said. "They need supervision and re-training in survival skills, such as shopping. They are real human beings."

According to experts in the field, residents of homes for the retarded and mentally ill are carefully screened pri-

or to placement in residential communities.

Ms. Murrell said DSS approves group home applications only for one specific use. Approval of a home for the mentally retarded, for example, precludes use of the home for the mentally ill.

She also assures residents that the DSS program is not connected in any way with a program of the Michigan Department of Corrections for neighborhood half-way houses for parolees.

None of those type homes have been proposed for Canton.

SURPRISE SOMEONE IRISH!
... or not so Irish

GOURMET BALLOONS
661-9331

GLITTERING BALLOON(S) with MESSAGE (shipped nationwide)

UNIQUE BOUQUETS with GIFT BASKET & SWEETS (delivered locally)

— party centerpieces available —

PERSONAL INJURY LAWYERS

We specialize in accident and personal injury cases

- Auto Accidents
- No Fault Accidents (against your insurance company)
- Job Injury Cases (Workers Compensation)
- Hospital Negligence
- Product Liability (Injury from defective product)
- Aviation Accidents
- Social Security
- Federal Injury Claims
- Medical Malpractice
- Also: General Practice, Domestic Relations, Criminal, Wills, Probate

No Fee for Initial Consultation

Call for an appointment at our Plymouth or Southfield Office **455-4250**

JOHN F. VOS III
Sommers, Schwartz, Silver & Schwartz P.C.
Over 40 lawyers associated with firm.

LAST CHANCE TO GET
SUBSCRIPTION T.V. FOR

ON 1/2 OFF

That's right! With your existing antenna, regular installation is 1/2 price, plus a refundable deposit of \$50.00.

FREE INSTALLATION of "ON" TV with purchase of any Channel Master Rotor Antenna System listed below

Outer Suburban	Deep Fringe	Deeper Fringe	Deepest Fringe
\$139 ⁹⁵	\$159 ⁹⁵	\$189 ⁹⁵	\$229 ⁹⁵

Includes Stainless Steel Chimney Mount or Tripod
No Extra Charge for 2 Story Homes
*** 1 YEAR WARRANTY ON INSTALLATION**

Don-Lot's T. V.
Call Today **427-3910 or 427-3911**

FREE CONTOUR ANALYSIS EXAMINATION FOR VICTIMS OF CHRONIC OR ACUTE PAIN

A free Contour Analysis examination is being offered for people with acute or chronic pain by the chiropractic office listed below. People who suffer with backache, bursitis, arthritis, neuralgia, nerve pain, neck pain, muscle pain, bone pain, etc., are invited to receive this free examination.

Contour Analysis enables taking a three-dimensional picture (called Moire photography) of the topography of the surface of the spine to detect spinal stress deviations. This analysis will be correlated with leg deficiency, patient symptomatology, and levels of spinal tenderness. An analysis of this type can reveal such things as normal and abnormal stress patterns, spinal curvature, muscle spasms, muscle imbalance, spinal distortion, and scoliosis. This analysis, including consultation with the doctor is being offered to the public at no charge for the next 30 days. Anyone wishing to receive this free examination may telephone for information or an appointment.

Dr. Walter S. Gross
Chiropractic Physician

27620 Five Mile Road
Livonia, Michigan 48154 **427-6333**

Please call for an appointment and bring a copy of this announcement with you. ©CM

Wedding Invitations
Bridal Accessories
Hallmark Cards

McDEVITT Hallmark
478-0707

EASTLAND MALL 8 Mile at Ford
NORTHWOOD CENTER 71 Mile at Woodward

UNIVERSAL MALL 12 Mile at Dequindre
7 FARMINGTON CENTER 7 Mile at Farmington
Livonia

Do-It-Yourself Center
OFFERING A COMPLETE LINE OF

HELL
HEATING & COOLING PRODUCTS

THURSDAY-FRIDAY-SATURDAY SPECIAL
LOCHINVAR KTN WATER HEATERS

30 Gal. \$146⁵⁰ (List \$165.00)
40 Gal. \$151⁰⁰ (List \$175.50)
Installation available \$99.00

- Air Conditioning
- Furnaces
- Humidifiers
- Electric Air Cleaners
- Replacement Parts
- Service & Repair

FURNACE WORKS
37460 Five Mile at Newburgh
Livonia • 464-6462

(COUPON)

HAIRCUT
\$5 (Long or tinted Hair slightly extra) (Expires 3/19/81)

HEATWAVE
\$25 Complete with haircut (Long or tinted hair slightly extra) (Expires 3/19/81)

SHAKLEE PRODUCTS at Distributor Cost

"Shear Delight" BEAUTY SALON
32669 WARREN (at Venoy)-GARDEN CITY
GIRL SCOUT COOKIES AVAILABLE
REDKEN SHAKLEE
261-1090

SPRING CLEAN-UP VALUES

CLOSE-OUT 50% OFF

UNFINISHED FURNITURE	SELECTED GIFT WARE
SELECTED WALLPAPERS IN STOCK	OLD WORLD SHELIVING
CLOCKS	PICTURES

- LANDMARK
- WESTMINSTER CHIME
- VERICHRON REGULATOR

WHILE QUANTITIES LAST

PEASE PAINT & WALLPAPER CO.
570 MAIN STREET
PLYMOUTH • 453-5100
MON. THRU FRI. 9-9
SAT. 9-5

SALE ENDS 3-18-81

Try Our Flavor Packed **POT ROASTS** on Sale!!

7-BONE CHUCK \$1.69 lb.

ROUND BONE or ENGLISH CUT \$2.09 lb.

Blade Cut **CHUCK** \$1.49 lb.

FREEZER BEEF
Beef \$1.59 lb. Beef Steak \$2.49 lb. Hind Loin

SUPER SAUSAGE SALE
Our Own Made Fresh Daily

Fresh **KIELBASA** Italian **SAUSAGE** **BREAKFAST LINKS** \$1.99 lb.

Smoked Kielbasa.....\$2.29 lb.
Expires 3-14-81

WESTLAND MEATS, INC.
featuring Alexander & Horning products
Westland Center **421-2730**
Mon. & Thurs. 9:30-8 Tues. & Wed. 9:30-6 Fri. & Sat. 9:30-9

The President's fast cuts won't halt inflation—Shapiro

By TIM RICHARD

President Reagan's proposed tax cuts "are too large and come too soon" to give the United States a credible anti-inflation policy, according to Harold Shapiro's economic forecast.

Shapiro, one of the nation's best known economic forecasters and since 1980 president of the University of Michigan, told a Schoolcraft College audience "Reagan may not have gone far enough," however, in making spending cuts.

Shapiro saw the three main components of Reagan's policy as spending cuts, tax cuts and defense boosts and called each component acceptable. All are due for implementation Oct. 1.

"But if you don't time them somewhat differently," he warned, "they will not achieve the desired results — reviving the economy in the most beneficial way."



HAROLD SHAPIRO
Space out tax cuts

THE 10th president of the University of Michigan, Shapiro, 45, has been on a fast track since he joined the economics department faculty in 1964.

He became department chairman in 1976, dean of the liberal arts school in 1978 and president last year. Meanwhile, his work in economic forecasting has brought him national attention.

He spoke without fee to an audience of 200 in Schoolcraft's cultural and public affairs series.

"Inflation is our most important problem, in the sense that we're not going to solve unemployment until we solve the inflation problem," he said.

"Continuing inflation comes from

only one source... federal government deficits. OPEC (oil price increases) cannot cause continuing inflation. It can cause a once-and-for-all inflation."

Shapiro said he would have exempted no area of federal spending in looking for ways to cut expenses, even social security.

BUT BEFORE instituting three personal income tax cuts of 10 percent a year beginning with fiscal 1982 on Oct. 1, he would prefer to "see if Congress has the will to control the budget."

"Inflation is an economic symptom of something else. Continuing inflation is a political problem. Congress hasn't

had the will to increase taxes and decide which of the conflicting (spending) interests will be denied."

Assuring Congress has the courage to hold down the budget deficits should take only 12-15 months, Shapiro said. He cited eastern European economies which, after World War I, suffered from inflations of 12 percent a month compared to the United States' 12 percent a year.

"I've studied those economies. Those inflations came to a stop within a year when it became apparent someone was making (fighting) inflation a priority."

"I think we can get it down (to 5 or 6 percent) only if we can get people to believe it's a priority... to wind down people's expectations. It's critically important that we adopt an anti-inflation program."

He would start tax cuts in the business sector because American savings and investment have been so low.

Without addressing the need for defense increases, Shapiro urged a slower approach to boosting that share of the budget. "Even if one is a hawk on defense, there are other things besides hardware you need — a strong economy and social solidarity."

MICHIGAN'S economic future is hard to forecast in the next 10 years, he said.

"The auto industry will revive. The

auto companies will not move away. But the auto industry won't provide increased employment in this state."

Growth will come from small- to medium-sized companies which are labor intensive and employ high technology.

Despite much talk about diversifying Michigan's economy since 1953, "nothing has been galvanized."

In answer to a question, Shapiro said Reagan's move to deregulate natural gas will help Michigan, which must import most of its energy. Deregulation will assure Michigan ample supplies and follows the principle that "he who has the money gets the energy."

On the University of Michigan's own future, Shapiro predicted a shrinkage of enrollment on the Ann Arbor campus from the current 35,000 to perhaps 30,000, adding, "That's not all bad... Programs where we don't do well, we'll just get out. Inside every crisis there's an opportunity."

While the shrinkage in the number of 18-22-year-olds during the 1980s will hurt colleges, Shapiro said the decade ahead will also see a great growth in the 25-40 prime working age group. He called that age group, along with "the capacity of the American economy to adapt to change," two of the nation's most important strengths in the decade ahead.



Sending a message

U.S. Sen. Carl Levin, D-Mich., was presented with more than 200 letters from readers by Observer columnist Steve Barnaby at a recent Livonia town hall meeting. The letters were from readers who support a boycott of oil companies because of the high price of gasoline. For more comment and responses, see today's editorial page. (Staff photo)

Headlee says quitting fine for lawmakers

Insurance executive Richard Headlee, in a talk to the area chambers of commerce in Plymouth, says it might be best if State Reps. Bobby Crim and William Ryan made good on their threats to quit their legislative jobs.

While speaking at the Plymouth Hilton Inn, Headlee told the gathering that it would be best if House Speaker Crimm, D-Davison, and Ryan, D-Detroit, "go ahead and quit."

Headlee is chairman of the board of Alexander Hamilton Insurance Corp. in Farmington Hills and author of the tax limitation amendment now part of the Michigan Constitution.

"In the same week Reps. Crim and Ryan have threatened to quit unless the State Chamber of Commerce stops urging them to cut taxes and control state spending," Headlee told a regional meeting of chambers of commerce in Plymouth last Friday. "The state chamber has been urging state government to get off the back of business so we can create jobs."

For 14 years, former Speaker Ryan has been leading the UAW and AFL-

CIO charge in Lansing toward state bankruptcy, claimed Headlee, and for 10 years Crim has been trying to change Michigan into a protectorate for the Michigan Education Association (teachers union) and other free-spending special interest groups prospering at the public trough.

"Also during the same period, taxes in Michigan from all sources have increased at record levels to support the outlandish growth of state government. Today there are more than 159,000 people drawing salaries and fringe benefits from state taxpayers."

"And today Michigan's business climate ranks dead last in comparison to every other state in the continental U.S."

THE ANTI-BUSINESS attitude and free spending practices of certain leaders of the Michigan Legislature are two of the main reasons why Michigan has the highest unemployment rate in the U.S. today, Headlee said.

"What kind of quality of life can we have when we are driving people out of the state by the thousands?"

Vic Tanny Celebrates!



The all-new 2 million dollar Plymouth Vic Tanny Health & Racquet Club

Join the Grand Opening Celebration in Plymouth on March 20, 21 & 22nd
Enjoy all these great facilities...7 days a week!

- Professional racquetball/handball courts
- Banked indoor 1/14th mile jogging track
- Aerobic exercise dance class area
- Private showers and dressing rooms
- Indoor heated olympic-size pool
- Finnish rock sauna
- Separate men's and women's exercise areas
- Turkish steam bath
- Hydro whirlpool and more!

FINAL DAYS! 50% OFF

Join now and get 50% off monthly dues for as long as you remain a Vic Tanny member



JOIN NOW...HELP YOURSELF AND HELP EASTER SEALS!

Vic Tanny joins WDIV's Mort Crim and Detroit Lion Gary Danielson (pictured with 1981 poster child Megan McClanahan) in supporting this year's Easter Seals campaign. Join now and part of the enrollment fee goes to Easter Seals. See Gary during the grand opening celebration. Watch him join host Mort Crim on the Easter Seals telethon, March 28, on WDIV.

FREE Workout Attire

Join any Vic Tanny club now and get free workout attire! Hurry-limited time for this special offer!

Men...Women Call Now!

VIC TANNY

40700 Ann Arbor Rd.
Conveniently located between Haggerty Rd. and I-275
459-8890

Rite Carpet

SAVE 30%-60% Famous Maker REMNANTS & ROLL ENDS

BRIGHTON Brighton Mail 227-1314
LIVONIA 7 Mile and Middlebelt Across from Livonia Mall 476-8360
Mon., Thurs., Fri. 9-9 Tues., Wed., Sat. 9-6

Five Nice USED PIANOS \$495 to \$1095
Weaver Music 383-2770

It's Time To Think Spring
CLYDE SMITH'S IS NOW OPEN

Large Selection of HANGING BASKETS

4 1/2" Potted MUMS \$1.98
6 1/2"\$3.98

Plus
Rieger Begonias.....4 1/2" pot.....\$2.49
African Violets.....\$1.89
Cinerarias.....6" pot.....\$4.95
Pocket Book Plant.....6" pot.....\$4.95
Kalanchoes.....4 1/2" pot.....\$1.89
10" Fern.....\$7.95
Dwarf Shamrock.....98¢
Shamrock.....4 1/2" pot.....\$1.89

10% OFF on Flower & Vegetable SEEDS
With This Coupon (Good thru 3/31/81)

CLYDE SMITH & SONS CENTENNIAL Farm MARKET
8000 Newburgh Road
Open 7 Days 9 a.m. - 5 p.m.

WOODLAND MEDICAL CENTERS

WOODLAND = DIAGNOSIS + TREATMENT + CARE + CONCERN

Diagnosis and treatment are available in specialized areas... person to person.

General and internal medicine	Cardiology	heart and coronary disorders
Pediatric and adolescent medicine	Dermatology	skin disorders
Hematology	Allergy and immunology	reaction to environmental substances
Oncology	Physical medicine and rehabilitation	
Obstetrics and Gynecology	Pulmonary diseases	
Gastroenterology	Mental health	
Ophthalmology	Occupational and industrial medicine	
Diabetes	Surgical specialties	general, orthopedic, vascular, and others
Podiatry	Urology	
Rheumatology	Neurology	
Endocrinology		

Physicians and surgeons in these specialties are aided by the newest technology and equipment. Woodland represents superior medical care... person to person.

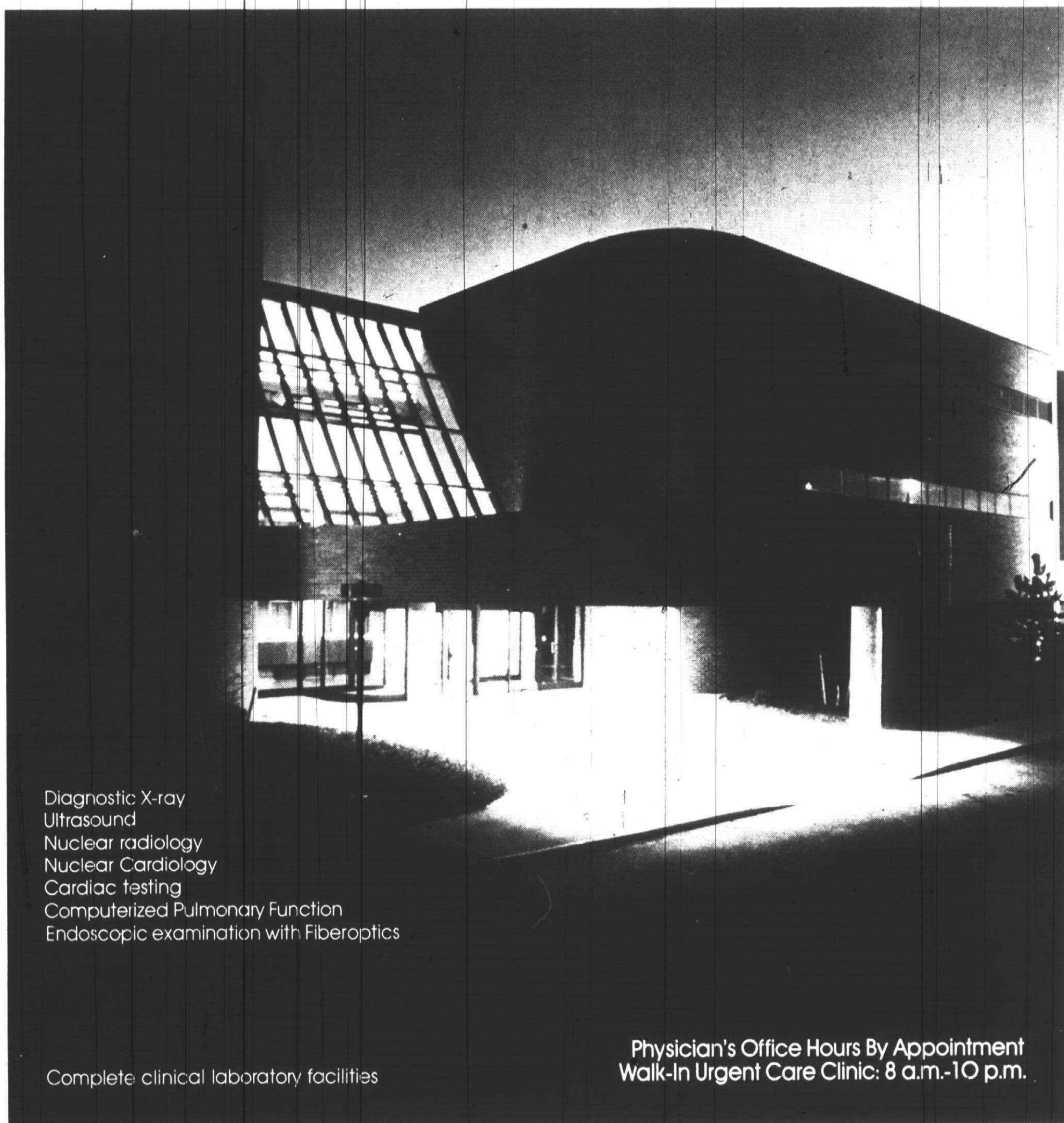

Diagnostic X-ray
 Ultrasound
 Nuclear radiology
 Nuclear Cardiology
 Cardiac testing
 Computerized Pulmonary Function
 Endoscopic examination with Fiberoptics

Complete clinical laboratory facilities

Physician's Office Hours By Appointment
 Walk-In Urgent Care Clinic: 8 a.m.-10 p.m.

Paul Aronson, M.D.
 Internal Medicine, Hematology,
 Oncology

Harry Balberor, M.D.
 Internal Medicine

Abraham Blumer, M.D.
 Obstetrics, Gynecology

Henry Bystowski, M.D.
 Internal Medicine, Rheumatology

F. N. Burt, M.D.
 Vascular Surgery

Wyman C. C. Cole, M.D.
 Pediatrics, Adolescent Medicine

Harold Daitch, M.D.
 Radiology

H. D. Dave, M.D.
 Internal Medicine

Jeffrey Dembs, M.D.
 Pediatrics, Adolescent Medicine

Thomas Dittkoff, M.D.
 Orthopedic Surgery

Elizabeth Edmond, M.D.
 Physical Medicine

Leopoldo Eisenberg, M.D.
 Internal Medicine, Hematology,
 Oncology

Maurice Frankel, M.D.
 Surgery

Adrian Thieck Go, M.D.
 Internal Medicine, Gastroenterology

Aubrey Goldman, M.D.
 Internal Medicine

Raymond Henkin, M.D.
 Internal Medicine,
 Pulmonary Diseases

Lawrence Hoffman, M.D.
 Ophthalmology

Samuel Indenbaum, M.D.
 Internal Medicine, Rheumatology

Henry D. Kaine, M.D.
 Internal Medicine, Endocrinology

Arthur Kaselemas, M.D.
 Internal Medicine

Stuart Katz, M.D.
 Orthopedic Surgery

Murray Kling, M.D.
 Surgery

Kristina Kochanowska, M.D.
 Internal Medicine, Diabetes

Manus Krasman, M.D.
 Internal Medicine, Gastroenterology

Herbert Lanfor, DPM
 Podiatry

James Lesser, M.D.
 Internal Medicine, Rheumatology

Jack Litwin, M.D.
 Internal Medicine

Walter Livingston, M.D.
 Internal Medicine, Endocrinology

Edward Mainowski, M.D.
 Internal Medicine, Cardiology

Jolanta Mainowski, M.D.
 Dermatology

Jack Mandberg, M.D.
 Internal Medicine

John Mucasey, M.D.
 Internal Medicine

Lloyd Paul, M.D.
 Internal Medicine,
 Pulmonary Diseases

Sidney Pystowski, M.D.
 Internal Medicine, Allergy

Harvey Sabbata, D.O.
 Internal Medicine, Cardiology

Bruce Samarian, M.D.
 Internal Medicine

David Shepherd, M.D.
 Ophthalmology

Manuel Sklar, M.D.
 Internal Medicine, Gastroenterology

Richard Small, M.D.
 Radiology

Lisa Beth Speck, M.D.
 Internal Medicine

Sharon Tice, M.D.
 Pediatrics, Adolescent Medicine

Harold Wasserman, M.D.
 Internal Medicine

Raymond Weitzman, M.D.
 Internal Medicine, Rheumatology

Peter Winston, M.D.
 Radiology

David Young, M.D.
 Internal Medicine

Irving Young, M.D.
 Internal Medicine

Burton Zack, M.D.
 Head and Neck and General
 Surgery, Industrial Medicine

Ronald Zack, M.D.
 Obstetrics, Gynecology

Jeffery Zaks, M.D.
 Internal Medicine, Cardiology

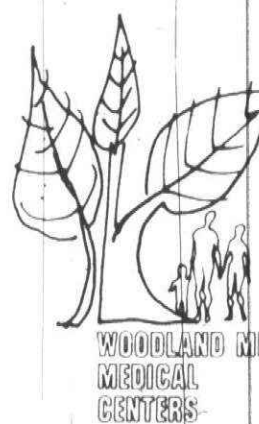

"Caring For The Entire Person
 ...The Entire Family."

Physicians Appointment Hours Are
 Monday through Friday 8 AM to 5 PM
 Saturday 8 AM to 4 PM

WALK-IN URGENT CARE (Unexpected Need)
 Monday through Saturday 8 AM to 10 PM
 Sunday 10 AM to 6 PM

Pediatrics Hours Are
 Monday through Friday 8 AM to 8 PM
 Saturday 8 AM to 4 PM

For Additional Information Please Call Our Patient Advisor

22341 West Eight Mile Road
 Detroit, Michigan 48219
 538-4700

41935 West Twelve Mile Road
 (Next to Twelve Oaks Mall)
 Novi, MI 48050
 348-8000 or

855-3222 (toll free most areas)

Little progress on county charter

By BOB WISLER

The Wayne County Charter Commission, elected in November to fashion a new county charter by June 15, has a long way to go if its public meeting held Tuesday is any indication.

Although the 27 charter commissioners have been meeting since Nov. 28, they have yet to make a decision as to the kind of county government that will be called for under a new charter.

The most-debated question Tuesday was whether the commissioners would open their public meetings with 1) a prayer, 2) the Pledge of Allegiance or 3) 30 seconds of silence.

THE ISSUE, postponed from previous meetings, sparked the most spirited debate of the day.

During 30 minutes of discussion about the wisdom of each of the alternatives and the parliamentary procedure that should have, or should not have, been followed, the commission voted to postpone consideration of the

alternatives indefinitely. The meetings will start with prayer, pledge or period of silence.

Tracy Salisbury, a commissioner from downriver communities, invoked four separate passages from the Bible in an effort to persuade fellow commissioners that the meetings should start with an invocation.

Ramon Tefelski Jr., who represents several western Wayne County communities, spoke on behalf of the Pledge of Allegiance, which, he said, includes the statement "one nation under God."

Commissioner Michael Einheuser of Detroit objected to Salisbury's statement that the charter commissioners should reflect the nation's Christian heritage. Einheuser said this did not take into account the religious beliefs of Jews and other non-Christians.

Several rulings by Chairman George Ward, a Detroit attorney, and the commission's parliamentarian failed to convince the entire commission that the matter could be decided by voice vote.

IN OTHER MATTERS the commission heard:

Wayne County Prosecutor William Cahalan speak in favor of an elected executive to head Wayne County.

Self-styled gadfly Bradford White criticize the commissioners for setting up a committee structure which includes eight subcommittees. White claimed that the charter commission has 51 sub-committee posts, 10 more than the number of sub-committee posts created by the "much criticized" county board of commissioners.

Charter Commissioner William Copeland — a former political power broker as a state legislator and now a commissioner from Wyandotte — urged out-county charter commissioners to get together to work for a big suburban vote for an elected county executive in the Nov. 4 election. Commissioners estimate this will be the date voters will be asked to approve a new county charter.

Copeland claimed that a Detroit faction would be utilizing the November mayoral election of Coleman Young to

influence voters to approve an appointed county manager over an elected executive.

Cahalan said he was convinced that an elected executive is absolutely necessary to improve Wayne County government. He said that unless the public approves such an executive, the fragmented Wayne County government will not be improved to the extent that conditions demand.

THE COMMISSIONERS have been holding two full meetings and eight subcommittee meetings every week since January.

Commissioners said most of the meetings have been spent looking at the way county government now operates.

They aren't expected to start making decisions on the new charter until some time in April.

Several said they were satisfied with the progress the commission has been making.



Motel to begin

Construction will begin soon on the new motel/parking structure which will start above the present Roundtable Club and extend over the Wiedman Parking Lot. Phase II will involve the arched pedestrian walkway connecting the new motel with the Meeting House porch across Main Street. Among those at groundbreaking ceremonies recently were (from left) Ralph and Mable Lorenz, and sons Scott and Randy Lorenz.

Jump rope for heart

West Middle School will be promoting physical fitness with a Jump Rope for Heart event on March 17.

The event is sponsored by the Michigan Association for Health, Physical Education and Recreation and by West Middle School to benefit the Michigan Heart Association.

Student participants will work in teams of six. One team member jumps rope for 2-3 minutes and passes the rope to the next team member.

Each team member will jump in order and must rest when not jumping. Students will be asked to acquire

sponsors before the event. A pledge will be based on each minute that the six-member team jumps.

As an example, if the team jumps the full three hours (180 minutes) and a pledge of two cents per minute is made, the sponsor would contribute \$3.60 to the heart fund.

The jumping will be 2-5 p.m. March 17 at the school.

Rick Wilson and Kathy Mineau are coordinators of the event and welcome anyone to come to the West gym and make a pledge or to cheer on the participants.

FRENCH
With Alliance Française de Detroit
at Bloomfield Hills Academy
10-class term begins Mar 25 - call off-ice for brochure

Everything you need is available at
PLYMOUTH TOWNE APARTMENTS
Enjoy healthy independence in this beautiful new complex.
One and two bedroom apartments for Senior Citizens including:
• Transportation
• Optional social activities
• Medical security
• Two meals
• Housekeeping services
• Linens
OPEN 9-5 DAILY
12-3 Sat. & Sun.
Now Taking Reservations
Call or visit
The Plymouth TOWNE APARTMENTS
107 Haggerty Road
Plymouth, MI. 48170
(313) 459-3890

CLIP AND SAVE
Pride Plumbing Supply
Do-It-Yourself Plumbing Parts
2829 Plymouth Rd. Between Beech & Inkster Rd. 425-8510
Hours: 9-6 Mon.-Sat.

SAVE Heater Sale SAVE

40 Gal. RHEEM HEATER
Reg. \$169.90
Now Only \$139.90

- Aluminum Gas Burner
- Fiberglass Insulation
- Glass Lining
- Low Input Pilot
- Maximum Efficiency & Economy

RHEEM GLASS FURY
ECONOMY AND PERFORMANCE

SAVE EXPIRES 4-15-81 SAVE

I-S-E BADGER 1/2 HP DISPOSALS
SAVE! 25%
Reg. \$53.95
NOW \$39.95
EXPIRES 4-15-81

GRADE B WHITE TOILET
\$49.95
WHILE SUPPLIES LAST

Super Savings on Top Quality Paint from Town 'n' Country Hardware

LOOKS LIKE A FLAT PAINT
WASHES LIKE ENAMEL!

E-Z KARE
LATEX FLAT ENAMEL
Reg. \$17.98
SALE \$12.98

Save **\$5.00**

High-hiding, fully washable flat white latex. For all type walls.
Reg. \$10.98
SALE \$7.98

Resists grease, soil and washing. Easy to apply. White only.
Reg. \$12.98
SALE \$9.95

Also Your Headquarters for All Painting Accessories.

TOWN 'N' COUNTRY Hardware & Fireplace
27740 FORD ROAD • GA 2-2750
3 1/2 BLOCKS W. OF INKSTER ROAD OPEN DAILY 9-8; SAT. 9-6; Closed Sunday

REMVEST
Securities, Inc.
Call 425-9000

Tax Deferred
16.5% annual yield
A \$10,000 deposit earns **\$1,780.70** per year!

- \$10,000 minimum not required
- Diversification
- Quality Portfolio

CALL, WRITE or COME IN.

Metro North: Remvest North Building
22821 Orchard Lake Road
Farmington, MI 48024
313/476-6670
State Headquarters

Metro West: Remvest Building
33636 Five Mile Road
Livonia, MI 48154
313/425-9000

Convenient local offices also in:
Flint 313/733-6780 Kalamazoo: 616/372-5940
Grand Rapids: 616/942-1980 Midland: 517/636-7020
Saginaw: 517/792-9575

*May be tax deferred within the structure of your Keogh, Pension Plan or Individual Retirement Account, either new or existing. ATTENTION: REGENT RETIREES with lump sum pension money, roll over into an Individual Retirement Account to further defer taxes.

REMVEST
Yes, I'm interested in increasing my investment potential

NAME _____
ADDRESS _____
CITY _____ STATE _____ ZIP _____
PHONE AREA _____

Englander's Furniture Warehouse
CLEARANCE CENTER
Everything 1/2 off!
(And More!)
ONE DAY SALE
SATURDAY, MARCH 14
10 a.m. - 5 p.m.

During the 7 Hour Sale at Englander's Clearance Center, you'll find the best names in furniture, for 1/2 off and more!
Choose from an incredible selection of merchandise, all from our regular stores; One-of-a-kinds, floor samples, cancellations, slightly damaged and discontinued items.
All items sold as shown. No layaways. All sales final. All items subject to prior sale. 1/2 deposit is required. **All items must be delivered or picked up by March 28th.** Take with to save delivery charges.

Sofas • Bedroom & Dining Room Groups
• Sleepers • Modular Groups • Occasional and Imported Tables • Wall Units
• Bookcases • Lamps • And more...
Both traditional and contemporary.

Campaign style youth bedroom group in pecan finish.
From \$89 per piece

Henredon Scene I Bedroom. Double dresser, storage headboard, island bed and 2 nite stands.
Reg. \$3,219
Sale \$1,599 (2 to sell)

6 piece light oak contemporary dining group. (Table, china, 4 chairs.) Additional chairs available. Reg. \$2,399
Sale \$1,099

Sleepers—Contemporary and Traditional. Full or Queen size. Reg. \$810-\$910
Sale \$399-\$499

Wall systems, Etageres, Bookcases.
From \$99 per piece

Ficks Reed Rattan. 1981 Factory Showroom samples
60% OFF

Occasional tables from Drexel, Thomasville, Henredon, Hekman and Weiman.
50%-70% OFF

Sofas and loveseats.
Reg. \$650-\$1,450
Sale \$249-\$699

Also available: sectionals, pit groups and chairs at 1/2 off and more. Thayer Coggin, Flair, Drexel, Henredon, Heritage, Century, Selig.

BREVITIES



BREVITIES DEADLINE

Items for Brevities should be submitted by noon Monday for the Thursday issue and by noon Thursday for the Monday issue. Mail or bring to the Observer news office at 461 S. Main, Plymouth. Forms are available upon request.

PARENT COFFEE

March 12 — A parent coffee will be held at 9:30 a.m. in the conference room at Plymouth Canton High School. Parents of all high school students may attend.

SKI TRIP

March 13-15 — The Canton Parks and Recreation Department is planning a ski weekend at Schuss Mountain for adults. The cost is \$80 per person for two-person rooms and \$72 per person for four-person rooms. A \$25 deposit is required at the time of registration. For further information and reservations, call the recreation department at 397-1000 between 8:30 a.m. and 5 p.m.

ESSAY CONTEST

March 15 — Plymouth Community Civitan Club is sponsoring the 1981 Civitan Citizenship Essay contest. The to-

pic this year is "Forecasting the '80s: The Role of the Involved Citizen." Competition is open to all juniors and seniors at Centennial Educational Park. First-, second- and third-place prizes will be worth \$50, \$30 and \$20, respectively. Students may apply by contacting English teachers at the CEP. Deadline for entries is March 15.

SHRINE CIRCUS

March 25 — A field trip to the Shrine Circus for Track A students will leave Canton Township administration building on Canton Center Road at 12:30 p.m., returning at 4:45 p.m. Price is \$2 per person.

The trip will be repeated April 1 for students on Track B.

For registration, call or write the Canton Township Recreation Department, 1150 S. Canton Center Road, Canton 48188, or phone 397-1000 between 8:30 a.m. and 5 p.m.

RECIPE BOOK

March 31 — The Canton Jayettes are putting together a recipe book to be sold with the proceeds going to benefit the Canton Library. The group seeks community support. Recipes may be sent, along with your name and telephone number, to Connie Kish, 2698 Brookfield, Canton 48188, telephone: 397-1161. Deadline is March 31. Space

limitations require a limit on the number of recipes which may be printed.

LAMAZE CLASS

Couples anticipating the birth of a baby in the next five or six months should enroll now for classes in the Lamaze Method of Prepared Childbirth offered in the Plymouth Cultural Center, 525 Farmer, Plymouth. The classes prepare prospective parents physically and emotionally for the birth, and are taught by a registered nurse. Registration is available by calling 425-3750 or 827-8750.

JOB TRAINING

Michigan Employment Program (MEP), offered by Growth Works Inc. in Plymouth, is now inviting interested employers to participate in on-the-job

training with optional subsidy. For further information contact Judy Cavell at 455-4094.

SENIOR TRIPS

The Plymouth Recreation Department is sponsoring two trips for senior citizens this spring in cooperation with the Travel Company. An April 2, a trip will be taken to the Paw Paw Winery and Upjohn Pharmacolmaceutical Co. A two-day trip to the Holland Tulip Festival is scheduled for May 14-15. For further information, call Traci Johnson at 455-6620.

PROPERTY TAX HELP

Canton Senior citizens club has volunteered its help to Canton senior citizens and disabled persons with their property tax rebate and home heating

credit forms from 10 a.m. to 2 p.m. on Tuesdays when Judy Boys and Fred Umbrasas will be at the Canton Recreation Center and from 10 a.m. to 2 p.m. Wednesdays at the same location with Maude Truesdell and Milt Roettger assisting. Available Thursdays from 10 a.m. to 2 p.m. will be Isabel Hale and Harold Beattie at the rec center. For an appointment, call 397-1000, ex. 278.

PLYMOUTH ENERGY PROGRAM

City of Plymouth residents may see an infrared picture of their home by stopping by the city manager's office in city hall from 10 a.m. to 5:30 p.m. Wednesdays or from 10 a.m. to 1 p.m. Saturdays. A trained interpreter will explain what the picture means and offer energy tips.

AFTER-SCHOOL CAMP

The Plymouth Community Family YMCA will sponsor an after-school pro-

gram for kids from 3:45-5:45 p.m. every school day at Starkweather School. Bus transportation will be provided to Starkweather from all schools in Plymouth and Plymouth Township. For additional information, call the YMCA at 453-2904.

SENIOR ADULT FITNESS

A free senior adult fitness club is held from 2-3 p.m. each Friday in First Methodist Church on North Territorial Road in Plymouth under the sponsorship of the Plymouth Family YMCA. Instructor is Ann Fowler. For information, call the Y at 453-2904.

HANDYMEN

Retired handymen will perform odd repair jobs for a minimal cost through the Plymouth Community Council on Aging. For further information, call 455-4907.

(Continued on Page 11A)

Lecture series to begin today

The first event in the Spring '81 Lecture Series sponsored by the Plymouth Centennial Educational Park (CEP) National Honor Society will feature a debate on nuclear power.

The debate begins at 7:30 p.m. in the Plymouth Canton High Little Theatre.

The anti-nuclear position will be taken by Steve Freedkin, a former director of the Public Interest Research Group in Michigan (PIRGIM) and an energy consultant for U.S. Sen. Donald Riegle, D-Mich.

Taking the pro-nuclear position will be a representative from the Bechtel Power Corp. of Ann Arbor, a firm involved in the development of nuclear energy.

All series begin at 7:30 p.m. Thurs-

days in the Little Theatre of Canton High, on Canton Center Road just south of Joy.

On April 2, there will be a lecture on "Political Conditions in El Salvador and Other Latin American Nations" by Kenneth P. Langton, professor of political science at the University of Michigan.

On May 7, there will be a musical recital and lecture entitled "New Trends in Sax" by Mark Thrasher, a recent graduate of Plymouth Salem High now attending U-M on a music scholarship.

The series will end on June 4 with a reading and lecture entitled "Some Thoughts from Life" by Jim Burnstein, a freelance writer for newspapers and television shows.

Send a Belly Gram or Sheik A Gram
A Dancing Special Delivery For All Occasions

Birthdays
Anniversaries, Weddings
Check a friend in the hospital,
or for your
St. Patrick's Day Party.

Belly Gram, Inc.
Ann Arbor
Detroit
967-4094
Lansing
(517) 349-2867

ENERGY COSTS CONSERVE IT...

Bring the Family to the HOME & GARDEN BUILDER'S SHOW COBO HALL MARCH 14-22

See Our Energy Saving Ideas

Call Us Today 581-1400

5405 Oakman Blvd., Dearborn (Between Ford and Michigan)

DOLLAR DAYS ARE HERE!

WE'RE NOT A DRUGSTORE, BUT WE CAN HAVE DOLLAR DAYS TOO, SO DON'T MISS OUT ON THESE SUPER SPECIALS!

- COMPLETE LUBRICATION**
We'll grease your complete G.M. car or light truck.
\$2.00
- TIRE ROTATION**
Rotation of "4" tires on any model car or light truck.
\$4.00
- FAN BELTS**
We'll inspect and adjust ALL of your engine fan belts. This special is also good for any model car or light truck.
\$2.00

OFFER GOOD 'TIL 3-20-81
Coupon must be presented at the time of write up.

Keep that great GM feeling with genuine GM parts.

GM QUALITY SERVICE PARTS
GENERAL MOTORS PARTS DIVISION

GENE MEROLLIS CHEVROLET

31850 FORD RD. Garden City 427-6200

The Highest Legal Rate on 182 Day Savings Michigan Money Market Certificates

Earn \$691.45 in just 182 days on a deposit of \$10,000.

13.677%
Annual Interest Rate*

14.350%
Effective Annual Yield*

Effective Thursday, March 12, 1981 thru Wednesday, March 18, 1981.

A minimum \$10,000 deposit is required. Federal regulations require a substantial interest penalty for early withdrawal and prohibit the compounding of interest on these certificates.
*The effective annual yield is subject to change at renewal and assumes that the interest rate remains unchanged and that both the interest and principle are reinvested. Earnings and effective annual yield shown apply to all Michigan National Corporation Banks in Southeast Michigan.

Michigan National Corporation Banks

MEMBERS FDIC

\$5.7 Billion of Assets.
Deposits Insured to \$100,000 by Federal Deposit Insurance Corporation

14K GOLD ESTATE JEWELRY SALE

Buy 14K gold jewelry at a fraction of retail cost!

All 14K Gold rings, chains, bracelets, charms, pins, brooches and rings. Antique settings, some with precious stones.

Fashion Jewelry Values to \$20

NOW ONLY \$1 PER GRAM

BUYING DIAMONDS & FUR COATS

Mink Jackets, Stoles, Full Length Coats

ALSO BUYING LIONEL TRAINS

WANTED Your Gold and Silver Items

WE STILL PAY MORE!

NO APPOINTMENT NECESSARY! CHECK OUR PRICES FIRST! Please bring your items to the nearest location. Please count and separate your coins. Also buying Hummells, Ivory & Scrim Shaw

PAYING CASH FOR
STERLING SILVER
Sterling Flatware Sterling Silver & Other Sterling Items

We buy anything marked sterling, .925 or .999-spoons, forks, knives, plates, candlesticks, trophies, trays, frames, tea sets, etc.

U.S. SILVER COINS

SILVER DOLLARS WANTED
MINTED BEFORE 1935
ALSO BUYING BU SILVER DOLLAR ROLLS MINTED BEFORE 1921
ALSO BUYING HALF DOLLARS 1965
TOP DOLLAR PAID FOR ALL RARE COINS
SMALL & LARGE QUANTITIES WANTED
NO APPOINTMENT NECESSARY

BUYING

- Rings
- Old Pocket Watches
- Gold Watches
- Sterling Silver
- Scrap Gold
- Class Rings
- Dental Gold
- Foreign Gold
- Canadian Coins
- Gold Rings
- Any Old U.S. Coins
- Old Music Boxes
- Industrial Silver
- Gold Teeth
- Swords
- Diamonds
- Old Baseball Card
- Franklin Mint
- Silver Bars
- Proof Sets

LIVONIA AREA
COIN INVESTMENTS OF LIVONIA
10988 Middlebelt Livonia, Michigan
525-4100
(next to Detroit Fed. Svgs.)

BIRMINGHAM AREA
MIDWEST COIN INVESTMENTS
725 S. Adams, S. of Maple Rd. Birmingham, Michigan (on the South Adams Square Mall)
642-5081
25 years same location

HOURS: OPEN MONDAY THRU SATURDAY 10 A.M. to 5:30

Scales Certified by Weights and Measures SUBJECT TO MARKET

BREVITIES

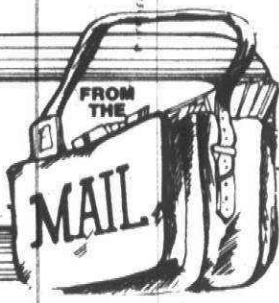

(Continued from Page 10A)

Items for Brevities should be submitted by noon Monday for the Thursday edition and by noon Thursday for the Monday edition. Mail or bring to the Observer news office at 461 S. Main, Plymouth. Forms are available upon request.

• AMERICAN RED CROSS

The Red Cross Northwest Wayne County satellite office and regional blood donor center in Livonia has moved to a new location in the Belle Creek Office Plaza, 29691 W. Six Mile Road. The former site was 15457 Middlebelt. The phone number will remain the same: 422-2787.

• GROUP HOME INFORMATION

March 12 — A meeting will be held at 7:30 p.m. in the Fellowship Hall of the First United Methodist Church, 45201 N. Territorial (west of Sheldon). The purpose of the meeting is to provide information to Plymouth residents about a proposed group home for mentally retarded adults at 741 Beech Court. Staff from the Northville Residential Training Center will give information and answer questions.

• EAGLES MEETING

March 15 — A planning meeting will be held at 2 p.m. at the Cypress Gardens Restaurant, in the Harvard Square shopping center at Ford and Sheldon roads. Meeting will be repeated March 22 at the same location. The Fraternal Order of Eagles is a service club. The organization also plans to organize a women's auxiliary group. For information, call Les Cooper at 728-0022.

• SAFE BOATING CLASS

March 17 — The Plymouth-Canton Community Education Department of the school district is offering an eight-hour course on safe boating. The class is designed for youth 12-16 years old, and will be taught by the Wayne County Sheriff's Department marine division. Registration deadline is March 17, and interested persons should call the community ed department at 459-1180. Classes will be held 4-6 p.m. on March 17, 19 and 24 in Room 120 of Plymouth-Canton High School.

• LAKEPOINTE HOMEOWNERS

March 25 — Property taxes will be the subject of a meeting at 8 p.m. in Farrand School on Greenbriar Road.

Speaking to the Lake Pointe homeowners group will be state Sen. Robert Geake, Wayne County Commissioner William Joyner and Plymouth Township Supervisor Maurice Breen.

• AMERICAN LEGION

April 5 — The American Legion Wayne Post 111 will hold a meeting at 2 p.m. in the post hall at 4422 S. Wayne Road, Wayne.

• VOLLEYBALL LEAGUE

Registration is taking place for coed teams in a volleyball league through the Plymouth-Canton Community Schools. Practice sessions are April 8 and 15, with games beginning April 20. The league will be held Wednesdays for

10 weeks. Fee is \$100 per team. For information, call 459-1180.

• USED BOOK SALE

April 10-12 — A used book sale will

take place at Kings Row shopping center at Lilley and Warren. The Friends of the Canton Public Library is looking for books, comics, puzzles, games, re-

cords and toys. Items should be brought to the library, 1150 S. Canton Center Road. All proceeds of the sale will benefit the library.

Breathing tips nothing to sneeze at

Practice pursed-lip breathing. Learn how to cough. Exercise your chest muscles.

These are just a few of hundreds of suggestions to "Help Yourself to Better Breathing," a new booklet published by the American Lung Association especially for persons with emphysema and chronic bronchitis.

Chock-full of excellent "how-to-hints,

there are first-person stories about how people have learned to cope with breathlessness and specific directions on how to clear breathing passages of mucus.

Exercises for postural drainage and building stamina are illustrated.

Another section identifies troublemakers, such as air pollution, extremes of weather, infections, and

smoking, and how to avoid them.

Breathing aids, such as nebulizers, respirators, oxygen, humidifiers and vaporizers are described. There is even a section on eating to feel better.

"Help Yourself to Better Breathing" is available from the American Lung Association of Southeastern Michigan (ALASEM). For a free copy of the booklet, call 961-1697.

MICHIGAN'S LARGEST PENNSYLVANIA HOUSE DEALER

Since 1937

A Beautiful Store with Beautiful Furniture
America's most distinguished traditional furniture

Colonial House
20292 Middlebelt Rd. (South of Eight Mile)
Livonia
Open Mon., Thurs. & Fri. Til 9 P.M. 474-6900

PRICES SLASHED! HONESTLY...

Bathroom
CERAMIC TILE
\$249⁹⁵
LABOR & MATERIAL

Choice of many Colors. Completely installed in Tub area (up to 50 sq. ft.)

AJAX FLOOR COVERING
32639 FORD ROAD
1/2 BLK E. OF VENVOY
427-6620
FREE ESTIMATES
EXPERT INSTALLATION

CASH IN ON SAFETY

Exchange your old prescriptions for chances to win **\$100 or \$50** at each hospital

Bring Outdated Prescriptions to:

- Annapolis Hospital • St. Mary Hospital
- Garden City Osteopathic Hospital
- Wayne County General Hospital • Metropolitan Hospital-West

March 17-21
(12 Noon-7 P.M.)

National POISON PREVENTION WEEK

KITCHEN REMODELING

CUSTOM PLANNING
EXPERT WORKMANSHIP

A Wide Variety of Styles & Colors in Wood or Formica - Appliances. Complete Installation or Do-It-Yourself

FREE ESTIMATES
525-0050
KEPLEYS
KITCHEN & BATH
27854 Ford Rd.
Garden City

FREE
This Genuine Harvard Tennis Table
Tournament Set (retail value \$129.95) with the purchase of a **PENNVILLE ALL-WOOD CUSTOM KITCHEN** during February and March

OUT-OF-SIGHT SAVINGS ON EYEWEAR AND CONTACT LENSES

\$20⁰⁰ OFF Bausch & Lomb or American Optical Soft Contact Lenses Reg. Price \$69

New soft lenses that were \$69.00 are just \$49.00 with presentation of this coupon at time of purchase. Professional and fitting fees not included. Prior discounts do not apply. Offer expires March 31, 1981. (One coupon per purchase.)

PEARLE vision center
A SEARLE COMPANY

\$10⁰⁰ OFF Complete Pair of Prescription Eyeglasses.

Save \$10.00 on a complete pair of prescription glasses. Choose from our large selection of fashion, classic and children's frames. Present this coupon at time of purchase to claim your discount. Prior discounts do not apply. Offer expires March 31, 1981. (One coupon per purchase.)

PEARLE vision center
A SEARLE COMPANY

\$3⁰⁰ OFF Tinting of Halfweights® Brand Lenses

Bring in this coupon at time of order and get \$3.00 off the tinting of Halfweights® brand lenses, when purchased. Prior discounts do not apply. Offer expires March 31, 1981.

PEARLE vision center
A SEARLE COMPANY

GROSSE POINTE WOODS—21207 Mack, Tel. 886-1066 • SOUTHGATE—Southgate Shopping Center, 13615 Eureka Rd., Tel. 283-6800 • LIVONIA—20365 Middlebelt Rd., Tel. 478-0234 • 34901 Plymouth Rd., Tel. 425-2400 • ALLEN PARK—14595 Southfield Rd., Tel. 382-5100 • GARDEN CITY—29316 Ford Rd., Tel. 261-6868 • BELLEVILLE—Lakewood Shopping Center, 2085 Rawsonville Rd., Tel. 485-3580 • CANTON—44750 Ford Rd., Tel. 455-3190 • DETROIT—9350 Telegraph Rd., Tel. 533-4800 • 18351 Plymouth Rd., Tel. 273-1102 • 19841 W. 8 Mile Rd., Tel. 531-7460 • TAYLOR—11050 Telegraph Rd., Tel. 946-9572 • DEARBORN—23050 Michigan Ave., Tel. 274-8815 •

For other locations call toll-free 800-331-1000.

© 1981 Searle Optical Inc., Dallas, Texas USA

Karastan always puts a high price on quality. Even now, when there's a sale price on it.

If you've always thought Karastan was a bit out of reach, get in touch with your nearest participating Karastan dealer.

For a limited time only, he or she can show you specially selected Karastan rug and carpet styles on sale at savings of up to 25%.

So what better time to acquaint yourself with Karastan's famous quality through a wide range of carpet textures, styles, and our extraordinary palette of colors.

Or, perhaps, the mystery of our selected Oriental design wool rugs could solve your decorating problems.

Despite the savings, if you still think of Karastan as too luxurious, consider the results of a recent torture test Karastan arranged.

We put one of our Prestige Velour car-

pets down in New York's Grand Central Station and let 180,000 merciless feet beat a path across it. After we picked it up, all we did was give it a stringent cleaning.

You can see for yourself in the photograph above that the fragile beauty of this particular Karastan is anything but fragile.

Karastan has long been considered extraordinary carpet. But now, during the sale, it will also be offered at extraordinary savings.

This is brand new Karastan. This is the same carpet after what amounts to 3 years of use. See the difference in wear? We can't either.

Karastan

Karastan Rug Mills, a Division of Fieldcrest Mills, Inc.



Winners in the Optimist Club oratorical contest were: (from left) Tresha Hillfing, Ingrid Erickson and Julie Sparling.

Optimists honor top student talkers

Oratorical contest winners in the boys and girls competitions have been announced by the Plymouth Optimist Club.

The competitions were held recently during the weekly dinner meetings of the Optimist Club in the Mayflower Hotel.

Students competing were asked to give a four-five minute talk on the topic "A Commitment to Share."

There were 10 female contestants from West Middle School, Pioneer Middle School, Central Middle School, Our Lady of Good Counsel Catholic School and Plymouth Christian Academy.

The winners were: first place, Julie Sparling of Amherst Ct. Plymouth, West Middle School; second place, Tresha Hillfing of Portsmouth Crossing, Plymouth, West Middle; and runner-up, Ingrid Erickson, Mapletree, Plymouth, Pioneer Middle School.

They will advance to competition on April 11 at the Orchard Ridge campus

of Oakland Community College in Farmington Hills where they will compete with speakers from the metropolitan Detroit area.

The age limit for the contest is no older than 15 by Dec. 31.

There were five male contestants from Pioneer, West, Central middle schools and Plymouth Christian Academy.

The first-place winner was Larry O'Connor of Robinwood, a student at Central Middle School.

Second-place winner was Keven Fielman of Robin Ct., a West Middle student, and the runner-up was Doug Soho of Crestwood, Plymouth, a student at Central Middle.

These winners will advance to regional competition at Orchard Ridge on April 4.

Judges for the girls contest were: 35th District Judge Dunbar Davis, attorney Thomas Healy and John Sullivan, all of Plymouth.

Let's rescind the reprimand

Editor:

An article concerning the reprimands issued to Bob Smith, principal of West Middle School, was given front-page coverage by your newspaper. A short statement correcting your original article was buried in your obituary section. A letter from Smith with additional corrections was placed on a back page.

I strongly object to the minimal coverage given to the other side of the story. I was present, as were many other residents, at both meetings where Smith made the comments that Dr. John Telford considered not only objectionable but reprimandable.

Bob Smith spoke forcefully and straight-forwardly about the advantages that he believed inherent to the West Plan. He also stated clearly his disagreement with the board/central administration grade re-alignment plan. At no time did I hear him make a comment that I would consider offensive in any way.

Because only Smith's reprimand has been discussed publicly, it is impossible to know what reprimands were issued to the other administrators present at those meetings. But I do wish to state clearly that if by the district's standards, Mr. Smith deserved reprimanding, then several other participants were equally deserving.

My personal opinion is that no reprimands should have been issued. How can this community expect to have free and open discussion or debate when employees who hold minority views have to watch and measure every comment in order to avoid "nitpicking" reprimands?

I urge the school board to take immediate action to rescind the reprimands given Smith by Dr. Telford in order to reassure the community that staff input of the freest sort is welcomed and encouraged.

I urge the Observer newspaper, in the interest of fair play and objective reporting, to continue to follow this story and to give Bob Smith an equal chance to vindicate himself and clear his record with the public by placing additional information and articles on the front page of your paper.

LYNN S. HOEHN
Plymouth

This parent did research

Editor:

I feel compelled to respond to Jackie LaChapelle's letter of March 2. She questions why Canton parents bought "in an area that already was overcrowded."

Prior to our move here three years ago, we did extensive research into what educational facilities were available for our children. We were concerned about classroom size, availability of special education, and general teaching quality. Plymouth-Canton was ranked among the top three school systems in the metro area.

We were not told that, by the time our house was finished, the closest school would be so crowded that only our kindergartener could attend there and that our third-grader would be bussed several miles away.

We were not told that, by the time our oldest child was in sixth grade, we would be contending with both ESY and TSY schedules. We were not told that our children would be shuffled from one school to another every two

years. What we were told was that the area had good schools, shopping and was a great place to live.

Yes, we did our "homework," Mrs. LaChapelle, and I'm sure many other parents did also.

No, ESY is not an ideal situation. I would like nothing better than to escape it. Since that is impossible with the current housing market, I intend to make the situation as tolerable as possible for my family.

Instead of haggling over an issue we've already lost, why don't we all start fighting collectively for more quality teachers and educational materials? Our energies would be much better spent, and that is definitely an area where improvement is greatly needed.

KARIN DAINES,
Canton

from our readers

LETTERS THAT DO NOT APPEAR IN THIS COLUMN ARE CONSIDERED UNAPPROVED BY THE PINE CASHWAY LUMBER COMPANY.

IT'S THE SAVING OF THE GREEN



BUCK-A-BUNDLE REFUND ON EACH PACKAGE

CertainTeed OF 6" UNFACED INSULATION

UNFACED	50. FT.	ROLL	ACTUAL COST
6x15 (49 S.F.)	R-19 22c	\$10.78*	\$9.78
6x23 (75 S.F.)	R-19 22c	\$16.50*	\$15.50
DRAFT-FACED	50. FT.	ROLL	ACTUAL COST
3 1/2 x 15 (88 S.F.)	R-11 14c	\$12.32*	
3 1/2 x 23 (135 S.F.)	R-11 14c	\$18.90*	
6x15 (49 S.F.)	R-19 23c	\$11.27*	
6x23 (75 S.F.)	R-19 23c	\$17.25*	

LESS MANUF. REBATE

THE HIGHER THE R-VALUE, THE GREATER THE INSULATING POWER



DRYWALL

4x8-3/8" — \$304*
4x8-1/2" — \$309*

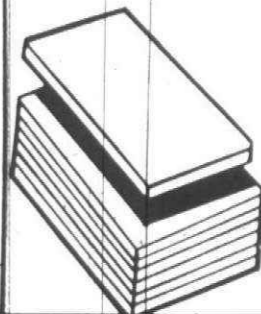

JOINT COMPOUND
5-GAL. \$795*
PRIMER \$1085*
2-GAL.

GUTTERS

WHITE ALUMINUM
5" GUTTERS
10' \$7.60

DOWNSPOUTS
10' \$5.75

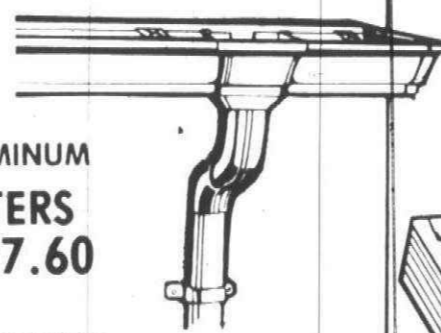

CDX SHEATHING PLYWOOD

4x8-1/2" \$849*

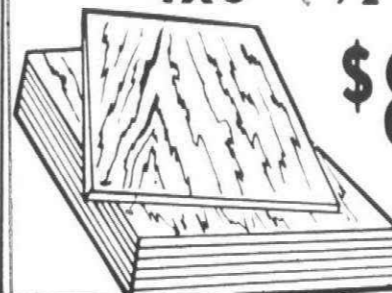

ROOF CEMENT

LIQUID ROOF COATING
GAL. \$395
5-GAL. \$1375
PLASTIC ROOF CEMENT
GAL. \$399
5-GAL. \$1400



STUDS

CONSTRUCTION GRADE

2x4-7' — 87¢*

2x4-8' — \$1.19*

ECONOMY GRADE

2x4-7' — 59¢*

2x4-8' — 79¢*

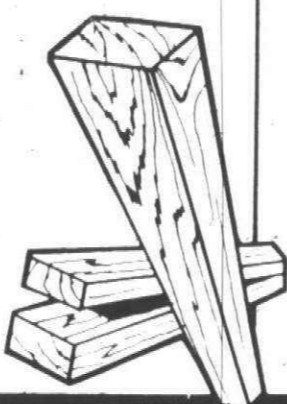

CEILINGING BY



2'x4' SUSPENDED PANELS

ROYAL OAK \$5.14 each

\$77.10 10'x12' ROOM (PANELS ONLY)

GRENOBLE

\$2.09 each

\$31.35 10'x12' ROOM (PANELS ONLY)

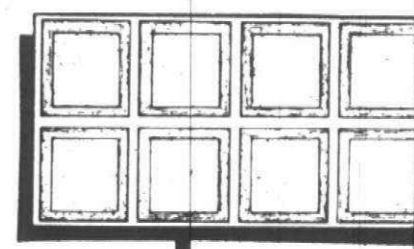

WHITE WOODS STANDARD GRADE

REG.	SALE
1x2 — 11' LIN.	10' LIN.
1x3 — 16' LIN.	15' LIN.
1x4 — 19' LIN.	17' LIN.
1x6 — 26' LIN.	23' LIN.
1x8 — 33' LIN.	29' LIN.
1x10 — 41' LIN.	39' LIN.
1x12 — 68' LIN.	59' LIN.

PLYWOOD

EXTERIOR GRADE GOOD ONE SIDE — 4'x8'

1/4" — \$10.29
3/8" — \$12.79
1/2" — \$15.25
5/8" — \$18.89
3/4" — \$21.45

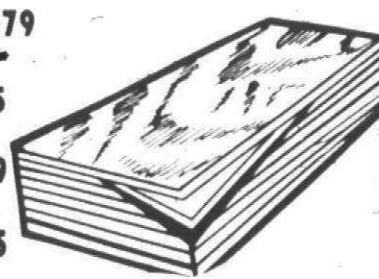

LUMBER CONSTRUCTION GRADE

	8'	10'	12'	14'	16'	18'	20'
2x4	1.19	1.79	2.39	2.75	3.59	3.99	4.59
2x6	2.59	2.79	3.95	4.39	4.99	5.89	6.89
2x8	3.14	3.84	5.61	5.95	7.10	7.62	9.54
2x10	3.76	4.69	7.43	9.11	9.56	10.12	11.70
2x12	6.99	8.75	10.65	11.85	14.39	16.79	18.95

PINE CASHWAY LUMBER

Our low prices help you make it.

BRIGHTON	525 Main St.	227-1831
DETROIT	5311 E. Nevada	368-1800
FENTON	14375 Torrey Rd.	629-3300
LINCOLN PARK	3255 Fort St.	386-5177
MT. CLEMENS	5 S. Groesbeck	469-2300
REDFORD	12222 Inkster Rd.	937-9111
SOUTHFIELD	22800 W. 8 Mile	353-2570
SOUTH LYON	20801 Pontiac Trail	437-4161
UTICA	48075 Van Dyke	739-7463
WATERFORD	7374 Highland Rd.	666-2450
YPSILANTI	629 N. Huron	481-1500

Some items may not be available at all locations. All items Cash & Carry - Sale items marked with *

OPEN: Mon. thru Thurs. 8 a.m. - 5 p.m. Friday 8 a.m. - 6 p.m. Saturday 8 a.m. - 4 p.m. Sunday 10 a.m. - 3 p.m.

PRICES GOOD MARCH 11-17

HYPNOSIS WORKS!

"I lost weight and have kept it off for over a year now. My attitude has changed and I feel terrific! Hypnosis made it possible."

Hypnosis Eliminates

- Weight
- Tension
- Smoking
- Habits & Fears

Hypnosis also improves study habits, personal problems and sports.

Call Now 471-0380

New Development Hypnotherapy Center

LIVONIA PAVILLION EAST
29200 VASSAR • SUITE 413 • LIVONIA



Juanita Dibattista

STOCK YOUR FREEZER NOW! Pasties Sale

BUY DIRECT FROM FACTORY

4 for \$1

Sealtest HOMO MILK \$1.77

Low Fat... 1.59 gal.

Frozen Food Center

5252 OAKMAN BLVD. DEARBORN - 582-2028 MON.-FRI. 8-6 SAT. 9-4
34805 FORD RD. WESTLAND - 721-3660 MON.-SAT. 10-7

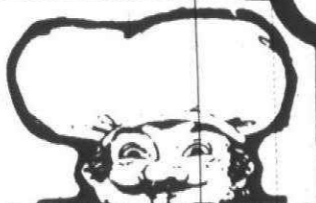

Hot Burritos	4 1/2 oz.	35¢
Beef & Bean Burritos	4 1/2 oz.	35¢
Hot Beef & Bean Burritos	10 oz.	65¢
Chef Pierre Pre-Cooked APPLE PIE	24 oz.	95¢

Prices good thru March 4

from our readers

Is the board representative?

Editor: We have arrived at a point that is both unsettling and downright dangerous. To illustrate, I'll use two points:

1. Dr. John Telford is quoted in reference to West Principal Bob Smith, his position (the P/C schools) is as a line officer. He provides input at the proper time, but the supervisor and the board make policy. It's a philosophical argument. He perceives himself as a policy maker, when he is a policy implementer.

2. At the Feb. 26 PCSC meeting, Tom Yack made an admittedly biased presentation on the negative effects of split sessions at the CEP. His rationale for not studying split sessions is that there are too many unknowns.

Looking at point one, certain words come to mind:

a. Democracy - From the Greek words "people plus to be strong to rule." Government by the people; Government in which the supreme power is retained by the people and exercised by representation as in a republic.

b. Repress - to check; curb, press or crush back down or out; quell, suppress; subdue.

Is the board of education representative when they refuse consideration of new ideas? The board of education is the ultimate policy maker, and I believe that if we get down to brass tacks, Mr. Smith is a policy implementer — right along with Dr. Telford, Dr. Homes, Shirley Spaniel and Dr. John Hoben who are hired by the board of education. Are we to believe that as concerned parents, teachers and building administrators we are denied the right to express our concerns openly and forthrightly? And who decides what time is proper and what remarks are appropriate?

Regarding point two, Mr. Yack has displayed the attitude which pervades most of the board — put on the blinders and shove ESY down the throats of a community that may no longer be able to afford it, and by all means, don't study any alternatives.

Dr. Hoben has suggested forming a 12x12x12 committee, i.e.: 12 committees studying 12 district problems for

12 weeks. I ask where was this when we needed it last year? The board has had a year to study ESY vs. split sessions vs. extended day. There may be other possibilities to be explored, who knows?

We are not the first district to be faced with overcrowding, and I doubt that ESY has been found to be the only or the best solution. Several districts have chosen split sessions as an alternative to overcrowding — if there are unknowns, let's find out what their answers are.

So board of education, where are your facts, figures and comparative studies? I'm getting a sickening feeling that the changes will be made, two more schools on ESY, a total of \$800,000 (or more) per year in operating expense alone for eight ESY schools, questionable curriculum changes, budget cuts and after a disastrous, disrupted, topsy-turvy '81-82. School year the beneficent board will offer the citizens the chance of a lifetime — nine bond issues. And we'll bite like starved dogs.

It is becoming more evident to me that there are people in positions of power who are so impressed with the judgment of a few, that they willingly relinquish their own power. At the same time, there are those who are so impressed with their own self-appointed power that they intimidate or deny the rights of others.

Have we gotten to the point where, when told to jump, we ask only "How High?" or do we have the courage to say, "No — you jump, in the lake!"

KATHLEEN B. ALLISON, Plymouth

Firefighters are praised

This is an open letter to Roy Hall, Plymouth fire chief.

Dear Chief Hall: Although I have repeatedly heard many sincere compliments on the efficiency and the sympathetic attitude of our rescue squad, I had not, until today,

been a witness to their truly outstanding service.

On Tuesday afternoon, Garnet Hawes, one of our residents, suffered a heart attack and rescue was summoned. From the first moment of their prompt arrival until our resident was delivered into the care of St. Mary Hospital personnel, the two firemen were untiring in their efforts to save Mr. Hawes. Unfortunately, this was not to be but the firemen spared no efforts in their vigorous attempt to preserve his life.

I feel that we all owe a tremendous debt to our fire department, both for past services and more importantly for the knowledge and assurance that competent assistance is just a phone call away.

SHARON LEE THOMAS director
Tonquish Creek Manor
Plymouth

Saddened by the response

Editor: "Ignorance is not bliss... ignorance is pathetic."

I am saddened by the response of a well-educated segment of our community in response to a proposed foster home for the retarded.

People still are equating the term "retarded" with "disturbed" rather than "slow development."

Neighbors are worried about the effects of retarded adults on preschoolers. Did they ever stop to think it might be a tremendous lesson in compassion and an educational opportunity to teach about the ill effects of prejudice and that differences exist in human beings?

As for property values, in my opinion, Plymouth Opportunity House serves as an example of a facility increasing the aesthetics of a neighborhood. Furthermore, most people will

not even be aware of the residents as they go about their daily routine.

My sister, Terry Jergens, moved into Plymouth Opportunity House in August after 20 years in a state institution. The tremendous progress and the level of independence she has attained, along with her increase in self-esteem, has been extremely heartwarming to our family and all who know her.

As a teacher for 12 years of the trainable mentally retarded, I can attest to the fact that normalization has to be modeled and taught. Yes, some behavior may seem a little different, immature or bizarre at first, but give these people a chance to learn, develop and grow away from the confines of an institution.

I have seen for myself how the foster facility becomes in fact a "home" in the truest sense — the residents "brothers and sisters in spirit."

Please give the Beech Court house the same chance to meet challenges as Plymouth Opportunity House. We will be a "richer" community because of it.

DIANE JERGENS JANES
Plymouth

Merchants appreciated

Editor: On behalf of the Plymouth newcomers, we would like to thank the Plymouth community merchants for their tremendous support of our spring fashion extravaganza.

Plymouth fever has spread to Newcomers and we all share in the love and pride in Plymouth displayed by a community working together.

Especially expressing appreciation are the fashion show coordinators, Karen Mueller and Janice Paulsen.

CAROLE TOWNSEND
President

learn french
french
by the Alliance Francaise method exclusively taught at the French Institute of Detroit
register now call 292-2750

CASH
Immediately For Used **PIANOS**
• Spinets
• Consoles
• Grands
Call **DAN**
383-2770

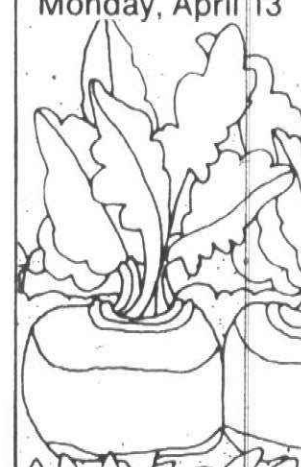
HOME & GARDEN AN UNBEEETABLE GUIDE!
Monday, April 13

My doctor pronounced me cured of cancer. My boss didn't.



My boss didn't understand that I was healthy again.

So I was let go. A lot of people are like my boss. They think that everyone dies of cancer. I thought so, too. Until the American Cancer Society through one of its service and rehabilitation programs helped me return to a normal life.

The ACS also has local units that help Americans who've never had cancer understand it better.

Today, more and more cancer is a curable disease. Ignorance about cancer is curable, too.

SOFT LEATHER cleans nicely by rinsing in a solution of mild soap and lukewarm water. Add one teaspoon of olive oil to increase the softness. You'll get great results when you use Observer & Eccentric Classified Ads to buy, sell or rent something.

SAVE \$\$\$ at American!

Georgia Pacific Shingles

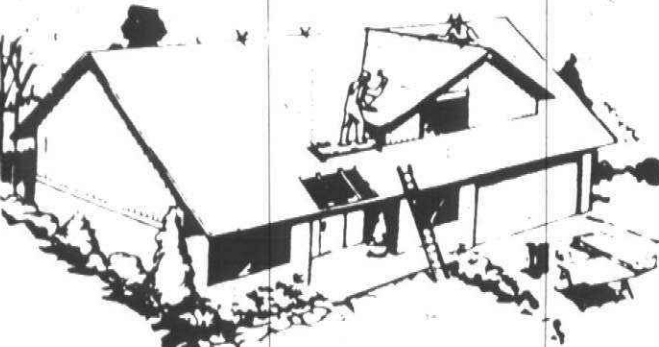

A BUILT-IN SUN ACTIVATED SEALANT BONDS EACH SHINGLE TO THE NEXT. YOU GET MAXIMUM WIND PROTECTION.

10 COLORS 23⁹⁴ sq.



Joint Compound
Georgia Pacific
7⁹⁹
5 gal.

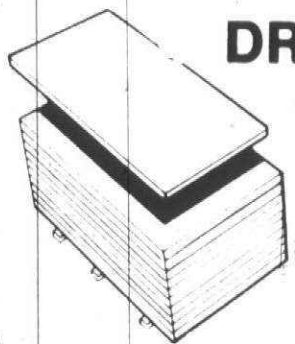

DRYWALL
1/2" - 4'x8' 2⁹⁹
3/8" - 4'x8' 2⁸⁸

STUDS
Economy 2"x4"x8' 78¢
Construction 2"x4"x8' 1³⁸



LUAN UNDERLAYMENT
1/4"x4"x8' 8³⁷

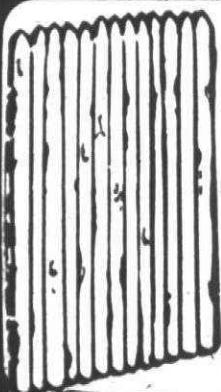

Early Bird Special Stockade Fencing
6x8' Sections #1 Grade 19⁷⁷ C&C
Delivery Available

PLYWOOD CDX SHEETING
1/2" - 4x8 8³⁴

MICHIGAN'S MOST UNUSUAL HARDWARE STORE

American
HARDWARE-LUMBER & SUPPLY COMPANY

Daily 8-6
Sunday 10-4

31245 EIGHT MILE ROAD corner MERRIMAN • LIVONIA • 476-6240

DOUBLE GRAND OPENING

MARCH 14TH & 15TH
NOT JUST A GRAND OPENING BUT A DOUBLE GRAND OPENING FOR TWO UNIQUE NEW RETAIL STORES!

NATIONAL BUSINESS OPPORTUNITY CENTERS
30719 Southfield Rd. Phone: 642-4268

OPEN 7 DAYS A WEEK
Mon-Fri: 8:30 a.m. to 6 p.m.
Sat: 9 a.m. to 6 p.m.
Sun: 10 a.m. to 5 p.m.

First of its kind!
Over 250 businesses you can get into for yourself. Do-it-yourself "start-up" manuals that show you step-by-step how to start your own business • Business books on all facets of small businesses • Motivational books • Self improvement books • Motivational tapes • Hypnosis books and tapes.
If it's independence you seek... relief from worry about layoffs and financial independence... this is the Center that can answer your questions.
National Business Opportunity Center is the licensed dealer, (for Wayne, Oakland, Macomb and Monroe counties), for American Entrepreneurs Association Business Manuals and Entrepreneur Magazine.

NATIONAL PRINT & COPY MARTS
30715 Southfield Rd. Phone: 642-6997

OPEN 7 DAYS A WEEK
Mon-Fri: 8 a.m. to 7 p.m.
Sat: 9 a.m. to 6 p.m.
Sun: 10 a.m. to 5 p.m.

Your one-stop Center for all your needs!

- Instant printing, while you wait.
- 2 color printing.
- Instant computerized typesetting.
- Copy Centers—copies up to 11 x 17, bond paper Special 8 1/2 x 11 copies 3¢
- Xerox color copies—Now you can reproduce color photos, color artwork and convert your slides to 8 1/2 x 11 bond color copies.
- Complete line of office supplies

8 1/2 x 11 BOND COPIES
3¢
SPECIAL

FREE GIFTS!

First 200 people registering at each store on opening days will receive special free mementos.

PLUS—You can win one of these gifts:

- Gourmet dinner gift certificate for 2 at the Bijou. (next door)
- Gourmet lunch gift certificate for 2 at the Bijou.
- 60 free car washes at the Boron Car Wash. (next door)
- 200 Whopper® Sandwiches at Burger King (next door)
- Prescription sunglasses
- Calculators
- Desk sets
- Cameras
- Clock pens
- Perfume
- Personal stationery
- Gift certificates
- Discount certificates

Over 300 prizes to be given away during our grand opening days celebration.

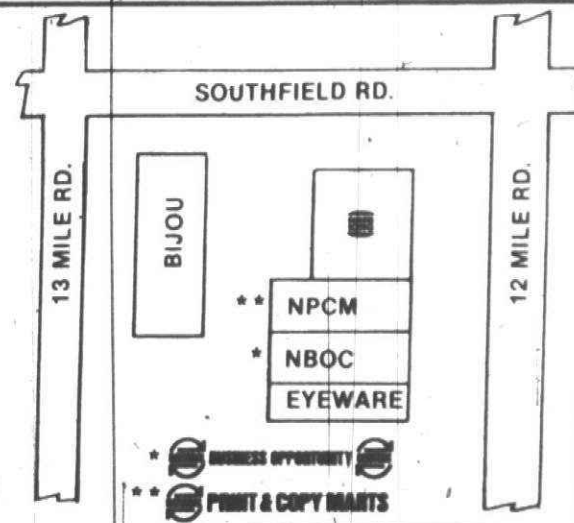

461 S. Main
Plymouth, MI 48170
(313) 459-2700

Darlene Stinson editor
Nick Sharkey managing editor

John Reddy general manager
George Hagan advertising director
Fred Wright circulation director

Philip Power chairman of the board
Richard Aginian president

14A(C)

Thursday, March 12, 1981

Where's the heroism in Flint tax rebellion?

The tax rebels in Flint are making national news for their supposedly heroic stand in refusing to pay federal income taxes.

Ironically, many of the tax rebels are auto workers. One wonders where they were when Congress was approving billions of dollars in Trade Readjustment Act money for their co-workers who were laid off in the last two years.

Their anti-tax thinking suits the conservatives in D.C. just fine. They want to cut the budget, and they want state and local governments to start paying what the feds have paid for previously.

Fiscal conservatives argue that we pay too high a price to have a federal bureaucracy siphon money from income tax to send back to the states in revenue sharing.

It's hard to argue with that kind of logic but — not impossible.

THE RESULT of their thinking would emphasize regressive taxation.

Let's take it down to the local level.

Canton's budget for 1981 includes \$306,000 in federal shared revenue and \$195,000 in other federal aid. State shared revenue includes \$1.3 million from sales tax, \$310,000 from the state income tax and \$20,000 from the single business tax. That adds up to \$2 million.

Locally, the township expects to collect \$1.04 million in property taxes and \$201,000 from a variety of license and permit fees.

The bulk of taxes paid by township residents and businesses go to the schools.

In 1980-81, the Plymouth-Canton Community Schools expect to pull in \$30.6 million in local tax revenues. Canton pays a higher percentage of taxes to the Plymouth-Canton Schools than any of the districts' four other municipalities.

The school district expects \$6.1 million in state aid this year and \$400,000 in federal assistance.

Canton residents, who are already screaming

about high property taxes, now pay more in local taxes to support the township and schools than they receive from the state and federal government.

INCOME TAX FOES argue that cutting federal and state aid to local units of government would allow more direct taxation at the local level, where you can see what you get.

Unfortunately, it doesn't work that way for a very simple reason.

Police officers, firefighters, teachers and clerical employees expect to be paid fairly equal wages. That is, most police officers don't expect to be paid substantially less if they work in Canton than if they work in Bloomfield Hills.

That's a fairly natural assumption, as the cost of living does not vary markedly from Canton to Bloomfield Hills.

The theory of a graduated income tax is that everyone pays — and at an increasingly higher rate as

income rises. Then the federal administration divides the money. The federal revenue sharing is based on per-capita income. The more income per person, the less money back from the feds.

GETTING BACK to our tax rebels in Flint: With the highest level of unemployment in the state, how would Flint residents pay for police, firefighters, teachers and the other necessary services of a community without some help from the state and federal government?

Ironically, the tax rebels are helping the Reagan Administration sell an economic program that will put more of the burden of community services on the individual communities with regressive and painful property taxes.

Unlike those tax rebels of the Boston Tea Party fame, the Flint rebels are inciting a rebellion that only will result in more of a tax burden on those who can least afford to pay.



Tim Richard

If committees could cure our economy

Back in the gala Eisenhower days of the 1950s, I kept hearing that "when the rest of the nation gets an economic cold, Michigan gets pneumonia." The moral of the story was that Michigan was too dependent on the highly cyclical auto industry.

In 1975, a 24-member Michigan Economic Action Council headed by then-Bendix Chairman W. Michael Blumenthal, opened its recommendations for long-term action by noting:

"However, over time, two undesirable characteristics have come to plague the Michigan economy: 1) an unemployment rate that has remained well above the national average even in boom times during recent years; and 2) a concentration of employment in the durable goods manufacturing industries that contributes to the extreme cyclical fluctuations in the state's economy."

In other words, when the rest of the nation was well, Michigan had a cold; and when the rest of the nation had a cold, Michigan had double pneumonia.

During his final week in office this year, then-Transportation Secretary Neil Goldschmidt sounded a warning that the American auto industry might be reduced to one company, General Motors. Clearly, for Michigan such a prospect would mean permanent triple pneumonia, if there can be such a thing.

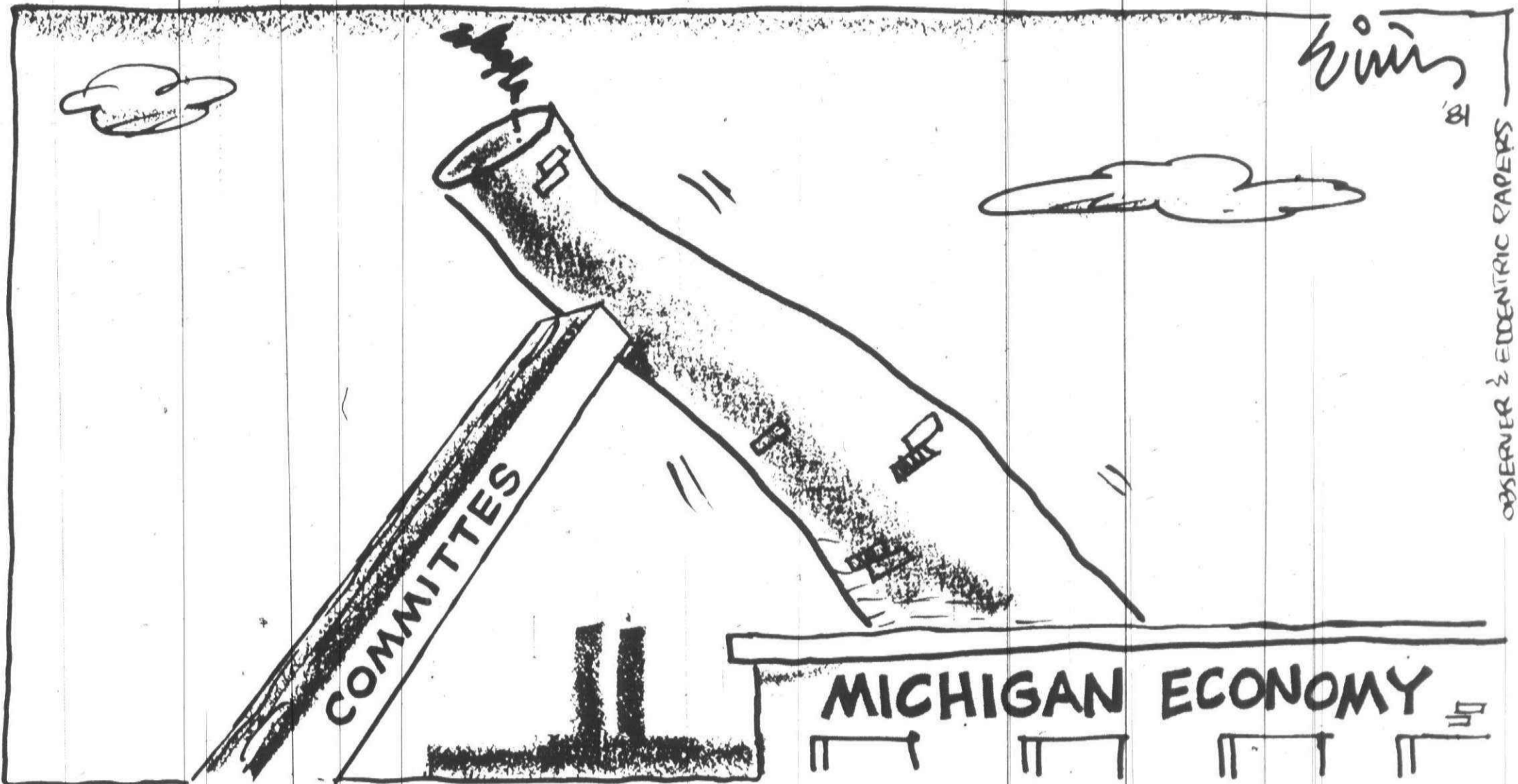

IF STARTING new organizations were the answer, the Great Lake State and Water-Winter Wonderland would be booming like Arizona or California.

I mentioned the Michigan Economic Action Council (MEAC). It recommended creation of a Business-Development Authority, which has been done.

It recommended creation of a permanent Michigan Economic Advisory Council and an Institute for Economic Development. The legislature so acted, but the governor vetoed them during the crunch of things.

MEAC recommended formation of local economic development corporations. That process is going like Gang Busters:

Wayne County has an economic development corporation.

Oakland County has an economic development corporation.

Many suburban cities have economic development corporations or authorities.

Detroit has a downtown development authority and I-don't-know-how-many other such agencies.

THERE IS more.

In SEMscope, the publication of the Southeast Michigan Council of Governments, I read that SEMCOG itself, the Greater Detroit Chamber of Commerce, Detroit Edison Co. and Michigan Department of Commerce have formed a Greater Detroit/Southeast Michigan Economic Development Council.

It sees its first tasks as forming "a policy advisory committee of local elected officials and a technical advisory committee of local economic development specialists."

All of this gives you the impression we're in the process of curing our unemployment problems by putting everyone to work on economic action groups.

But it's not my purpose to be derogatory about economic action groups. Nor is it my purpose to call for still another economic action group to coordinate all the other economic action groups.

A lot is going on. It will be a long time before much of it pays off in big numbers of jobs.

Meanwhile, some attitudes within Michigan will have to be changed.

You've made the oil giant sit up and take notice

Cynics and naysayers, repent. The people are speaking, and the world is listening.

Recall, for a moment, the story of the sergeant and the stubborn mule.

After others fruitlessly tried to get the mule to do their bidding through pulling, tugging and persuasion, the wise old soldier got up off his stoop, picked up a two-by-four and smacked that ornery critter up-side the head.

Well, you've smacked the oil interests up side the head with an overwhelming response of nearly 600 letters in favor of a selective oil boycott. And they're listening with more than a little consternation.

Let me tell you a little about what has happened since the last time we were together.

First, the Shell answer man — you remember him — has volunteered to give his side of the story. You'll read that on these pages in next week's edition. Fair is fair.

Secondly, your effort has gained national attention — from the halls of Congress to the oil capital of America, Houston, Tex.

That's right. The word has spread that citizens in America's heartland are sick and tired of the great American oil ripoff.

THIS SMALL TOWN weekly columnist has spent endless hours on the phone responding to the likes of legislators, oil lobbyists, gas station operator representatives, daily newspapers and oil trade journalists.

Last weekend, I presented more than 200 of your letters to U.S. Sen. Carl Levin.

They all want to know if it's true you're going to fight back.

Like I said, numbers count in this game. Politicians listen when their constituents are unhappy. Oil barons respond when they fear their profits are threatened.

Sure, there is a lot of bravado being bandied about — the I-dare-you-to-boycott-it-won't-do-any-good-kind-of rhetoric.

But one can only ask: If a boycott won't do any good, why does anyone from the oil community take

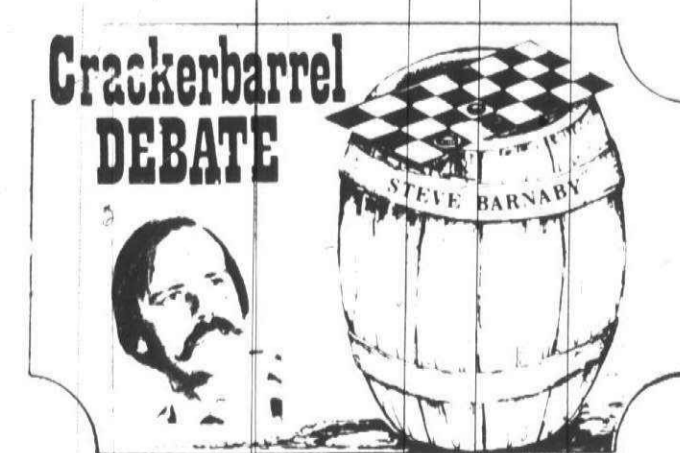

time away from making money to respond?

Oh, we do have detractors. Out of the nearly 600 responses submitted, I received one, under mysterious circumstances, whose author thinks this whole matter is "quite silly."

Personally, whenever so many persons have spoken in unison, I tend to think it is quite unsilly.

Our detractor, who wishes to remain anonymous (again the only one of nearly 600), believes that you and I are talking off the tops of our heads.

WELL, WHOEVER put this guy up to this letter doesn't know me very well — or understand the needs of the American people. He tries to punch holes in arguments of those who object to the present world oil operation.

Suffice it to say I can cite as many experts as the next guy and have just as much documentation from credible sources. Next week I'll do a little hole punching myself.

Besides, it is important that everyone understand just exactly what is going on in the old industry.

But the real question at hand today is what is going to happen with this oil boycott idea?

After all, this situation is tantamount to a battle between David and Goliath.

The truth is that nothing will happen unless you who have expressed an interest do something about

it. As a newspaper columnist, I can make appeals, share ideas and pass on the sentiments of the people to their political and industrial leaders.

But it is the people, en masse, who must take action. And I see real potential of that happening — if you want to do it.

Organization is the key. And from the many letters it is obvious that organization is possible.

Many persons responding are senior citizens, a group whose plight is growing everyday because of the economic hardship thrust upon them.

COUNTLESS senior citizen organizations exist which could back such an effort.

I also received letters from trucking companies which have been wounded by the oil price increases. Remember we're all affected when truckers, who get about three miles to the gallon with their vehicles, have to pass that increased cost of diesel fuel on to us in shipping costs and delivered products.

Union members also responded in great numbers. Well, how about it, UAW, AFL-CIO and Teamsters? These are your members who feel they are getting the economic screws put to them.

So you see many organizations exist which could take up the cause. But you're going to have to get on them about it. Any organization, no matter how much it purports to work for the benefit of its members, must be prodded into action.

Even more important are your neighbors, friends and relatives. Through your letter writing efforts, you have shown that support is deep.

Now the real work begins.

The life of a boycotter can be frustrating and a lot of hard work. But when you think about it, paying \$2 or \$3 a gallon for gasoline can be even more painful.

Those who want to see this boycott idea succeed, go out and knock on your neighbor's door. Organize meetings. Plan a strategy. Set a timetable.

IF ORGANIZATION work is done correctly, the necessary funds will evolve to fight the oil interests. The price of a tank of gas from each member, or even half a tank, would do the job to print bumper

stickers, buttons and the necessary literature to spread the word.

Encourage your legislators to take action. Perhaps the government controls were too much for oil companies to bear and did have a negative impact on oil prices.

Some very reputable persons believe that if the U.S. government did the negotiating with the OPEC nations, instead of each company cutting its own deal, the price could be brought down.

One big problem in this oil crisis is that it flies in the face of our free enterprise, free market system. The OPEC cartel has us on the ropes and it knows it.

Of course, the domestic oil companies aren't exactly squeaky clean either. In their vertically structured industry, competition is nearly impossible.

Vertical structure means that oil companies, mostly the majors, control the product from the well head to the gasoline pump through subsidiaries.

It sort of keeps the money all in the family.

Tell your legislators you're tired of that kind of nonsense and want a change.

BUT, MOST IMPORTANTLY, if you believe in this effort, don't give it up. Keep the letters rolling in and tell the world the good old-fashioned American spirit is alive and well and willing to do the job at hand.

Remember, if you don't do anything about it, nobody else will.



Did you know that Michigan has 400 major bedding plant producers, located mostly in metropolitan Detroit, Kalamazoo and Ottawa counties?

Let feds negotiate with OPEC

By STEVE BARNABY

The United States could work itself out from under the economic strain of spiraling oil prices and uncertain supplies if the federal government were allowed to negotiate with foreign oil interests, according to Robert Amori, an oil jobber for Barnosky Oil, Wyandotte.

But members of the American oil family find themselves working at odds with each other rather than in unity, according to the Farmington Hills resident.

Battle lines are drawn between the major oil companies, station operators, independent oil companies and the jobbers who find themselves in the middle of the fray.

OIL JOBBERS buy surpluses from the major companies (Exxon, Shell, Gulf, etc.) and sell to independents. But Amori said the majors now are putting the squeeze on jobbers.

"The majors are trying to commit us to buy surpluses, but they don't want a contractual relationship," said Amori.

"The refiner doesn't want to move products to the independent when he doesn't have to."

"They'll sell to us, but they don't allow enough margin to pay our bills."

Amori said major oil companies claim they must sell their gasoline for five cents more a gallon than independents because of the majors offer such extras as service bays and credit cards.

"But when I go to them and want to buy it for a nickel less, they won't do it," he said.

INSTEAD, the majors will sell jobbers gasoline for only 1/4 of a cent less.

"But it costs me three cents to get it out on the street and make some profit," said Amori, meaning that independent self-serve stations are forced to raise their prices. The higher price inhibits competition and costs the consumer more.

The result, Amori said, is that independents are losing their spot in the marketplace.

Jobbers have a significant role on

the American oil scene, because they sell 80 percent of fuel oil and 35 percent of gasoline in the nation, according to Amori.

ALTHOUGH HE favored federal deregulation of the oil industry, Amori does see a role for the national government in the oil business.

He supported a bill introduced two years ago by U.S. Rep. William Brodhead, D-Detroit, which would have had the federal government negotiate for overseas crude oil.

In that way, American oil companies would avoid the practice of individually negotiating with the OPEC nations and making separate deals.

"That way we could establish some kind of balance of trade in which we could barter with foreign nations for what they needed," he said.

BUT THAT BILL went by the way-side when the Carter Administration opposed it. And Brodhead sees little hope of reviving such a concept under the present Reagan Administration.

"There is a feeling in Washington that regulation is unsound," said the 17th District congressman. "The price is going to continue to go up. The doctrine of the (Reagan) administration is that it is good that it is going up."

But Brodhead believes his concept was in step with the free market philosophy.

"What I was thinking was that it isn't inconsistent for the government to be the purchaser in the free market. The government could negotiate for a lower price," he said.

Amori believes this concept to be sound.

"You can't divorce the government from a resource that is so important to the nation. But we've got to find a way to counter the (OPEC) cartel," he said.

Even that could be difficult, he added.

The move toward energy independence could backfire.

"BECAUSE OF the cartel, we're not working in a free enterprise system," he said.

Amori explained that if domestic oil companies invest money to develop shale oil — an expensive process — it would have to be sold at today's going OPEC rate — between \$37 and \$40 a barrel.

But OPEC at present is able to produce its oil at \$1 1/2 to \$4 a barrel. The rest is profit. That leaves open the possibility of OPEC's reducing the price of their oil in the future, leaving American domestic producers out in the cold — and the U.S. forced to go back to OPEC.

'GOTCHA!'

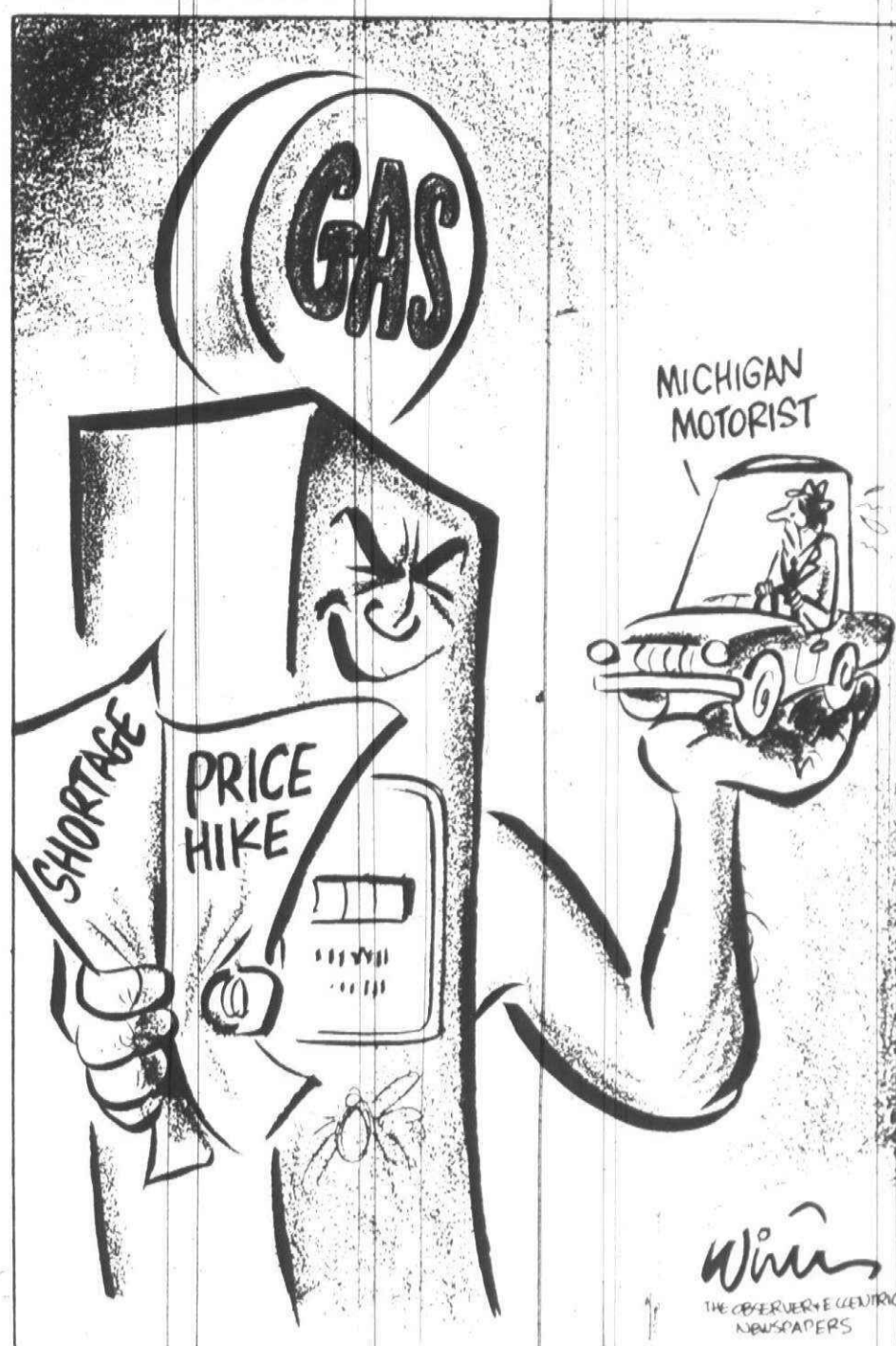

Boycott would rip dealers, not big oil firms — Shipley

By STEVE BARNABY

The only persons harmed by a selective boycott of an oil company would be gasoline station owners.

That's the word from Charles Shipley, who heads the Retail Gasoline Dealers of Michigan. The major oil companies' profits, \$30 billion in 1980, virtually would be unaffected by a local effort, he said.

"If this boycott was 100 percent successful, it would destroy 30 or 40 small businessmen," said Shipley in reaction to a reader response to an Observer & Eccentric survey. That survey revealed that a majority of respondents who wish to boycott an oil company would prefer it be Shell Oil.

ALTHOUGH DEFENDING station operators, Shipley admitted there is no love lost between him and the major oil companies.

"I've been fighting with them for years. Every year oil executives get up on the Fourth of July and talk about the free enterprise system, and then the rest of the 364 days they don't participate in it," he said.

The real profit from oil goes to the major oil companies. Station operators earn about five cents a gallon, Shipley said. Out of that the operator must pay his employees, the utilities and rent, which can range anywhere from \$2,500 to \$3,000 monthly.

"They (station operators) provide a valuable service to the community. If their business is reduced for 30 days, they would go broke," he said.

WHILE STATION operators of major brand names are theoretically independent, said Shipley, they are actually at the mercy of the company whose sign they display.

"In reality, he can't shop around for a product. If he does look elsewhere, he can be shut down," he says.

"An operator could cover up the brand name and buy an unbranded product. But even most of those are produced by the majors," said Shipley.

"He (the operator) would lose his lease, and Shell wouldn't take his credit cards," he says.

THE REAL problem with oil prices today, Shipley said, is that the American consumer was spoiled by the "cheap" oil of previous years.

"They should get rid of their gas hogs and drive fuel-efficient cars," he said.

If consumers would drive more fuel-efficient cars at today's oil prices, he says, they actually would be paying less a mile to drive than when gas cost 70 cents a gallon.

Shipley also blamed America's gasoline problems on the attitudes of the American auto industry.

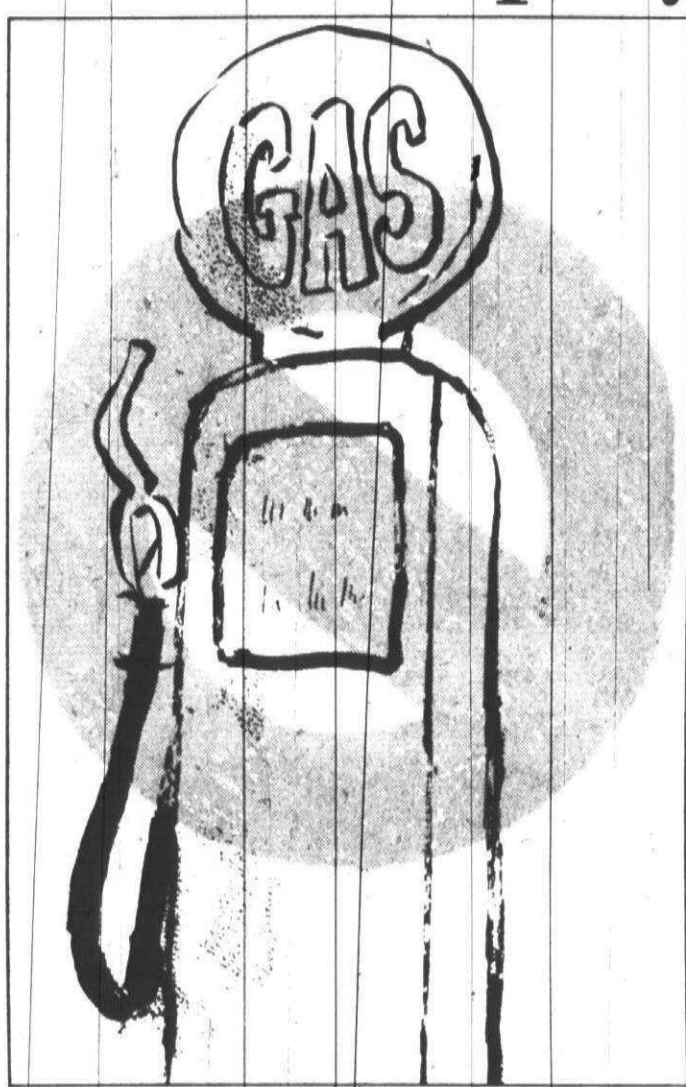

"The handwriting was on the wall. But big cars were making them money even in 1974 and 1975," said Shipley.

Woe at the pump

Prices up 10% in '80, 12% in '81

We all know we're paying more, driving less and cringing every time we see the new numbers posted on the gasoline station tote boards.

It may not be in the \$2.50-to-\$3 range that Europeans are currently paying for petrol, but in the last year, the average price of a gallon of no-lead gasoline in the metropolitan area has risen from a little over the \$1.30 mark to pretty close to \$1.50.

Each week the Automobile Club of Michigan gathers figures from stations along major highways outstate and from many outlets in metropolitan Detroit to compute its average gas prices.

THE FIGURES aren't surprising. According to AAA, the average price of no-lead gasoline in Detroit in 1980 rose by 12.5 cents per gallon, or more than 10 percent. That left the average price on Dec. 31, 1980 at \$1.339.

In the first nine weeks of 1981, however, the rise has been even more dramatic. From Dec. 31 through March 4, the price of no-lead in the Detroit area has risen by almost 16 cents to \$1.496. That increase represents a 11.7 percent hike.

Figures for regular gasoline are similar: On Dec. 31 the average price in Detroit for a gallon of regular gas was \$1.286, and on March 4 it was \$1.445. That's a 15.9-cent increase, or 12.4 percent.

The following chart outlines the AAA gas price figures for the last nine weeks in the Detroit area:

Detroit gasoline prices Dec. 31 to March 4

	Regular	No-lead
Dec. 31	128.6	133.9
Jan. 7	129.1	134.5
Jan. 14	131.2	136.4
Jan. 21	133.1	138.2
Jan. 28	134.0	139.3
Feb. 4	135.2	140.5
Feb. 11	139.9	145.1
Feb. 18	141.9	147.1
Feb. 25	143.3	148.5
March 4	144.5	149.6

Smiley Brothers
A TRUSTED NAME IN MUSIC

The finest keyboard products available!

- Baldwin pianos & organs
- Hammond & Allen organs
- Marrant: Pianocorder "memory" pianos
- Young Chang grands & consoles
- Sabathil harpsichords
- Select used instruments

Dearborn, Telegraph & Ford, 278-1324
Rochester at 1448 N. Roch. Rd. 852-8238
Birmingham at 1016 N. Hunter, MI. 7-1177

CONNOLLY'S
JEWELERS since 1916
PAY
CASH
for
Gold and Precious Gems

Deal with a reputable source who will carefully advise you with the disposal of your Gold and Precious Gems.

Whether it is one piece or an entire collection, bring your 10K, 14K, 18K, or 24K Gold jewelry and scrap or any Precious or Semi-Precious Gems, mounted or unmounted, to Connolly's Jewelers.

ROCHESTER: 614 Walnut Street, Walnut Blvd. 852-4460
DEARBORN: VILLAGE HALL 375-9100
FISHER BUILDING (Detroit): 128 Fisher Building 872-3580

DIP INTO WORD PROCESSING IT COSTS SURPRISINGLY LITTLE WITH **COM SCIENTIFIC**
A Mason Company

An Ohio Scientific Word Processing system will double your typists output (and that's a conservative estimate!) Make last minute changes quickly. Insert new material; delete old, correct errors easily.

Prices starting at \$4,000 (includes printer & monitor)

COMPUTER CONNECTION
38487 Grand River Farmington Hills • 477-4470
Mon., Thurs., Fri. 10-8; Tues., Wed., Sat. 10-6

Grand Opening
New, Enlarged Home Design Center - Orchard Lake & 14 Mile Center

DRAPERY
• Riverbreak
• Eagle Mountain
• Jet Stream
• Reflections
• Pathways
• Side to Side Comforter
• Sidelines Comforter
• Puffin Comforter
• Mystic

custom draperies
SAVE UP TO **40% SAVINGS**
Labor Special \$6 per panel UNLIMITED
ON FABRICS
• Styling with imagination
• Sensible prices
• Decorator fabrics
• Firm workmanship
• Direct mill buying

HORIZONTAL BLINDS
80 Decorator Colors
"BALI"
DESIGNER BLINDS 40% OFF
Freight or Handling Chgs.
CUSTOM WOVEN WOODS 45% OFF
CONCORD AND WESCO

bath accessories for the holidays and for gifts
• Fieldcrest Towels
• Padded Seals
• Towel Bars
• Wood Accessories
• Ceramic Accessories
• Bath Rugs
• Wicker Shelves
• Hampers
• Shower Curtains
• Wall to Wall Bath Kits
• Stylebuilt

VERTICAL BLINDS
50% OFF
Decorator Cloths • PVC
• Macramé
• No Handling • No Handling Charges

DRAPERY BOUTIQUE COUPON
ALL WALLPAPER 30% OFF
Any book — Any group in our library
Saturday, March 20, 1981. Offer expires
cepted. Coupon must be presented upon
placing order only.

UP TO **50% OFF ALL IN-STOCK WALLPAPER**

Measuring, Installation & Design Service at nominal charge.

drapery boutique
Since 1969

FARMINGTON TOWNSHIP CENTER: 37041 Grand River Farmington (313) 478-3133 Daily 9:30-6:00 Mon., Thurs. 9:30-8:30 Closed Sundays

ORCHARD LAKE CENTER: 30858 Orchard Lake Road Farmington Hills (313) 626-4313 Daily 9:30-8:00 Mon. & Thurs. 9:30-8:00

The cost of heating your home a year from now may double. Don't wait for wood stoves to double in price. Buy now and save at Woody's.

BIG SAVINGS ON AIR-TIGHT wood burning stoves, fireplace inserts, wood burning furnace add-ons, and pre-fab fireplaces. Don't just think about heating with wood. DO IT! It's cheaper, dependable and can be a warm, pleasurable family affair.

Choose from our large selection. We carry
FISHER • KALAMAZOO • NORDIC • SUPER HEAT • THOR • THERMOGRATE • STOVE WORKS AND MORE

- Free in-home measuring
- Installation available

SAVE ON ALL FIREPLACE GLASS DOORS CUSTOM — 15% OFF STOCK SIZES — FROM 20% OFF

Woody's Fireplace Shops

Livonia 37335 Six Mile Rd., Newburgh Plaza 591-6655

ALL IN-STOCK FIREPLACE ACCESSORIES 25% OFF
Mon., Thurs., Fri. 10-9
Tues., Wed. 10-7, Sat. 10-6
LAY-A-WAY

from our readers

Justice for all empty credo?

Editor:
Those of us who live in Plymouth like to tout our colonial heritage — the flight of our forefathers to freedom from the heavy hand of oppression.
A part of that heritage contains statements like those we make each time we pledge allegiance to our flag "with liberty and justice for all."
I had an experience last Thursday evening which left me wondering where some of us in this community are coming from. In what might be akin to the old New England town meeting, I, and previous to that, members of the staff of Northville Residen-

tial Training Center, were told to leave a meeting to discuss and "receive more information" regarding a proposed home for six mentally retarded adults within the city of Plymouth.
Although a case might be made by those attending the meeting that the NRTC staff did not belong there because they were not residents of Plymouth, that same case could not be made for me. Not only am I a resident of Plymouth, but I also live within the same 1,500 foot radius that many of them do.
Should the group's rejection of the NRTC staff be based upon residence, it seems that one might then ask why people from Livonia were in attendance.
The answer to that I think is clear. It mattered not where you were from, as long as you were opposed to having

persons who are mentally retarded live in your neighborhood. It did matter if you believe in "liberty and justice for all."

PETER D. SCHWEITZER
Plymouth

Dilemma can't be ignored

To the editor:
There is a great need for the people who reject a mentally retarded group home in their neighborhood to take a good long look at themselves.
Depriving this small group of six retarded adults to live in a home, rather than in an institution, creates a dilemma that no one can ignore.
I do not represent the Northville

Center or any other organization. I am just a concerned resident who in the past has had the honor of working with retarded adults in a group home situation.

Placing these people in a "neighborhood" home environment is the greatest thrill of their lives. No one could find better neighbors than these people.

What reason the residents of the Park Lane subdivision have to prevent this home is beyond me. One of the residents states that they "are opposed to the licensing of a business" in their neighborhood. (As stated, the Department of Social Services is licensing the Sixth Area Coalition, which is a non-profit agency.)

This is not a business home, as the people of this neighborhood well know. This would be a home for six very special and lucky people.

What the residents of the Park Lane subdivision fear by having these people live in their neighborhood can only be found within themselves.
DUFF SCHAD Plymouth

Inflation is frustrating

Editor:
These are hard times, and many of us feel frustrated with inflation.

Inflation itself is only a topper to a list of personal problems one may have. These problems often make it difficult to be cheerful. And, when one is downright angry, to whom does he direct his anger?

Mr. Dividock has misdirected his anger towards Evenson's Shell Service, where I am employed. However, his childish ravings and non-logic only show that he misunderstands the reason for full-service gasoline and its higher price.

If you pull up to full service, we pump your gas. We check your oil and anything else under the hood. We replace wiper blades. We put air in your tires — we are constantly putting air in

the tires of people who don't buy gas!
All this is done no matter what the weather is — even "menacing drizzle." (Mr. Dividock certainly has a dramatic pen; perhaps he should be writing ad copy!). The small increase goes, in part, to pay the employees who perform these services.

Mr. Dividock seems to feel the self-righteous need to awaken a "mesmerized" public. However, if he would talk to our full-service customers, he would find that they are not quite as ignorant as he is. People enjoy the service. I often get compliments. Sometimes, I even get tipped.

So, if Mr. Dividock would like to save some pennies, he can pump his own gas, as can anyone at most gas stations. But, if someone else would rather have it done for them, along with any or all of the above services listed, the choice is his. We won't twist his arm.

CHARLES KAZALEH
Gas pumper
Evenson's Shell

A Public Service Announcement FOR PET OWNERS
Emergency care for your pets may be needed at any hour of the day, night, weekends or holiday. The Animal Emergency Room can provide that service.
ANIMAL EMERGENCY ROOM
24423 Grand River (just West of Telegraph)
255-2404



BEAT THE PRICE INCREASES WITH BIG SAVINGS AT
Greene Bros.
WINDOW SHADE CO.
Levelors 30%*
Bali & Flexalum 40%*
25% Savings on other fine Greene Bros. products.
Plus wallpaper at everyday 25% savings.
no freight or handling charges
- Call the Store Nearest You -
Old Orchard Shopping Center 15150 W. 7 Mile Rd.
Maple Rd. at Orchard Lk. Rd. 342-8822
626-2400
Open Mon. thru Fri. 10-5 Sat. 10-4 Mon. thru Fri. 8:30 to 5 Sat. 9 to 3
*Please note - no freight or handling charges on sizes up to 84x84 - installation available at additional cost - manufacturers suggested retail prices go up effective March 26th. Offer expires 3/31/81.



STAINED GLASS SUPPLIES
Michigan's Best Selection
CLASSES DAY & EVENING CALL NOW
QUANTITY DISCOUNTS
TROY 1073 E. Long Lake Long Lake Plaza 528-1687 Mon-Fri 10-6, Sat. 10-5, Sun. 1-5
WESTLAND 6018 N. Wayne Rd. Westview Plaza 729-9188 Mon-Fri 10-6, Sat. 10-5, Sun. 1-5
LANSING 2224 E. Michigan Ave. Lansing Center (517)332-4597



OUR ANNUAL Spring Sale OF LEES CARPETS

Now, you don't have to wait one day longer for that new Lees Carpet you've been thinking about. Because, right now, we're having a Lees Spring Sale. Every best quality Lees Carpet is on sale. plushes, twists, sculptures in hundreds of colors and textures. Featuring carpets made with the DuPont Antron Advantage. They resist dirt, wear, staining and crushing, even static shock. So, if you've been waiting patiently for the right time to buy your new Lees Carpet, it's here.

ALL BEST-SELLING LINES 15%-32% OFF HURRY, SALE ENDS SATURDAY, MARCH 14.

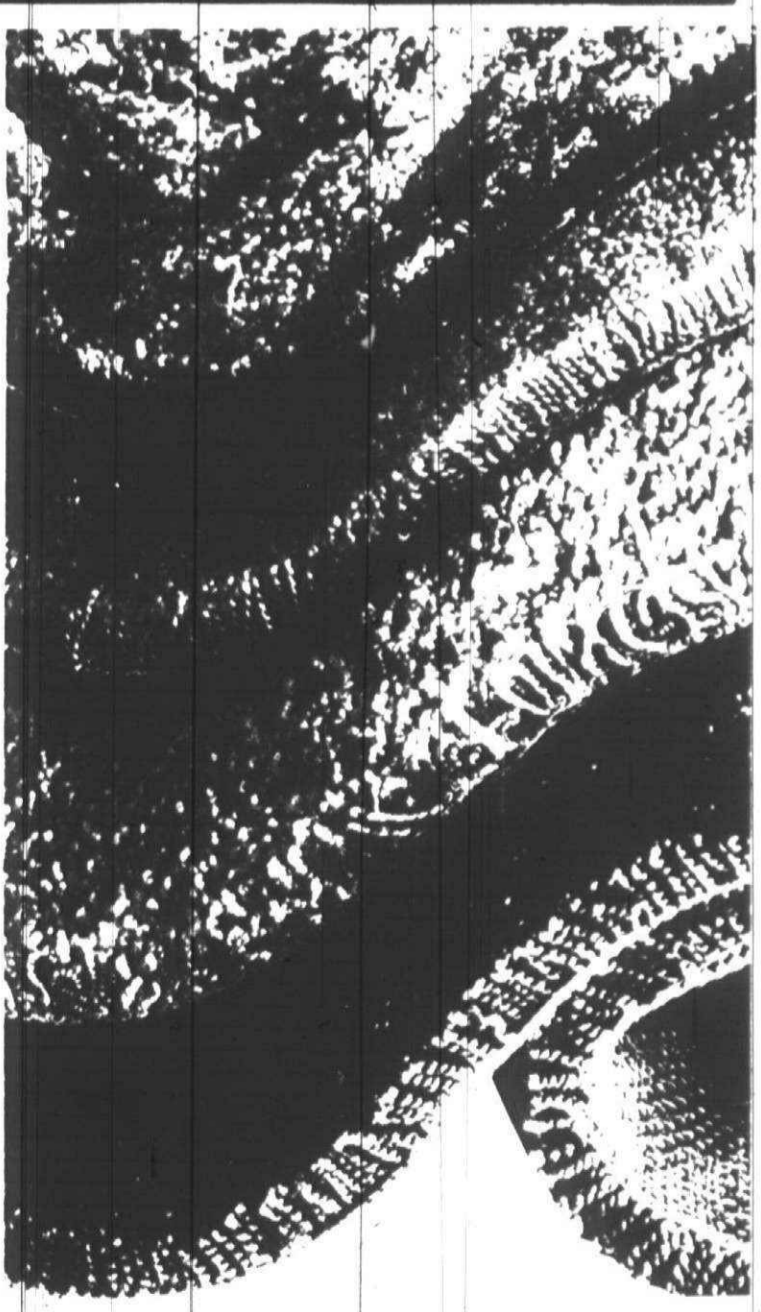

BUY FROM A RELIABLE DEALER LIKE A LIFESTYLE CARPET CENTER DEALER. THE LEES LIFESTYLE DEALER IN YOUR AREA IS LISTED BELOW:

BIRMINGHAM McQueens Carpet 4078 Maple Road 647-5250	CLARKSTON Castles Carpet Center 5930 Mt. Pleasant 625-2100	DEARBORN Main Carpetland 24340 Michigan Avenue 565-8555	LIVONIA A. R. Kramer Company 15986 Middlebelt Road 522-5300	NOVI Novi Carpet 41744 W. Ten Mile Road 348-2622	ROCHESTER McCoy Floor Covering 870 S. Rochester 652-2131
BRIGHTON Rite Carpet Brighton Mall 227-1314	DETROIT Carpet Talk 18915 Harper 881-4808	FARMINGTON D'Martin Carpets and Rugs 34789 Grand River 478-6020	LIVONIA* Rite Carpet 29485 W. Seven Mile Road 476-8360	PLYMOUTH R & B Gallery of Fine Carpets 631 Main Street 459-5040	ROYAL OAK Best Carpet Company 1030 Woodward Avenue 543-5300
CENTERLINE Harpers Carpet Showroom 8044 E. Ten Mile Road 758-2100	TROY Edeh Carpet 1111 E. Long Lake 524-2777	GROSSE POINTE Ed Maliszewski Carpeting 21435 Meck 778-5510	MT. CLEMENS Krausenecks 166 S. Gratiot 463-0585	PONTIAC Spencer Floor Covering 2465 Elizabeth Lake Road 682-9581	TROY United Carpet 3911 Rochester Road 528-1900
LEES CARPETS	UTICA Carpet Dimensions 8220 23 Mile Road 254-2870	WESTLAND Independent Floor Covering 920 Wayne Road 729-6200	WYANDOTTE Jabro's 2801 Fort Street 285-0110	LEES CARPETS	

Joe's Produce
NOW OPEN
WEEKEND SPECIALS THURS-FRI-SAT

WILSON'S LOW FAT MILK \$1.49 Gal.

California Iceberg Lettuce 49¢ head

St. Patrick's Day Special GREEN CABBAGE 12¢ lb.

Washington Ex-Fancy-Large RED DELICIOUS GOLDEN DELICIOUS APPLES 49¢ lb. Hard & Crisp

JOE'S PRODUCE
33152 W. Seven Mile Rd. Livonia
Just east of Farmington Rd. 477-4333
Mon. thru Sat. 10-7 Sunday 10-5

Thursday, March 12, 1981

(C)1B

The VIEW
from
CANTON CENTER

Our cable television was installed Saturday morning. The grandchildren's reaction could be compared only to their parent's excitement when the family's first television set was plugged in many years ago.

We had been expecting the salesman. Earlier in the week, a flyer had announced that Omnicom salespersons would be in the neighborhood.

The Omnicom representative arrived shortly after dinner, and I was waiting for him — ready to respond to any false claims or promises with a big, "Now wait a minute!"

Being a member of the public access channel advisory committee, Hugh Jencks of Omnicom had kept me and other members of the committee posted on installation progress. We knew why sales had been held up until existing wiring had been revamped to handle the expanded 52-channel service.

HUGH PREDICTED the rewiring should be completed by March 1, and the salesmen would be out in full force. His estimate was 3,500 subscribers by the end of May.

"We'll be knocking on 2,000 doors a month and by the end of summer ex-



by
ELLIE GRAHAM



Shenanigans opens Friday

Life may return to normal next week for Canton and Plymouth families whose parents have been caught up in the whirl of rehearsing and planning the arts council's "Shenanigans." The show opens Friday at 8 p.m. in Plymouth Salem High School auditorium for a two-night run. Those who have been involved in all three of the musical revues say this is the best of them all. Persons manning the box office in Plymouth Furniture on Main Street, Plymouth, report ticket sales have been brisk. It will be open from 10 a.m. to 6 p.m. Friday and from 10 to 5, Saturday. Director Ed Horner, left, and Jan Gattoni, who is chairing the show, conferred at a recent rehearsal. (Staff photos by Gary Caskey)



Children's literature is series topic

pect to have 80 percent of Plymouth, Plymouth Township, Canton and Northville installed," Hugh told the committee. It seems that they are running on schedule.

I was not expecting immediate access to the Schoolcraft College channel. Ron Griffiths of SC is on the advisory committee, and these things take time. The college channel will be on the air in the fall, and subscribers will be able to sign up for college credit courses (for a fee). Those interested in the course but not the credits will be able to watch and learn for free.

From the very beginning, we knew the city of Plymouth would not air its commission meetings. Henry Graper, city manager, was emphatic about that. He had been involved in city government meetings which were televised. Every member of the council or commission became so aware of the coverage that meetings dragged on for hours which normally would have lasted less than an hour.

The city will televise special hearings.

THE CABLE TV salesman did not promise immediate miracles. He told what was available and what was forthcoming. He was very businesslike and explained the buys very clearly.

We could have been hooked up the next day, but we settled for Saturday morning, when we were sure someone would be at home.

There had been rumors of sloppy installations — piles of sawdust and wire ends littering the floor. I was going to keep an eagle eye on our installation. And I did.

As my grandmother would have termed it, he was "as neat as a pin."

It turned out to be a great weekend. Pictures on the regular channels were better than ever. We saw some great movies, some fine children's and science programs.

The absence of commercials during a movie takes some getting used to, especially when you've been programmed to head for the kitchen for food and drink during breaks. It does take away from the watcher's feeling of efficiency when there's not even time to toss a load of clothes from the washer to the dryer.

There's the reassurance that if you tune in late and miss the beginning of a movie, it will be shown again.

TALKED TO DENNIS Campbell Monday. He has leased Channel 13 on cable television. He had hoped to start broadcasting last August. But you can't sell time until you have subscribers.

Once they hit the 3,500 mark, Dennis will get started. His studio is up and complete. He said the office is being carpeted this week.

His company, Video Services, will televise locally sponsored programs and news events. He has no fixed deadline but is optimistic about beginning broadcasting in June to Canton Township, Plymouth Township and city of Plymouth, Northville Township and city of Northville.

He has some great programs lined up. There will be the Jackie Gordon Talk Show in the tradition of the late Lou Gordon Show.

Larry Janes will do a gourmet cooking show. Beginning Monday, Sept. 9, there will be the Football Widows Show.

Dennie will do the "For Car Buys Only" show.

Joan Bloss, Newbery-award winning author, lecturer and critic will present a series of three lectures on children's literature in Dunning-Hough Library of Plymouth.

The series will run from 7:30-9:30 p.m. on three consecutive Mondays, March 30, April 6, and April 13 on the second floor of the library on Main Street, south of Church.

All programs will be open to the public, and persons may attend individual or all three lectures. Tickets are \$6.25 per session, or \$15 for the series. The series should be of special interest to parents and educators. It will be sponsored by Plymouth Book World and hosted by the library.

Tickets are available at Dunning Hough Library and at Plymouth Book World (both Forest Place Mall and Penniman Avenue's Volume Two). Mail orders will be honored if received by March 23. They should be sent to Children's Literature Series, Dunning-Hough Library, 223 S. Main Street, Plymouth, Mich. 48170. Checks should be made payable to Children's Literature Series. For information, call 453-0750 or 455-8787.

TOPICS FOR the series are: "Appreciating Children's Books: A Historical

Perspective," March 30; "Exploring Varied Forms of Children's Books from Pragmatic to Poetic," April 6; and "Choosing Special Books for Special Times," April 13.

Since winning the 1980 Newbery Medal and the American Book Award, Joan Bloss has traveled extensively throughout the state speaking at libraries, schools and conferences.

It was her "A Gathering of Days, A New England Girl's Journal, 1830-1832," that earned the Newbery medal which is given annually by the American Library Association for the year's most distinguished contribution to children's literature, and the American Book Award.

Bloss, an Ann Arbor resident, said the increased recognition as a result of the awards has given her more opportunities to speak out and say things she really cares about. She takes children and children's books very seriously, although she is never pretentious. For most of her career, she says she has considered herself as a teacher, one who imparts her love and understanding of books to her children.

But even before she taught, Joan Bloss wrote. Her first poem was published when she was 10. She graduated to plays in high school, then, after earning a bachelor's degree at Vassar and a master's degree at the College of New

York City, she joined the staff of the Bank Street College of Education. The latter is a pioneering institution for the study of child development and education.

AT BANK Street, Bloss was an instructor in children's literature, a member of the Writer's Laboratory, and an associate editor of the Bank Street Readers. Early in her career,

she wrote stories for educational readers published by Bank Street as well as the texts for two preschool picture books, one with a co-author.

From 1970-80, she taught children's literature at the University of Michigan, focusing on books for the pre-reading child. She is U.S. editor of the quarterly, Children's Literature in Education, and writes frequently for other publications.

The author contributed her \$1,000 cash prize from the American Book Award to a group dedicated to the advancement of children's literature and says she is grateful to have the chance to "convert the award into an opportunity to say things I care about."

Bloss spoke last fall to the Plymouth Study Group. Her talk was opened to the public and attracted a SRO audience.



Joan Bloss, prize-winning author, will return to the community to lead a three-part Children's Literature Series. The series in Dunning-Hough Library will be of special interest to parents and educators. Persons may attend a single lecture or all three in the series.

IT'S A DATE...

you, your prom and a gown from Kitty Kelly

A prom to remember begins at Kitty Kelly where you can select from over 200 formal gowns. The colors, the styles, the look you're looking for - we have it all at Kitty Kelly. So make a date with Kitty Kelly today, then bring this ad in, and receive a free fashion garter with your purchase.

Available now at Kitty Kelly, this lovely knitted chiffon gown, featuring spaghetti straps and a silk flower accent. Select from many pastel shades.

Kitty Kelly
BRIDAL SALONS

18029 E. 8 Mile Rd. - E. Detroit 3760 Rochester Rd. - Troy
(Across from Eastland) (North of Big Beaver Rd.)
776-3150 528-3100

25070 Michigan Ave. - Dearborn
(West of Telegraph)
274-9620



They learn brushing and flossing in school

This is National Girl Scout Week. If you know a girl scout or a leader, congratulate them on the fine work they do in our communities every day of the year.

ATTENTION, Annapolis grads! All wives are invited to join in on an evening coffee at 8 p.m. on March 26. For information or details, call Beth Ammons at 453-8252 or Ann Balcolm at 981-2832.

JILL HARRIS is an office manager at one of our fine Canton dental offices. Earlier this month most of our dentists attended a mid-winter convention in Chicago. There were people there from the tri-state area as well as many countries in Europe.

Statistics were given to those who attended, stating that only 50 percent of all people maintain consistent dental care. As office manager, Jill takes a humanistic approach, undertaking ways to make patients comfortable. Studies have been done on ways to help all of us relax before being treated in the office.

Many patients have to have their blood pressure checked and calmed before work can begin. New techniques have been established in endodontics, root canal, prosthodontics, dentures and bridges, periodontics, gums, and radiation.

Radiation is also a controversial aspect of dental care. What is the safe amount of expose for everyone? There are also marketed materials that were not recommended to those at the seminar.

Jill commented that dentistry has always been associated with pain. Along with a clinical atmosphere and being unaware of what is going to happen when you get into the chair, a degree of fear is instilled.

As we all know, you can not bribe an adult with a toy chest full of goodies, but we can continue to gain knowledge of the new methods available in this ever-changing field. Many of us have been kept in the dark as far as the development of theories and breakthroughs.

There are some offices in which we are treated as a customer, not as a personal friend coming in for care and help. Step by step, the procedures are approached with regimented schedules. This, to my knowledge, is no longer common place because we want to know what is happening and what we are spending our money on.

Many options are available to us when we become aware of a problem. The initial steps are immediately confronted, and we usually have various alternatives to consider.

Church to hold home meeting

A meeting on the topic of foster homes for the retarded will be held tonight in the First United Methodist Church of Plymouth.

The meeting will be held for the purpose of providing information to residents of Plymouth interested in the proposed group home for mentally retarded adults at 741 Beech Ct.

Staff from Northville Residential Training Center will be present to provide information and answer questions.

The open meeting will be held in the fellowship hall of the church, which is located at 45201 North Territorial, one-half mile west of Sheldon Road. The meeting will begin at 7:30 p.m. March 12.



Canton Chatter

By KATHY FREECE 981-2027

The most expensive piece of equipment on display at the convention was a \$30,000 Panorex machine. It is an X-ray unit designed to see the whole mouth and entire sinus cavity with only one X-ray. With many dental clinics popping up everywhere, the single office has to be at its best to keep its satisfied patients coming back.

The reason this subject has been utmost in my mind lately is because my

children's elementary school has just taken quite a bit of an entire week to educate all of the students of the services available to them.

The children were asked to brush their teeth with the brush and toothpaste given to them. Then, they were given a disclosing tablet to chew.

The results were startling to the children and teachers alike. It was funny at first seeing everyone with red mouth

and teeth. Everyone was then instructed to pay strict attention to the part of each tooth that the brush had missed.

It was reassuring to discover that an ongoing education is available to many children who do not have this very basic instruction in their own homes. Many parents were not given this specialized instruction at an early age and in such great depth.

If this type of training is not given in all of our elementary schools, it should be. It was a joy for the children to come home from school with their brand new toothbrush and the super experience of the day.

On our last visit to our dentist, my daughter came home with a toothbrush that smelled like a grape popsicle, and my son had one with the aroma of a fresh orange. Every time they brushed their teeth the smell would be highlighted. It is a different approach

to an age-old problem of getting your children to want to brush and floss.

Ballet students' recital Saturday

The students of Aleta Nichols will present a ballet concert at 8 p.m. Saturday in Pioneer Middle School, 46801 W. Ann Arbor Road.

The dancers range in age from 9-12 years. The ballet company, which has six members, will do modern jazz and can-can numbers. Members of the company are Amber Booker, Jenry Breed, Juliet Pásley, Lynne Mathews and Susan Postell, all of Plymouth, and Kathy Hoffman of Canton Township.

Other students from the studio also will perform.

Donation for the concert will be \$2 for adults and \$1 for children.

SPRING SALE

Paint Up Festival

SAVE \$3 per gallon

on

Fuller O'Brien Paint

Save

20% to 50%

on all

Wallpaper Books

drop & match

VILLAGE FASHION MALL
19223 Merriman Rd.
Livonia
477-4633

ONE WEEK ONLY

ALL BEDDING REDUCED STOREWIDE

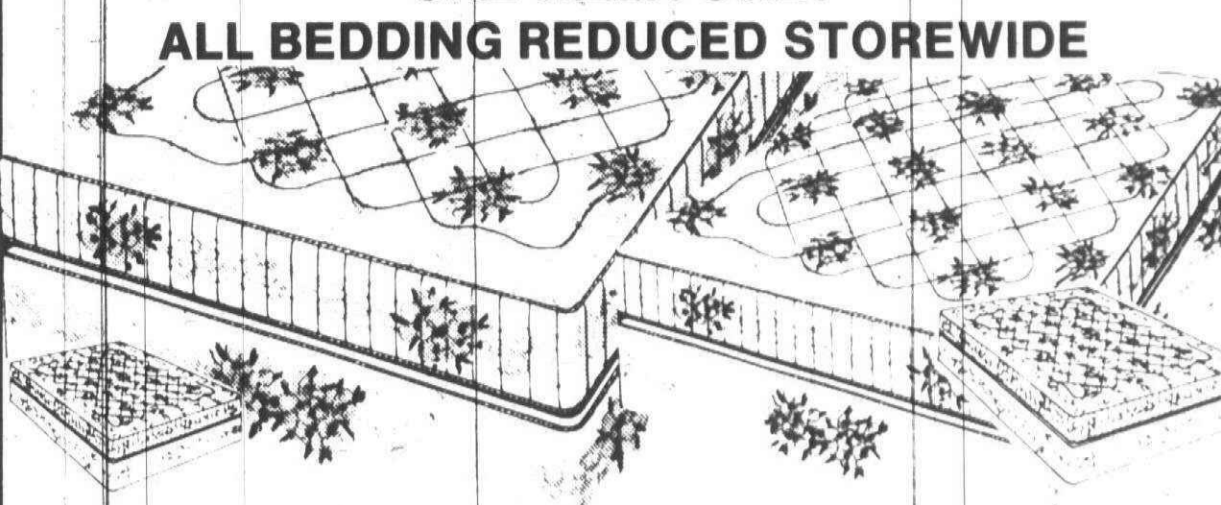

Medium Firm	Firmer	Firmest
Twin Size Each piece	Twin Size Each piece	Twin Size Each piece
\$48	\$58	\$78
Must be sold in Sets	Must be sold in Sets	Must be sold in Sets
FULL - ea. pc. \$58	FULL - ea. pc. \$68	FULL - ea. pc. \$88
QUEEN - ea. pc. \$68	QUEEN - ea. pc. \$78	QUEEN - ea. pc. \$98

HALLMARK FURNITURE
28795 Plymouth-2 Blks. E. of Middlebelt
937-0270 or 427-8600

new voices

Hugh and Ginny Gullede of N. Mill Street, Plymouth, announce the birth of their daughter, Deborah Marie, Feb. 23, in St. Joseph Mercy Hospital, Ann Arbor. They have a son, Daniel Clifton. Grandparents are Mr. and Mrs. W. George Sigler of Royal Oak and Mrs. Virginia Gullede of Newark, Dela.

MAGIC?

We do it with MIRRORS...

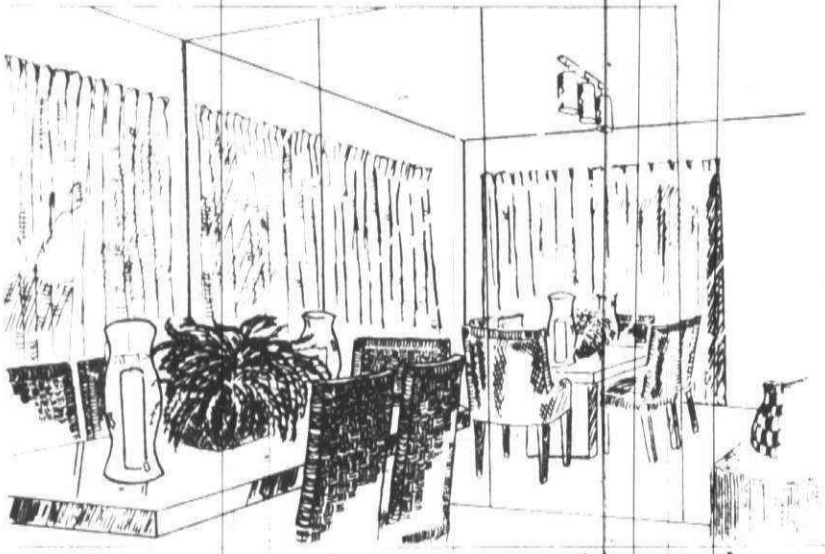

...and so can you. Call for custom ideas and free estimate on full wall mirrors anywhere in your home.

reflections
reflections

The ultimate in mirrors and glass

33491 Seven Mile at Farmington Rd. 476-8410 255-5100

RELAX.



YOU DIDN'T MISS IT.

Because of the demand we have extended our Special, THAT'S RIGHT! Until March 30th you and a friend can enjoy two completely elegant facials for the price of ONE. RELAX, enjoy the luxurious experience of a European facial.

Just clip this ad and bring it in with a friend to any of our convenient locations. * This offer is limited to the number of appointments we can actually accommodate. To insure an appointment for you, please call as soon as possible. *by appointment only. No Gift Certificates

City Magna
Facial Salons

Lienemann 3 at Hunter Square, Farmington Hills • 626-1231
Twelve Oaks Mall, Novi • 484-4551, West to Lovell Tavern,
24901 Northline Hwy., Southfield • 355-0707

Manufacturing Makes the Big Difference



Full length Canadian Lynx from the Gervais Collection, as seen on Channel 9 11 o'clock news, priced at \$6,000 Canadian (\$5,042 in U.S. Funds).

DUTY AND SALES TAX REFUNDABLE, MUCH LOWER PRICES FOR QUALITY FURS. U.S. PRICES BASED ON THE CURRENT 19% EXCHANGE RATE.

	Canadian Funds	U.S. Funds
Raccoon (full length, fully let out)	\$1995	\$1676
Norwegian Blue Fox Coats (full length)	2750	2311
Canadian Cherry Red Fox (full length, fully let out)	4500	3782
Canadian Mink Coats (huge selection in various mutation shades, full length)	from 2995	from 2517
Coyote Jackets	from 1295	from 1088
Fitch Coats	1950	1639
Canadian Beaver (long-haired (full length, fully let out)	1595	1340

One of Canada's largest collection in Mink Coats.

All Gervais FURS
establ. 1935
in Windsor

762 Ouellette Avenue 1-519-253-2111 **2 blocks from tunnel exit Hours: 9-6 Daily**

OPEN SUNDAY 12-6

BOTH STORES OPEN DAILY 9 TO 9

Now...Get Sensational BEDDING BARGAINS

IN THE EXCITING... EXPANDED LASKY "SLEEP CENTERS" at Both Lasky Stores

Super Saving! **\$88** IN SETS ONLY

Deluxe Quality INNERSPRING MATTRESS AND FOUNDATION... COMPLETE SET

Imagine... 252 coils (not 220 as in other mattresses). Imagine... fine 13 1/2 gauge INNERSPRING STEEL construction (not just foam rubber as in other mattresses). You get both twin-size mattress and foundation at this great low price! Full size 54"x75" mattress and foundation... \$98 in sets

BIG 60" x 80" QUEEN SIZE SET

Innerspring Mattress AND Foundation

Super-quality 312-coil construction with beautiful floral cover. Here's Lasky value that defies comparison. You must see it to appreciate the comfort you'll get at so low a price.

BOTH \$138 IN SETS ONLY

Lasky SAVES YOU MONEY On The GREATEST BRAND NAMES

Names you can rely on for night after night of sleeping comfort. We have all sizes, firmness and quality at lowest prices.





SERVICE AND SATISFACTION

We've been satisfying our customers since 1911. Shop us for SAVINGS!

Lasky FURNITURE

BUY AT LASKY PAY AT LASKY

13300 JOS. CAMPAU

Corner of Davison, 3 Minutes E. of Woodward TW 1-7000

29055 PLYMOUTH RD.

1 Block East of Middlebelt Road Phone 937-0300

WE HONOR VISA AND MASTER CHARGE CARDS

30 dealers

Nordells plan show for antiquers

Antiquers Eric and Carol Nordell have planned the kind of antique show they have always wanted to attend. The owners of Countryside Antiques have arranged the Olde Inn Antique Show, 10 a.m. to 9 p.m. Saturday, March 21, and 10 a.m. to 5 p.m. Sunday, March 22 in the Greenfield Room of the Dearborn Inn, Dearborn.

Thirty midwestern dealers, many of whom have never before exhibited in the area, will offer investment and museum quality antiques at the show. They are coming from Ohio, Indiana, Tennessee, Missouri, Iowa, Illinois and Michigan.

The dealers will feature a selection of American and English 18th and 19th century formal period and country furniture, painted furniture, samplers, quilts, coverlets, folk art, baskets, early woodenware, primitives, stoneware, duck decoys, redware, hooked rugs, hand-wrought iron and coordinating accessories.

INCLUDED IN THE \$2 admission fee will be three antique seminars in the General Dearborn Room in the Dearborn Inn.

All three will be on Saturday. They are:

- 1 p.m. — "Fact and Fancy: 200

Years of American Quilts," Mary Kay Davis, instructor at Greenfield Village, lecturer and co-author of "Needlepoint from America's Great Quilt Designs."

- 3 p.m. — "American Folk Art," J. Gordon Humberstone, appraiser, antique consultant and instructor at Greenfield Village.

- 7 p.m. — "Introduction to American Furniture," J. Jordan Humberstone.

The initial \$2 admission fee is good for both days. The Nordells are reminding those who plan to attend of the Sunday brunch available in Dearborn Inn.

A CHAMPAGNE and hors d'oeuvres preview reception for 8-11 p.m. Friday, March 20, at Dearborn Inn, is only for those guests requesting invitations. Reservations are required at \$20 per couple or \$10 single. For reservations call 420-3237.

Among the items in the show will be an 1840 inlaid walnut corner cupboard, an unusual eight-drawer Sheraton chest, pine corner cupboard, Pennsylvania grain-painted cupboard, and a Pennsylvania pewter cupboard.

The majority of the antiques exhibited are required to be at least 100 years old.

There will be Amish quilts, pie safes,

1834 Connecticut deerskin-covered trunk, pine bucket bench, Shaker chairs and a Shaker wagon seat, 1972 stretch-base table, 1800 walnut dry sink with two candle drawers, child's Windsor rocker and a cherry secretary.

The Nordell's shop is on Liberty Street, Plymouth. They have been collecting antiques since they were married, about six years ago. Antiquing has

become a full-time vocation for Nancy, a former high school teacher. It has become almost a second job for her husband who continues his regular work and shares in refinishing furniture, buying for the shop and going to antique shows and sales.

The Olde Inn show will be the first originated and managed by the Nordells. They hope it will become a semi-annual event.

Speight-Johnson

Mrs. Howard S. Hussy III of Tarboro, N.C., and Walter Kinsey Speight of Kinston, N.C., announce the engagement of their daughter, Kimberly Dare

Speight of Edonton, N.C., to Bruce A. Johnson, son of Nancy and George Johnson of Plymouth. The bride-elect is a graduate of Tarboro High School

and attended Eastern Carolina University in Greenville. Her fiance graduated from Plymouth Salem High School and from the University of Kentucky where he majored in pharmacy. He manages a Revco Drug Store in Edonton.

They plan a May wedding in Tarboro.

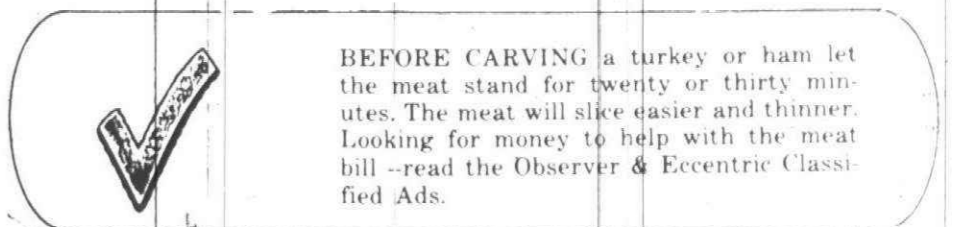

Carol Nordell will be showing some of her own antiques at the the Olde Inn Antique Show, the first arranged by her and her husband, Eric Nordell. (Staff photo by Gary Caskey)

GARAGE DOOR OPENERS
MODEL GS820D
NOW AVAILABLE THE NEW IMPROVED
\$180⁰⁰
INSTALLED
1 Year Warranty

Genie
MODEL GS880D
\$195⁰⁰
INSTALLED
1 Year Warranty

ALADDIN GENIE Sales & Service
722-0610
NORTHVILLE-NOVI
PLYMOUTH-CANTON
FARMINGTON-SOUTHFIELD

FACTORY AUTHORIZED
GENIE
INSTALLING AND SERVICING DEALER

Five Nice USED
PIANOS
\$495
to
\$1095

Weaver Music
383-2770

Bambi Shop
33211 Plymouth Rd. Sheldon Center
Plymouth at Farmington Roads
GA 1-6400

WEATHER TAMER SPRING JACKETS
20% OFF

Save on Boys and Girls Flannel Lined Nylon or Poplin Jackets Sizes Infant to 14.

HER MAJESTY SLIPS
Save on two of our best sellers, sizes 2 to 10. Nylon or Polyester and cotton
\$2.75

SALE ENDS MARCH 21

BOYS & GIRLS

LET'S HAVE LUNCH with the Bunny at Livonia Mall

March 28, and April 4, 11 & 18
11:30 a.m. in the Community Room "G" Entrance

Please reserve _____ Tickets
\$3.00 each. Lunch at 11:30 a.m.
Community Room—"G" Entrance
March 28 April 4 April 11 April 18

Name _____
Address _____
City _____ State _____ Zip _____
Phone _____ Amount Enclosed _____

Make Checks Payable to:
Livonia Mall Merchants Association
20514 West Seven Mile Road
Livonia, MI 48152 Phone: 476-1166
Reservations must be requested 5 days prior to date requested. O&E

Only At **Sherwin Williams Stores**

Annual Wallpaper Sale!
30%-50% off reg. price
Wallpaper and Woven Woods!

Save on Custom Window Fashions

30%-50% off
Over 90 Perfect Touch™ Custom Woven Woods Patterns

30% off
Over 200 Beautiful Colors in Stylish One-Inch Metal Blinds.

(all window decor installation extra)

Save! Over 1500 Fashionable Wallpaper Patterns!

30% off
Beautiful patterns found only at Sherwin-Williams Stores.

Choose from our fourteen exclusive books including:

- Washable
- Strippable
- Scrubbable
- Pre-Pasted
- Fabric-Backed Patterns

SPECIAL! 50% off
Natural Grasscloth Wallcovering

(wallpaper Sale ends April 4)
(wallpaper packaged in double and triple rolls)

Special Carpet SALE!

On Sale **\$5.99 - \$9.99** Sq. Yd.

Values from \$7.99 — \$14.99 Sq. Yd.
(padding and installation extra — not available at all stores)

Sale ends March 21 unless otherwise noted

©1981, The Sherwin Williams Company

SHERWIN Williams

INKSTER
PLYMOUTH
REDFORD

27185 CHERRY HILL ROAD
863 PENNIMAN AVE.
SEVEN GRAND SHOPPING CENTER

278-8350
453-7671
533-5230

MasterCard VISA
Sherwin-Williams Charge Plans Available

clubs in action

CENTENNIAL CB ST. PATRICK'S DAY DANCE
The Centennial CBers' St. Patrick's Day dance will be from 8 p.m. to 1 a.m. Saturday in the Odd Fellows Hall on Elizabeth Street at Ann Arbor Trail, Plymouth. It will be open to the public with "Shadows of Country" providing music for dancing. It will be BYOB with beer setups and snacks available. Donation will be \$7 regular and \$5 for senior citizens. Proceeds will go to the Ann Arbor Burn Center. Tickets may be purchased in advance by calling 455-2894 or 420-0614, or at the door.

AMERICAN HISTORICAL SOCIETY OF GERMANS FROM RUSSIA

German Americans who trace their ancestry to Russia will meet at 7:45 p.m. Thursday, March 19, in Room A-205 at Lawrence Institute of Technology, 10 Mile Road at the Lodge Free-

way, Southfield.

A new member of the society, Arthur Knoff, will share some of his experiences as a resident of Russia. Knoff, like thousands of others who fled Russia to escape persecution, joined the chapter following a national convention of AHSGR in Dearborn.

Person interested in learning more about the chapter and its activities may call Henry J. Felker, chapter president, 459-6675.

WOMAN'S CLUB BENEFIT

The Woman's Club of Plymouth will have its spring benefit Monday, March 30, in First United Presbyterian Church of Plymouth, Church Street at Main, Plymouth. Boutique will open at 11 a.m. when guests are invited to browse, buy and sip punch.

Salad luncheon will be served at noon and cards of player's choice will

follow. There will be prizes and a money tree.

Donation is \$4. For reservations call Linda Pawling, 420-2094.

SUNSHINE GARDEN CLUB

Members of the Sunshine Garden Club will meet at 7:30 p.m. Tuesday, March 17, in the home of Marsha Livermore. Co-hostess for the evening will be Jan Harris. The program will be a discussion on roses led by Bruce Romant.

DAR SANDWICH LUNCHEON

The Sarah Ann Cochrane Chapter of the Daughters of the American Revolution will meet at noon Monday, March 16, at the home of Mrs. Don Urquhart. Following the sandwich luncheon, the nominating committee will present its slate of officers for the next year. Mrs.

Charles Meyers, Mrs. John Nobel and Mrs. Lester Robinson will assist the hostess.

The program of the day will be a talk by Mrs. George Hyma of Bloomfield Hills, state chairman of the DAR schools. Her topic will be "The Kate Duncan Smith DAR School of Grant, Ala. and the Tamasse DAR School of Tamasse, N.C."

Those interested in knowing more about the DAR may call Mrs. Gerald Campbell, 464-1154.

PLYMOUTH RNS

Plymouth Registered Nurses Association will meet at 7:30 p.m. Monday, March 16, in Plymouth Township Hall, Ann Arbor Road east of Lilley. Trooper Robert Garcia of the Northville State Police Post will be guest speaker. His topics will be personal safety and the drug scene in high schools. All registered nurses living in the Plymouth-

Canton Community Schools district are invited to attend.

PLYMOUTH BPW

Plymouth Business and Professional Women will meet at 6:30 p.m. Monday, March 16, at Hillside Inn. The Young Careerist Award of 1981 will be presented. Prospective members or guests are welcome. Call Daisy Proctor, 453-5045, for reservations.

ENERGY CONSERVATION IN THE HOME

Gary Beland of Consumers Power Co. will conduct a brief workshop entitled "Energy Conservation in the Home," 8-9:30 p.m. Monday, March 16. It will be free and open to the public in the Canton Township Recreation Hall, Sheldon Road at Michigan Avenue. The workshop is being sponsored by the People's Church.

LAKE POINTE VILLAGE GARDEN CLUB

Members of the Lake Pointe Village branch of the Woman's National Farm and Garden Association will meet at

7:45 p.m. Thursday, March 12 in the home of Kathy Charlebois. Alva Holk will chair the meeting. Co-hostesses will be Joanne Gray, Elizabeth Gribble and Arlene Pasley.

Guest speaker, Bonnie Kline, will discuss "Looks Good Enough to Eat." New officers will be elected.

WOMEN'S AGLÖW BREAKFAST

Breakfast will be served at 9 a.m. Saturday, March 14 in Cyprus Gardens Restaurant in Harvard Square Plaza. Ford and Sheldon roads, Canton Township. Speaker will be Mary Ticeta. For reservations at \$4 per person call 455-6654 or 459-9720.

PLYMOUTH-CANTON PWP

Plymouth Canton chapter of Parents Without Partners will meet at 8:30 p.m. Friday, March 13 in the UAW Hall on Eckles Road, one block north of Plymouth Road. Afterglow will follow regular meeting. All single parents may attend.

(Continued on Page 5B)

Volunteer has listings

She'll help you find a nursery

By MARGARET MILLER

Some parents look for a nursery school to aid their preschoolers in physical, mental and social development.

Some need a child care center to fill in the hours when both parents are working.

Some have children with special needs and need a school to match.

And all who belong to the growing group of parents choosing some kind of preschool experience for their youngsters want some kind of guidance and some information on how to make their selection.

For all of them, Lindsay Cantoni of Livonia has a file box full of answers.

Mrs. Cantoni is a substitute teacher and a volunteer at the Women's Resource Center at Schoolcraft College and has taken over and updated a service initiated three years ago by the center. The service involves making as complete as possible a listing of child care facilities and nursery school programs available in this area and then making it available to parents who call her Wednesday afternoons.

"Right now I have 65 facilities listed," she said. "I keep records on cooperative nurseries, non-profit nursery school programs, day care centers and regular nursery schools."

"I would like to add information on others in the area, which covers Wayne County and adjoining portions of Oakland County."

Mrs. Cantoni said she tries to keep detailed information on each listing — what age groups are accepted, what hours the school or center is open,



Lindsay Cantoni smiles at daughter Kara, one of the reasons her mother is knowledgeable about nursery schools in this area. (Staff photo by Bill Bresler)

whether snacks or meals are served, whether handicapped children and newborn babies are accepted, what the charges are.

"I do not try to visit them," she added, "and I do not try to evaluate."

"When parents call me, I have answers to their initial questions. I usually give two or three choices and the parents can go from there."

A LISTING of charges is always included in the initial report, she said.

"This is a very real consideration," she added. "If a woman is going back into the job market, she wants to be able to take home more than a few pennies."

The Resource Center's volunteer with the title of Child Care Referral Service Coordinator picked up some knowledge of child care facilities because of her connection with Mother Hubbard Nursery. Her son, Brian, 10, attended that school, and now it is home-away-from-home for 5-year-old daughter Kara.

"Last year a friend of mine was working on the child care listings at the resource center and she asked me if I'd be interested in doing it this year," Mrs. Cantoni said. "I began the updating by sending out a mailing requesting information to 200 schools and centers in the area. The ones that returned answers to questions are now listed, and I hope others will add their names."

She fits in office hours at the Resource Center, 1-2:30 p.m. Wednesdays, between substituting assignments in the Livonia School District. Certified to teach kindergarten through eighth grades, she admitted that "I prefer the little ones."

Mrs. Cantoni said she also has a master's degree in guidance and counseling and "eventually I'll put it back in use."

Meanwhile, she is anxious to supply names of nurseries to parents wanting a choice. Those who could use her help may call her at 591-6400, ext. 431.

"And I like feedback," she said. "I want to know how the recommended nursery is working out. If there is a complaint about the facility, I want to hear about that, too."

CASH
Immediately
For Used
PIANOS

- Spinets
- Consoles
- Grands

Call
DAN
383-2770

Williamsburg
Hair Fashions

PERM SPECIAL
Tues.-Wed. Thurs. Only
\$15.00

FOAM PERM \$30 complete with ad	FROSTING \$25.00 with ad
--	---------------------------------------

538 1042 538 1045

LOSE 15 to 25 POUNDS
In 30 DAYS
Lose Those Unwanted Pounds & Inches Now

SPRING SPECIAL
1/2 Off Initial Fee Expires 3/31/81

- No Drugs
- No Injections

FREE CONSULTATION
Call 427-7111 Now

FREE CONSULTATION
Call 569-5200 Now

Doctors Weight Loss Clinic

Livonia 29588 5 Mile Phone 427-7111	Southfield 29291 Southfield Phone 569-5200
---	--

- Medical Supervision
- Private Counseling

WHY PRE-PLAN YOUR FUNERAL NOW?

Here's why—

FREEZE FUNERAL COSTS FOREVER
Funeral charges are frozen at TODAY'S PRICES. Protect against tomorrow's higher prices.

GUARD AGAINST INFLATION
Who knows about where inflation will end? An inflation-protected funeral pre-paid plan holds today's prices.

SAVE—AS YOU SPECIFY
Guard against overspending. Specify only what you wish to spend.

PREVENT FAMILY PROBLEMS
Save them the burdens of decision during times of stress.

GET PEACE-OF-MIND
You don't have to pre-plan your funeral—but it's a good feeling knowing it's done and your family won't have to worry.

PUBLIC AID EXEMPTIONS
If you ever plan on public aid or supplemental Social Security, set up your funeral pre-paid plan IN ADVANCE, so as to be claimed at least partially exempt. See us for details.

A Family Dedicated to
Funeral Service

Larry, Gerry and Larry Griffin
Licensed Funeral Directors

L.J. Griffin Funeral Home
7707 Middlebelt
(Just South of Ann Arbor Trail)
522-9400

Getting settled made simple.

New-town dilemmas fade after a **WELCOME WAGON** call.

As your Hostess, it's my job to help you make the most of your new neighborhood. Our shopping areas. Community opportunities. Special attractions. Lots of facts to save you time and money. Plus a basket of gifts for your family. I'll be listening for your call.

Welcome Wagon.

CALL
356-7720

We're doing our part to fight inflation!
We have further reduced our EVERYDAY LOW PRICES.....
COME CHECK US OUT!
All of our women's fashions are at least 20-50% off

Dee's
427-6780

Carolina Outlet
28503 FIVE MILE • LIVONIA 5 PLAZA
Between Middlebelt & Inkster
New Spring Hours
10-5:30 Daily; Thurs. Evening till 8 p.m.

"Fur Specialists for over 55 Years"

ARPIN FURS

See the most luxurious furs in the most important new shapes, dramatic new colors! Such as mink in a range of shades, Norwegian Blue Fox, Red Fox, Coyote, Raccoon, Lynx and many others.

Duty and Sales Tax Refunded
Full Premium on American Furs

Furs by ARPIN of Windsor
484 Pellissier St. WINDSOR
(Opp. YWCA, 2 minutes from the Tunnel) 1-519-253-5612

House of Maple & Pine

UNBELIEVABLE VALUE
Solid Hard Rock Maple

\$399
Regular \$599

ONE WEEK ONLY

This is the rolltop desk you've always dreamed of. 51" wide with real wood Tambor. Quality constructed from solid Hardrock Maple at a price so reasonable, you have to see it to believe it.

FILE DRAWERS

MAPLE & PINE

"Michigan's Largest Early American and Colonial Furniture Store"
32086 PLYMOUTH RD. • LIVONIA • 421-0700
Open 9:30-9 Closed Sun. (Bet. Merriman & Farmington Roads - 1 Mile S. of Jeffries Freeway, E. of I-275)

HARRY J. WILL FUNERAL HOMES
REDFORD 25450 Plymouth 48239
LIVONIA 37000 Six Mile Road 48152

James H. Will 937-3670

Send for **FREE Folder**

We want to know more about your **INFLATION-PROTECTED FUNERAL PRE-PLAN**

Name _____
Address _____
City _____ Phone _____



Alpha Delta Kappas plan fashion show

Lorraine Raymer (left) and Adina Rice of Beta Xi chapter of Alpha Delta Kappa admired the oriental flowerprint dress which will be modeled at the sorority's spring luncheon and fashion show in the Mayflower Meeting House. Chapters from three communities are collaborating in planning the annual event which will be at noon Saturday, March 21, with fashions from Clair Kelly and many prizes arranged by members of the educational sorority. For information call 453-3425 after 4 p.m. (Staff photo by Gary Caskey)

(Continued from Page 4B)

PLYMOUTH OPTIMISTS

Plymouth Optimist Club will meet at 7 p.m. Monday, March 16 in the Mayflower Hotel. Bill Saxton will host the program.

SWEDISH CLUB DINNER

The Swedish Club will serve a

steamed codfish dinner including vegetables and dessert at the Finnish Cultural Center, 35200 W. Eight Mile Road, at 3 p.m. Sunday, March 15. Accordion music for listening and dancing will be provided. Advance reservations at \$7.50 are requested by calling Dorothy Lind, 476-4599. Proceeds will go to the club's building fund.

CHILDREN'S LITERATURE SERIES

Children's Literary Series will pres-

ent Newbery Award winning author Joan Blos in a series of three programs at Dunning Hough Library, 223 S. Main Street, Plymouth, 7:30-9:30 p.m. on three consecutive Mondays, March 30, April 6 and 13. Admission is \$6.50 per session or \$15 for the series. They are available in advance at the Dunning Hough or Canton Township libraries or Plymouth Book World, 2 First Place Mall. For information call 455-8787 or 453-0750.

ART RENTAL GALLERY BIRTHDAY SALE

Sixth annual birthday sale of original paintings and prints will be from 10 a.m. to 9 p.m. Wednesday, March 25 in the rental gallery on the second floor of the Dunning-Hough Library. Free admission, prizes and bargains. Birthday cake will be served.



Looking for a tailoring shop?

Men's & Women's Personal Fittings
Lapels narrowed into today's fashions
LAPHAM'S
349-3577
NORTHVILLE
Open Thurs & Fri 9 a.m. to 6 p.m.
Mon.-Tues.-Wed.-Sat 9-6

Prepare for High School in a disciplined Catholic, Christian atmosphere at **St. Sabina School** Grades 1-8
OPEN HOUSE
March 16, 1981 — 7:00 p.m.
• Meet the teachers • See the School
8147 ARNOLD • DEARBORN HEIGHTS
Ann Arbor Trail between Beech Daly and Telegraph
274-5628

OUR BEST ALL HARDWOOD UNFINISHED High Chair
Reg. \$56.00
Now thru Sunday March 15
\$39.95
the Sawmill
HOME OF UNFINISHED FURNITURE
215 E. Main • Northville • 349-8585

Grand Opening Sale UNIQUE FASHIONS

Formerly Claudettes Location

KNIT TOPS Bright ideas in stripe, solids and contrast trims on top of the season. Crewnecks, V-necks, half placket polo and collared tees in cotton, poly blends, 100% cotton and terris. ELSEWHERE: \$8-\$10
Levi's **ARDEE** **QUOTE ME** **eccebay** **NOW \$5 GAUZE & EMBROIDERED SHIRTS** Collect the finest plaids, solids, lures in delicate, embroidered Indian cotton short sleeve shirts. ELSEWHERE: \$10-\$18 **NOW \$5-7**



OUR CONCEPT

Prices: Everyday Savings of 15% to 60% on Name Brand fashions.

Labels: Never cut out... you always know what you're buying.

Selection: Wide variety of styles and fashions in Misses and Junior sizes.

Atmosphere: Pleasant decor... friendly service.

Quality Fashions: Always first quality, never seconds or irregulars.

Convenience: MasterCard and Visa accepted. Layaway and Exchange Privileges.

LINEN BLAZERS Tailored and fully lined to suit your needs. Misses and Juniors in navy, red, white and spring green. ELSEWHERE: \$58-\$70 **NOW \$29**
SKIRTS NOW Kettle and poplin skirts in all your favorite colors! Choose a wrap, button front, crotch waist or belted style. ELSEWHERE: \$20-\$22 **\$10**

Workwear Pants by Blaze & Wrangler
Originally \$20-\$28 **NOW \$15.99**

Levi Bendover Pants \$16.99

PLYMOUTH SQUARE SHOPPING CENTER
(Corner Ann Arbor Rd. & Sheldon Rd.)
44515 ANN ARBOR RD. PLYMOUTH 459-1010

Initially Yours
SPECIAL MONOGRAM SALE
25% OFF A LETTER for 3 or More Garments
Reg. Price **NOW**
\$1.75 per letter — 1/2-3" Size **\$1.50 ea.**
\$1.25 per letter — under 1/2" & full names **\$1.00 ea.**
\$2.00 per letter — over 3" **\$1.75 ea.**
8 Assorted Styles in 5 Different Sizes
PICK UP & DROP OFF — Tues., Thurs. & Sat.
No Appointment Necessary
Prices effective until April 4th
CALL 453-6172
Ask for Donna
We are located in the Plymouth/Canton area

Portrait Studio, Inc.
105 N. Center St. Northville 343-0303
6871 Allen Road Allen Park 383-8803
We use Kodak paper... for a good look.
FOX
We don't forget the groom!
Wedding Coverage From **\$89**

Grand Opening Sharon & Sue's Country Cupboard
Handmade Gifts & Collectibles
• Antiques
• Sewing
• Silk Flowers
• Handmade Wooden Products
Drop in for a Bit of Country Charm
Tues.-Sat 10-5, 'til 8 pm Fri.
904 Starkweather
459-6690

20% OFF All Wallpaper
ALL Wood's Woods Top Ceiling Linings Quality Vinyl Wallpapers
30% OFF All Paint
Interior & Exterior (Painters only)
90% OFF CREATIVE HOME CENTER
187 N. Center (Next to Schrader's)
Northville 343-7118

A DELIGHTFUL REMINDER OF THE LUXURY OF BYGONE YEARS—
cervi's WHITE HOUSE MANOR
43180 Nine Mile at Novi Road
A SPECIAL BUSINESSMAN'S LUNCHEON FEATURED FROM 11:30-3:00 P.M. ...
AND EVENING DINNERS SERVED FROM 5:30-10:00 P.M.
Closed Sundays **349-6200** Reservations Not Needed

Your Invitation to Worship

BAPTIST

BIBLE CENTERED
FUNDAMENTAL
SOUL WINNING
CHURCH



BETHEL BAPTIST TEMPLE
29475 W. Six Mile, Livonia

Sunday School
Morning Worship
Evening Service
Wed. Family Hour
AWANA Clubs - Family Living Classes
News Release

H.L. Petty
Pastor
525-3664
or
261-9276

CALL FOR
FREE TRANSPORTATION

"A Church That Is Concerned About People"

INDEPENDENT
BAPTIST BIBLE
FELLOWSHIP
CHURCH

10:00 a.m.
11:00 a.m.
6:00 p.m.
7:30 p.m.

MARANATHA BAPTIST CHURCH

44815 Cherry Hill Rd., Canton, MI
961-0695

SUNDAY SERVICES:
FAMILY BIBLE SCHOOL 9:45 a.m.
MORNING WORSHIP SERVICE 10:45 a.m.
EVENING SERVICE 6:00 p.m.
MONDAY AWANA CLUBS - Ages 9-13 6:45 p.m.
WED. BIBLE STUDY & PRAYER MEETING 7:00 p.m.
FUNDAMENTAL EVANGELISTIC G.A.R.B.C.

Redford Baptist Church
7 Mile Road and Grand River
Detroit, Michigan
533-2300
9:30 A.M.
"THE DESIRE FOR INNOCENCE"
Pastor Evans



10:45 A.M. Church School for all Ages
6:00 P.M.
Evening Worship
Dr. Weoley I. Evans, Pastor
Mrs. Donna Gleason, Minister of Music

LIVONIA BAPTIST CHURCH

AFFILIATED WITH
SOUTHERN BAPTIST
CONVENTION
32940 SCHOOLLCRAFT
2 BLOCKS EAST OF
FARMINGTON RD.
422-3763

PASTOR ELVIN L. CLARK
Sunday School 9:45 a.m.
Morning Worship 10:45 a.m.
Baptist Training Union 6 p.m.
Evening Worship Hour 7 p.m.
Wednesday Service 7 p.m.

MAIN STREET BAPTIST CHURCH
Affiliated with Southern Baptist Convention
8500 N. Morton Taylor, Canton
N. Theist Pastor 453-4785

Sunday School - 9:45 a.m.
Morning Worship - 11 a.m.
Baptist Training Union - 6:30 p.m.
Evening Worship - 7:30 p.m.
Wednesday Service - 7:00 p.m.
DEAF MINISTRY

PRESBYTERIAN

WARD PRESBYTERIAN CHURCH OF LIVONIA
Farmington and Six Mile Roads 422-1150



Worship and Sunday School 8:30, 10:00 & 11:30 a.m.

"A PARABLE FOR HOSTS & HOSTESSES"
Dr. Bartlett L. Hess
7:00 p.m.

HOLY COMMUNION
"BASIC MEMORY SKILLS FOR CHRISTIANS"
Rev. Douglas L. Thompson
Reception of new members.

Wednesday School of Christian Education
Family Dinner 6:00 p.m., Classes & Choirs 7:00 p.m.

Sunday Service Broadcast
9:30 a.m., Wmuz-FM 103.5

Nursery Care Provided

TRINITY PRESBYTERIAN CHURCH

Meeting at Labster School - Canton Center Rd.
South of Ann Arbor Rd. Plymouth, Mich.

Sunday School for all ages 9:45 a.m.

Worship Services
and Junior Church - 11:00 a.m.

"PETER'S VIEW OF SPIRITUAL GIFTS"
I-Peter: Verse 7-11

Rev. William C. Moore - Pastor
Nursery Provided Phone 455-9550

GENEVA UNITED PRESBYTERIAN
5835 Sheldon Rd.
CANTON
WORSHIP & CHURCH SCHOOL
9:30 & 11:00 A.M.
Kenneth F. Gruebel, Pastor
459-0013

St. Mark's
Presbyterian
26701 JOY RD
Dearborn, Mich.
9:30 A.M.
Sun Sch & Adult Bible
11:00 A.M.
WORSHIP SERVICE

ST. PAUL'S UNITED PRESBYTERIAN CHURCH
27475 Five Mile Rd. (at Inkster) 422-1470

BIBLE STUDY 9:30 A.M.

WORSHIP & CHURCH SCHOOL 9:30 & 11:00 A.M.

"IT'S THE LAW!"
Dr. Whitledge

8:00 A.M. ADULT BREAKFAST

Adult Bible Study, Wed. - 7:30 P.M.
William F. Whitledge and Robert G. Armstrong, Ministers Rev. T.D. Taylor II

FIRST UNITED PRESBYTERIAN CHURCH
PLYMOUTH, MICHIGAN
Corner of Church and Main - 453-6464

WORSHIP SERVICES
9:30 & 11:00 A.M.
CHURCH SCHOOL 11:00 A.M.
(Nursery provided both services)

PHILIP RODGERS MAGEE, Minister
THOMAS H. COOK, Asst. Minister
We have been contemporary since 1839

GARDEN CITY PRESBYTERIAN CHURCH
1841 Middlebelt Rd
Gareth D. Baker,
Pastor
421-7620

SUNDAY SERVICE
9:15 & 11:00 A.M.

"AND THE DISCIPLES
WERE FILLED
WITH AWE"

CHRISTIAN CLASSES
SUNDAY SCHOOL
11:00 A.M.
Nursery Provided

ROSEDALE GARDENS UNITED PRESBYTERIAN CHURCH
Hubbard at W. Chicago 422-0494

Gerald R. Conbleigh and Carol J. Allen, ministers

9:30 & 11:00 A.M.

"OUR LORD BETRAYED"
6:30 P.M. "20TH CENTURY CHRISTIAN
INTERVIEWS JUDAS"

11:00 A.M. Class for the Handicapped
CHURCH SCHOOL 11:00 A.M.

VILLAGE UNITED PRESBYTERIAN
25350 W. Six Mile Rd. 534-7730

Rev. Robert M. Barcus

WORSHIP 10:00 A.M.

WED. BIBLE STUDY 10:30 A.M.

CHURCH SCHOOL 10:30 A.M.

THURS. BIBLE STUDY 7:00 P.M.

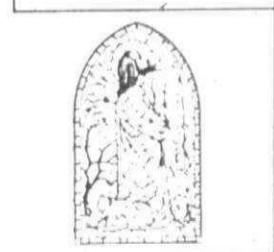

EPISCOPAL

SAINT ANDREW'S EPISCOPAL CHURCH
16360 Hubbard Road Livonia, Michigan 48154
421-8451

8:00 A.M. - Holy Eucharist

9:00 & 11:00 A.M. FAMILY SERVICE

10:00 A.M. Christian Education

Sunday Morning - Nursery Care Available

10:30 A.M. - Wednesday Eucharist

The Rev. Kenneth G. Davis The Rev. R. Scott Krueger
The Rev. Edward A. King

HOLY SPIRIT LIVONIA
9083 Newburgh Rd.
Livonia
591-0211 522-0811

8:30 A.M. Holy Communion

9:30 A.M. Christian Ed.

10:30 A.M. Family Eucharist & Service

The Rev. Emery Gravelle

CHURCH OF THE NAZARENE

PLYMOUTH CHURCH OF THE NAZARENE
41550 E. ANN ARBOR TRAIL PLYMOUTH
453-1525



The Difference is Worth the Drive

9:45 A.M. SUNDAY SCHOOL

11:00 A.M. MORNING WORSHIP

6:00 p.m. SOUND OF SUNDAY NIGHT

WED. 7:00 P.M. MidWeek Service

Nursery Provided at All Services

DETROIT FIRST CHURCH OF THE NAZARENE
21260 HAGGERTY RD.
I-275 at 8 Mile Rd.
FARMINGTON HILLS
348-7600
REV. JAMES D. CONNER



9:45 A.M. CHRISTIAN ED.

11:00 A.M. WORSHIP SERVICE

6:30 P.M. PRAISE & WORSHIP

WEDNESDAY

7:00 P.M. PRAYER & SHARE

NURSERY FACILITIES AVAILABLE

ADULT CLASSES -
Tues. 9:30 A.M. - WHERE IS GOD IN LIFE'S CRISIS?
Tues. 7:00 P.M. - CREATE YOUR FUTURE NOW.
Wed. 7:00 P.M. - Marriage Trials, Tribulations & Triumph
Thurs. 7:00 P.M. - Beginning Art
The Basics of Still Life

LIMITED ENROLLMENT - CALL NOW

First Baptist Church
PLYMOUTH, MICHIGAN
45000 N. TERRITORIAL RD. 455-2300
1/2 Mi. West of Sheldon

9:40 A.M. Sunday School for all ages

11:00 A.M. MORNING WORSHIP

"DAY OF POWER"
Dr. William M. Stahl

6:30 P.M. Evening Worship Rev. John Elliott

Dr. William Stahl Rev. John Elliott

Mrs. Richard Kaye, Music Dir.

HERALD OF HOPE WYFC 1520
Mon. thru Fri. 8:45 A.M.

MORAVIAN

FAITH COMMUNITY CHURCH
46001 Warren Rd., Canton
Just West of Canton Center Rd.
455-7700

Sunday School 9:15 A.M.

Family Worship Service 10:30 /
Nursery Available

Rev. Darryl Bell, Pastor 459-2199

A Protestant Church Serving the Community

For Church Advertising
Call Vel Ellis 591-2300 Ext. 281

NON-DENOMINATIONAL

WORSHIP & SERVE

with
THE SALVATION
ARMY

290 Fairground
Plymouth
453-5464

SUNDAY SERVICES
9:45 a.m. Sunday School
11:00 a.m. Morning Worship
6:00 p.m. Evening Worship

Lt. Bill Harfoot,
Officer

AGAPE CHRISTIAN CENTER

345 North Main,
Plymouth

10 A.M. ADULT WORSHIP

YOUTH/CHILDREN'S CHURCH

6 P.M. Worship
WED. 7:30 P.M. Family Teaching
459-6240

Agape Means The God Kind of Love



Pastors Earl and Bobbie Moore

REFORMED CHURCH IN AMERICA

People's Church
PLYMOUTH-CANTON HIGH SCHOOL
8415 Canton Center Rd.

WORSHIP 10:00 A.M.

YOU CAN REACH BEYOND YOUR LIMITS - GO FOR IT!!!

Nursery Available

Reformed Church in America



Rev. Harvey Heneveld
Phone: 961-0499

CHURCH OF THE SAVIOR

Reformed Church in America

Rev. GERALD DYKSTRA, Pastor

SUNDAY SCHOOL 9:30 A.M.

WORSHIP SERVICE 10:30 A.M.

38100 Five Mile Road West of Newburgh
464-1062 Livonia

LUTHERAN WISCONSIN

Wisconsin Evangelical Lutheran Churches

WISCONSIN LUTHERAN RADIO HOUR
1090 Sunday 10:00 a.m.

In Livonia - St. Paul Ev. Lutheran Church
7810 Farmington Rd.
Pastor Winfred Koelgen - 261-8759
Worship Services 8:30 a.m. & 11 a.m.

In Plymouth - St. Peter Ev. Lutheran Church
1343 Penniman Ave.
Pastor Leonard Koening - 433-3393

Worship Services 8 & 10:30 a.m. • Sunday School 9:15 a.m.

In Redford Township - Lola Park Ev. Lutheran Church
14750 Kinloch
Pastor Edward Zell - 532-8555

Worship Services 8:30 a.m. & 11 a.m. • Sunday School 9:45 a.m.

In Westland - Our Savior Ev. Lutheran Church
Warren at Farmington Rd. Rev. R. Schwab
427-1490 (Office) 427-8119

EVANGELICAL COVENANT CHURCH OF AMERICA

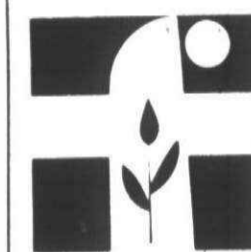

FAITH COVENANT CHURCH

Pastor: Michael A. Hakeen
Associate Pastor: Mary Miller Vikander
Minister to Youth: David A. Rose

35415 W. 14 Mile Rd.
at Drake
661-9191

SUNDAY SCHOOL & ADULT STUDY GROUP - 9:30 a.m.

SUNDAY WORSHIP SERVICE - 10:45 a.m.

UNITED METHODIST

FIRST UNITED METHODIST OF PLYMOUTH
45201 N. TERRITORIAL RD. (300 yds. West of Sheldon)
453-5280 • OFFICE HOURS 9-5 MON. THRU FRI. • 453-5285

WORSHIP SERVICE & CHURCH SCHOOL
9:30 & 11:00 A.M.

John N. Grenfell, Jr.

Frank W. Lyman, Jr. Associate Minister Frederick C. Vosburg Parish Minister

CERRY HILL UNITED METHODIST CHURCH

321 Ridge Rd. - Canton Twp.
So. of Cherry Hill Rd. - Pastor
REV. BERT HOSKING

CHURCH SERVICE
8:45 & 11:00 A.M.

SUNDAY SCHOOL 9:30 a.m.
495-0035

CLARENCEVILLE UNITED METHODIST
20300 Middlebelt Livonia

Pastor Gerald Fisher 474-3444

8:45 a.m. First Worship Service 5:45 p.m. Youth Meetings

10:00 a.m. The Church School 7 p.m. Sunday Evening Service

11:15 a.m. Second Service of Worship 7:00 p.m. Wed. The Midweek Service

Nursery Provided at All Services

NEWBURG UNITED METHODIST CHURCH
36500 Ann Arbor Trail
464-6772

Ministers: Jack E. Giguere Margery Schliecher

Dave Gladstone Director of Youth

Terry Gladstone Director of Education

WORSHIP SERVICE & CHURCH SCHOOL
9:15 & 11:00 A.M.

ALDERSGATE UNITED METHODIST CHURCH
(Redford Township)
10000 BEECH DALY ROAD
Between Plymouth and West Chicago

Rev. Archie H. Donigan

Korean Minister - Choi Yu Hon

Korean Chapel Service - 11:00 A.M.

Worship Services & Church School 9:30 & 11:00 a.m.

Minister of Music: Ruth Hadley Turner - Dir. of Ed. Barbara Caldwell

NARDIN PARK UNITED METHODIST CHURCH
29887 West Eleven Mile Road 476-8860
Just West of Middlebelt Farmington Hills

WORSHIP • SUNDAY SCHOOL • NURSERY
9:15 & 11:00 a.m.

"IS THERE A PHYSICIAN FOR THE WELL?"
Rev. Ritter

Rev. William A. Ritter, Pastor

Rev. William E. Frayer, Assoc.

Mrs. Doretta Miller, Dir. C.E.

Mr. Melvyn Rookus, Dir. Music

ST. MATTHEWS UNITED METHODIST CHURCH
30900 Six Mile Rd.
464-6772

(Belt Merriman & Middlebelt)

David T. Strong, Minister 422-6038

"THE NEED TO LOVE"

9:30 A.M. Church School (Children & Adults)

11:00 A.M. Worship Service

Nursery Provided

CHURCHES OF CHRIST

"A Caring & Sharing Church"
LIVONIA
15431 Merriman Rd.

SUNDAY WORSHIP
11:00 A.M. & 6:00 P.M.

Bible School 10 a.m.

Wed. 7:30 p.m. Worship

Hobart E. Ashby Minister

427-8743 422-8660 or 261-1694

GARDEN CITY
1657 Middlebelt Rd.

SUNDAY WORSHIP
11 a.m. & 6 p.m.

Bible School 10 a.m.

Wed. 7:30 p.m. Worship

Hobart E. Ashby Minister

422-8660 or 261-1694

See Herald of Truth
TV Channel 20 Sunday 9:30 a.m.
Call or Write for Free Correspondence Course

MEMORIAL CHURCH OF CHRIST
(Christian Church)
35475 Five Mile Rd.
464-6772

MARK MCGILVREY, Minister

CHUCK EMMERT Youth Minister

BIBLE SCHOOL
(All ages), 9:20 a.m.

Morning Worship, 10:45 a.m.

Evening Worship & Youth Meetings 6:30 p.m.

UNITED CHURCH OF CHRIST

SALEM UNITED CHURCH OF CHRIST

Oakland at Grand River
Farmington

CHURCH SCHOOL 9:00 A.M.

DIVINE WORSHIP 10:15 A.M.

Church Office 474-6880

Rev. Lee W. Tyler

NATIVITY CHURCH
Henry Ruff at West Chicago
Livonia
421-5406

Worship & Church School
10:00 a.m.
Dr. Robt. H. Jacobson

Hong Kong trip keeps a mission

By MARGARET MILLER

When Grace Van Dyke and her daughter flew west across the Pacific in December, their luggage contained 200 packages of pipe cleaners and 2,000 popsicle sticks.

They also took along bags of alphabet macaroni, glue, transparent tape, plastic berry baskets and a big supply of zip-lock bags. That last item was described by the Plymouth traveler as "the most wonderful things you could imagine."

Mrs. Van Dyke and daughter Lynn, a Pan American Airlines employee based in San Francisco, were not making a standard tourist trip as they flew to

Hong Kong. They were part of PAVE, or Pan American Volunteer Effort, a program for helping in one of several schools for Vietnamese refugees in the oriental city.

She told about her experiences this week in a talk before the United Methodist Women of Newburg UM in Livonia.

In an earlier interview, she explained that the program began because an airline official became acquainted with Sr. Anne Reusch, a Maryknoll nun who was in charge of the school known as Kai Tak in the city's east compound.

"He asked her how the airline could help," said Mrs. Van Dyke, "and they

worked out a way for Pan Am employees and their relatives to serve at the Hong Kong school between trips and on vacations.

"This was the third time my daughter has gone."

HER OWN INVOLVEMENT, said Mrs. Van Dyke, involved a fascinating nine days during which "we worked our tails off."

"We were assigned to help with crafts and do some tutoring in the school that had 500 children, aged 7 to 13. When we weren't teaching the crafts, we were tutoring the children. Because they were refugees, they had moved around a lot and were at various levels. One day I spent working with some recently-arrived children, giving them little math tests to find out where they should be placed in the school. Some could understand some English, some needed interpreters."

The school where she worked was part of a camp which housed some 6,000 refugees, said Mrs. Van Dyke.

Part of the great wave of "boat people" coming out of Vietnam, they were about 80 percent Chinese and the rest Vietnamese, she noted. They stay in various camps in Hong Kong while waiting the opportunity to seek a new life elsewhere in the world — Australia, France, Canada or the United States.

"This country takes the largest number," she noted.

The camp contained 20 buildings made of corrugated metal, said Mrs. Van Dyke. "Three hundred were housed in each room. They slept in triple bunks, three to a layer."

But it was a clean camp, she added, and the people there did their best to keep some pattern to their lives. "They washed their clothes and hung them up there, and each family cooked its meals outside on the grounds."

THE SCHOOL where she offered her services is led by Sr. Anne, described by Mrs. Van Dyke as "a dynamite person" and four paid teachers, three Chinese and one Vietnamese.

"With such a small staff, they could only touch on the basics," said Mrs. Van Dyke, "so the crafts we brought, the kind of things our children would be exposed to at nursery school were new to them there."

"In a school with 500 children there were 12 pairs of scissors and just one box of crayon stubs."

The plastic bags were invaluable, she added, because each day's project could be individually packaged for each child.

One memorable event was a weekend excursion she and her daughter took into downtown Hong Kong with 10 children from the school.

"It was their first subway ride, their first time to use an escalator, their first time in a department store. We bought each of them a notebook, and we took them all to MacDonalds to wind up the day."

But one of the little girls was pretty worried about getting back to the camp, Mrs. Van Dyke said.

"She was a little afraid to get on the ferry boat," she explained. "I guess that was natural after all the time she and her family had spent on a boat."

Thursday, March 12, 1981

*7B



Grace Van Dyke shows off a cotton coat that was one of her few purchases in a helping mission visit to Hong Kong. (Staff photo by Gary Caskey)

ASSEMBLIES OF GOD

CHRISTIAN COMMUNITY CHURCH

41355 Six Mile Rd. Northville 348-9030

11:00 A.M. "THE DEADLY VIRUS"

Irving M. Mitchell, Sr. Pastor
John Luttmann, Youth Director
Dan R. Sluka, Director of Music

WEDNESDAY
7:30 P.M. FAMILY NIGHT
PIONEER GIRLS
Nursery Available

6:30 P.M. "THE KEY TO TRIUMPHANT LIVING"

Brightmoor Tabernacle

26555 Franklin Rd. • Southfield MI
(at 696 & Telegraph - Just West of Holiday Inn)

Sunday School 9:45 AM • Worship Service 11:00 AM
Charismatic Rally - 6:30 PM
Wednesday Prayer & Praise & Lighthouse Youth Service 7:30 PM
Nursery provided at all services

A Charismatic Church where people of many denominations worship together
Thomas E. Trask, Pastor

AIRLANE ASSEMBLY

"Where the drive is worth the difference."
JOHN A. BOOHER, PASTOR

GUEST SPEAKER
Dr. C. M. Ward
March 22-24
Sunday 8:00 A.M. & 10:00 A.M.
Evening 7:00 P.M.

22575 ANN ARBOR TRAIL
DEARBORN HEIGHTS, MICHIGAN 48127
BETWEEN WARREN & OUTER DRIVE

SCHEDULE OF ACTIVITIES

SUNDAY*
8:00 A.M. - Worship
10:00 A.M. - Worship
Sunday School 1-6 grades
7:00 P.M. - Praise Celebration

TUESDAY*
School of the Bible
(1 hour - selective classes)
9:30-11:30 A.M. - Adults
7:00-9:00 P.M. - All Ages

THURSDAY*
7:00-9:00 P.M.
Pentecostal Catechism
Prayer Meeting
Choir
Orchestra
Drama

FRIDAY*
Teen Activities

*NURSERY AVAILABLE

TRI-CITY ASSEMBLY OF GOD

2100 HANNAN ROAD
WAYNE, MICHIGAN
721-6832

11:00 A.M.

Rev. Paul Spence, Guest Speaker
6:00 P.M.

George Brown, Guest Speaker
Mon., Tues. & Wed. at 7:00 P.M.
Jesus Loves You and So Do We
Serving Wayne, Westland and Canton

CATHOLIC CHURCHES

ST. JOHN NEUMANN Parish
44800 Warren Road
455-5910
Fr. Edward J. Bludwin, Pastor

Masses
Sat. 5:00 and 6:30 p.m.
Sun. 8 a.m., 9:30 a.m., 11:00 a.m. and 12:30 p.m.

LUTHERAN (English Synod A.E.L.C.)

FAITH
30000 Five Mile Road
East Livonia
421-7249

Worship - 8:15 and 10:45 a.m.
Bible Classes 9:30 a.m.
Nursery Available
Education Office 421-7359

HOLY TRINITY
39020 Five Mile Road
West Livonia
464-0211

Worship - 8:30 and 11:00 a.m.
Nursery Available
Sunday School 9:45 a.m.
WEEKDAY CLASSES FOR ALL AGES

ST. THOMAS a' BECKET Parish
42424 Castle Court
981-1333
Fr. Ernest M. Partridge, Pastor

Masses at Mildred Field School
4000 Haggerty Rd. South
of Cherry Hill
Sat. 6:00 p.m.
Sun. 9:00 a.m., 10:30 a.m. and 12:00

LUTHERAN MISSOURI SYNOD

CHRIST OUR SAVIOR - LUTHERAN CHURCH

MISSOURI SYNOD
14175 Farmington Rd., 1/4 Mile N. of Schoolcraft
REV. RALPH G. SCHMIDT, PASTOR

WORSHIP SERVICES EVERY SUNDAY 8:00 & 10:30 A.M.
SUNDAY SCHOOL 9:15 A.M.

NURSERY PROVIDED

464-6554 522-6830

GRACE LUTHERAN CHURCH - MISSOURI SYNOD
22630 GRAND RIVER at BEECH DAILY

532-2266 REDFORD TWP.

SUNDAY SERVICES **SUNDAY SCHOOL**
9:15 & 11:00 A.M. 9:15 & 11:00 A.M.

Rev. V. F. Halboth, Jr., Pastor
Rev. Victor F. Halboth, Sr., Pastor Emeritus
Mr. Mark Matthews, Dir. of Christian Education

St. Paul's Lutheran Missouri Synod
20805 Middlebelt at 8 Mile
Farmington Hills 474-0675

The Rev. Ralph E. Unger, Pastor
SUNDAY WORSHIP 8:30 AM & 11 AM
SUNDAY SCHOOL
ADULT BIBLE CLASSES 10 AM
CHRISTIAN SCHOOL Grades K-8
Wayne C. Berkesch, Principal
474-2488

LUTHERAN CHURCH OF THE RISEN CHRIST
Missouri Synod
46250 ANN ARBOR ROAD
PLYMOUTH

Kenneth Ziebk Pastor
453-5252 453-1099

EARLY SERVICE 8:30 A.M.
Sun. Sch. & Bible Classes 9:45 to 10:45 A.M.
LATE SERVICE 11:00 A.M.

HOSANNA TABOR LUTHERAN CHURCH
9600 Levee • So. Redford
937-2424
Rev. Roy Franchise
Rev. Orlan Kopper

Sunday Worship
8:00 & 11:00 A.M.
Sunday School and Bible Classes 9:30 A.M.
Thursday Evening Service 7:30 P.M.
Christian School Grades K-8
Robert Schultz, Principal
937-2233

ST. MATTHEW LUTHERAN Church & School
5885 Venoy
1 1/2 N. of Ford Rd., Westland
425-0280

Ralph Fischer, Pastor
Charles F. Buckhorn, Asst. Pastor
Online Worship 8 & 11 a.m.
Bible Class & SS 9:30 a.m.
Monday Evening Service 7:30 p.m.

Church events are scheduled in Redford

CHURCH OF THE SAVIOR, 38100 Five Mile, Livonia, will have speaking at the annual Men's and Boys' Dinner Judge Keith Leenhouts, director of the VIP division of the National Council on Crime and Delinquency. The event will take place at 6:30 p.m. Wednesday, March 18.

While serving as a Royal Oak judge, Leenhouts developed a probation method that won him national attention. He has authored three Reader's Digest articles and two books and given more than 1,000 talks to civic, church and professional organizations.

Those wishing to attend the program only are invited to do so. The talk starts at 7:30 p.m.

PLYMOUTH CHURCH OF THE NAZARENE, 41550 E. Ann Arbor Trail, Plymouth, will hold revival services through Saturday, March 15 featuring the Rev. Gary Bond, a full-time gospel singer and evangelist in the Church of the Nazarene. Services are at 7:30 p.m. each night.

Bond will be accompanied by his wife, Lisbeth, on the piano.

PILGRIM'S MISSION CHURCH, 5737 Middlebelt, Garden City, has invited to its missionary rally the Rev. Raymond Shreve, who has worked in China before the Communist takeover, as well as Cuba and Central America. He will speak at 7:30 p.m. each evening of the rally which will continue until March 15. He has also worked with thousands of Cubans who recently came to Key West.

GOOD SHEPHERD REFORMED CHURCH, 6500 N. Wayne, Westland, will present a singing group called Higher Power/The Chords at two concerts on Sunday 15. One will be at 11 a.m. as part of the worship service, the other in full concert at 7 p.m. Members of the group are Scott Cole of Wheatland Penna., Tom Fowler of St. Johns, Mich. and Shawn Winters of Lansing.

church bulletin

JUDGE KEITH LEENHOUTS

FIRST UNITED METHODIST CHURCH OF PLYMOUTH, will welcome Dr. Dean Klump as Lenten speaker at 6:30 p.m. Sunday. Dr. Klump was the association minister of this church from 1971-74. He is vice-president of the executive committee of the Ann Arbor District of Missions and Church Extension. He is also a member of the executive committees of the Conference Division of Missions and the Conference Commission on the Laity.

He earned his doctorate at United Theological Seminary in Dayton in 1978.

FIRST UNITED PRESBYTERIAN CHURCH, 701 Church, Plymouth, will hear the Rev. Paul Seto in the second program of its Lenten Forum Wednesday, March 18. A United Presbyterian minister who recently returned from Iran, Rev. Seto will talk on his experiences in that country.

Innovative worship will be led by the Plymouth Salvation Army leaders and instrumentalists. The program will begin with dinner at 6:30 p.m. For dinner reservations call the church at 453-6464.

LLISBETH and GARY BOND
perform gospel music

PEOPLE'S CHURCH, which meets in Plymouth Canton High school will offer its "Focus on Family" film at 7 p.m. Sunday. The filmed lectures feature Dr. James Dobson, child psychologist. For more information call 981-0499.

FAITH COMMUNITY CHURCH, 46001 Warren, Canton, will offer additional Lenten services on Wednesday March 18 and April 1. For more information call 455-7700.

A fun night for youth, a meeting of the Redford Clergy and a clergy and choir exchange will be among the religious events to take place in Redford in March.

An ecumenical youth fun night will be held from 7 to 9:30 p.m. this Sunday in the gym of St. Agatha Catholic High School, 19800 Beech Daly.

Each senior high youth group is to bring a nine-person volleyball team to play competitively with other youth groups. Each group is also to bring a fun game mix, such as an obstacle course. Cost is \$1.

The Redford Clergy will hold its monthly meeting at Augsburg Lutheran Church, 24801 W. Chicago. Reservations are needed for the noon lunch on Tuesday. The topic will be the International Year of the Disabled.

As part of Redford's Christian Unity Emphasis, Trinity Church of the Brethren and St. Robert Bellarmine Catholic Church will participate in clergy and choir exchanges on March 21 and 22.

The first exchange will take place at 6:30 p.m. March 21 in St. Robert, 27101 W. Chicago. It will be followed on March 22 by a combined program at the 9:30 a.m. Sunday service at Trinity, 27350 W. Chicago at Inkster.

Missionaries will speak

Five missionaries will talk about their work at the missionary convention of the East Michigan District of Wesleyan churches March 13, 14 and 15 in Taylor Wesleyan Church, 26431 Van Born, Taylor.

One of the missionaries, the Rev. Don Karns of Guyana, will be the guest speaker at 11 a.m. Sunday services of the Warrenwoods Wesleyan Church, 6615 Venoy, Westland.

The Rev. Paul Swauger, who has worked in Colombia, will talk at a men's breakfast at 8 a.m. Saturday in

Denny's restaurant, 7725 Wayne Road, Westland.

The other three missionaries who will be appearing at the missionary convention include the Rev. James Vermilya, who will talk on Haiti at 7 p.m. Friday, and Dr. Marilyn Birch and Judy Huffman who will speak on Sierra Leone and West Africa at 7 p.m. Saturday.

A tea for women at 1 p.m. Saturday in Wayne Wesleyan Church, 5225 Venoy, will feature Dr. Birch and Miss Huffman.

moral perspectives

Rev. Robert Schaden

We could learn from cults' methods

When the rebellion and the needs of youth are coupled with the systematic recruitment procedures of many cultic groups, the results are often predictable — membership in the cultic beliefs and lifestyle increases.

Rabbi A. James Rudin and his wife Marcia, who have recently published "Prison or Paradise? The New Religious Cults," estimate there are 3 million past and present cult members in this country.

It has not been that long since parents and traditional religion were wondering how to involve young people in faith-centered concerns. And now the same folks are asking what the drawing card is in this religious phenomenon. One might argue that the phenomenon is not as religious as it is psychological.

In a telephone interview, Rabbi Rudin suggested that some of the ingredients include the age-old rebellion of youth, a degree of ignorance, and a need for identity, friendship and community. He also suggested that the systematic recruitment tactics of many cultic groups play directly into these needs.

WE MIGHT ATTEMPT to dissuade youthful adherents with logical arguments. We may even try to frighten them with stories of the Jonestown trag-

edy. However, logic is not the basis of their attraction.

Young people need to feel important. They need to feel wanted, and they need a sense of direction. In their extreme, they would even like someone else to make their decisions. Perhaps the cults are more aware of this than is traditional religion.

The cultic recruiters seem to fill the bill on a variety of counts. For one, they offer a sense of importance — the prospective convert is made to feel important from the first contact.

One young person who was recently recruited told me that he never felt so much like he belonged. I wonder how many young adults have that kind of feeling about their churches and synagogues. Running a young adult program and inviting young adults to be an essential and on-going part of a faith community are not necessarily the same thing.

WE MAY scream that young people do not come flocking to our churches and our synagogues. But reaching out and touching them where they are may prove to be far more effective.

The cults do not grow by putting advertisements in the yellow pages and then waiting for young people to show up at their programs. Somehow, the

yellow pages approach does not create the same sense of importance that comes with a personal approach coupled with on-going contact.

A community of believers who have little more than a catechism or Sunday school understanding of the faith they profess do not have much to offer in this regard.

I find most young adults embarrassed when asked questions about their faith. They are able to label it, but are very inept at explaining it. Perhaps we who are called to be the explainers had better do some homework on what to give and how to give it.

THE APPEAL to a sense of direction is another area at which we might take a harder look. Granted, young people need to make their own decisions and their own faith commitments.

However, we who claim to have a viable faith might well make a more serious effort to give them a basis for making those decisions.

It is always easier to criticize those who march to the tune of a different drummer than it is to consider beating our own drums in a different fashion.

upcoming things to do

WESTLAND CENTER is sponsoring an art show Wednesday through March 22. Marian Betts, a local art promoter, is coordinating the show and has gathered together artists from Westland, Wayne, Plymouth, Farmington, Canton, Dearborn and other areas close to Westland. Among those exhibiting will be Sandra Weed, Westland artist and art instructor, and many of her students.

BOB CICHINI, son of Paul and Yvonne Cichini of Redford, is

appearing in "The Miracle Worker," William Gibson's successful drama about Helen Keller's early childhood, at 8:30 p.m. Friday-Saturday and 2 p.m. Sunday at the Bonstelle Theatre. Tickets for "The Miracle Worker" are available from the Wayne State University Theatre Box Office in Detroit, phone 577-2960.

KARRELL FOX does an impersonation of W.C. Fields in the next Performing Arts Showcase at 5:30 p.m. Sunday at the Livonia City Hall Auditorium. Tickets for the one-man show are \$2.50. Fox, who is from Farmington, is 43 years old and has spent 28 of those years in show business. The showcase is sponsored by the Livonia Arts Commission.

Altman's 'Health' at Detroit Film Theatre

Director Robert Altman's 1980 film "Health," completed just before his recent "Popeye," will be shown by Detroit Film Theatre at 7 and 9:30 p.m. Friday at the Detroit Institute of Arts auditorium.

Tickets at \$2 each may be purchased in advance through the art institute ticket office and at the door. DFT also offers a 10-admission discount coupon book for \$15 — good for any DFT weekend movie evening.

Using a gathering of health food addicts as a metaphor for the American political process, the film features Lauren Bacall, Carol Burnett, James Garner and Dick Cavett.

"Scandal," the 1950 film completed by famous Japanese director Akira Kurosawa just before his classic "Rashomon," and long unavailable in the United States, will be shown at 7 and 9:30

p.m. Saturday. The film examines the responsibility and irresponsibility of the press and what the director himself terms "the confusion of freedom with license," and stars Toshiro Mifune and Takashi Shimura.

Rita Hayworth plays the title role in "Miss Sadie Thompson," a 1933 film set for the 3-D series at 7 and 9 p.m. Sunday. This story of a "bad girl" confronted by a fire and brimstone preacher (Jose Ferrer) represents a film industry attempt at the "adult" use of the 3-D process.

Intended for adults, Detroit Film Theatre presentations may not be suitable for all family members. Adult discretion is advised. Patrons are directed to consult the DFT schedule for guidance. For a free schedule call the art institute ticket office at 832-2730.

HAWAIIAN LUAU

Sunday March 29
LOFY'S TOO
8701 Inkster Road
Westland, MI
"Elvis" Gibson Revue
TICKETS NOW ON SALE
261-5656



CHOMP! CHOMP!

We're getting closer! Only a few more days 'til the taste that made the South love chicken comes to

32788 Cherry Hill (Corner of Venoy)
Garden City 427-0880

Famous Recipe
FRIED CHICKEN

The taste that made the South love chicken at prices chicken-lovers love.

CONCERT OF SACRED MUSIC

DAVID BAKER
Nationally Known
Baritone

GALLIMORE SCHOOL
8375 Sheldon Road
Sunday Morning, March 15
11:00-12:00 a.m.

Sponsored by Canton Free Methodist Church
FREE ADMISSION
For information call 453-7366, Saturday
PUBLIC WELCOME

BIFF'S FAMILY RESTAURANT

FISH & CHIPS..... \$2.99
ALL YOU CAN EAT
Fri.-Sat. 3-10 p.m.

2 SAUSAGES or BACON
2 EGGS
ALL THE PANCAKES
YOU CAN EAT..... **\$1.95**
Sat. & Sun. All Day

36-80 Plymouth Rd. (At Levan) Livonia 591-9555

STREET'S PUB

HAPPY HOUR 4-7 p.m.

- SOUP
- SANDWICHES
- SALAD BAR
- COCKTAILS

LOCATED IN THE REAR OF THE PALACE RESTAURANT
FORD ROAD AT I-275

CYPRUS GARDENS FAMILY RESTAURANT
Greek and American Food

Celebrate St. Patrick's Day With Us!

BEER • WINE • COCKTAILS
FISH FRY EVERY FRIDAY
ALL YOU CAN EAT! \$3.25

- Breakfast Specials
- Businessman Lunches

BANQUET FACILITIES WITH SEATING UP TO 150 PEOPLE

5830 Sheldon Rd. at Ford
Harvard Square • Canton

Mon-Sat 8 a.m. - 11 p.m. 455-7220
Sun 8 a.m. - 9 p.m. 455-7222

WE'RE MORE THAN A NICE PLACE TO EAT

Our Thursday Seafood Buffet
is like a visit to a New England fishing port. Let us unlock the pleasures of the briny deep for you. A whole of a salad bar, fresh Shrimp, Rainbow Trout, Fried Clams, Mai Mai, Scallops Oriental, fresh Lemon Sole, and Jumbo King Alaskan Crab Legs to name a few items. Discover Culinary Delights from Davy Jones' Locker soon.

5:00-9:30 Every Thursday

The Hillside Inn
41661 PLYMOUTH ROAD, PLYMOUTH 453-4300

DINING AND ENTERTAINMENT GUIDE

ON THE TOWN

An Irish Delight on St. Patrick's Day

CORNEBEEF & CABBAGE
including Irish Potatoes & Carrots
SUPER DINNER-SUPER PRICE

Sing-A-Long Piano Bar
featuring DICK KING-3:00 PM til ?

Proper Place

25641 Plymouth • Redford (corner of Beech)
All Major Credit Cards Accepted 937-8220

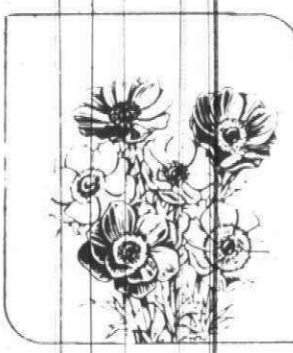

NEW OWNER — MIKE STOYANOVICH

The Sherwood Inn

ELEGANT DINING
• COCKTAILS • LUNCHEONS • DINNERS
• Semi Private & Private
BANQUET ROOMS from 20-125

Now Appearing: **DENNIS ROME & CO.** Tues. thru Sat.
Special March 17: **ST. PATRICK'S DAY**
• Corned Beef & Cabbage
• Irish Stew

Ladies Night Every Wednesday
Happy Hour Mon. & Fri. 4-6 p.m.

3607 1 Plymouth Road
Livonia **261-5500**

Chinese - American Cuisine

- LUNCHEON SPECIALS DAILY
- COCKTAILS
- CANTONESE STYLE
- FAMILY DINING
- BANQUET ROOMS
- CATERING SERVICE

Carry out 326-1310

CHINA STAR PALACE

270 S. Wayne Rd. • Westland
Just south of Cherry Hill

ST. PATRICK'S DAY PARTY
Tuesday, March 17
Noon - 10 p.m.

- Green Beer

St. Patty's Lunch Special
Corned Beef & Cabbage
\$1.98

"Thomas Blood Band"
9:30 p.m. - 2 a.m.
for your listening and dancing pleasure

ANTHONY & CO.
27554 W. Warren — Westland
(1 Block West of Inkster) **261-7130**

40 Different Kinds of Omelettes

Silverman's
HOME MADE Specialties

Featuring 40 Types of OMELETTES (3 Eggs)
All individually done for you with choice of Bagels, Biscuits or Toast
American Fries or Hash Browns
"More than you can eat"

1/4 lb. **BURGERS**
25 Types
All on Onion Rolls
— All Natural Cheeses —

Fantastic **DELI SANDWICHES**
Served Kosher Style (Oy vay)

10 **Dinner Entrees**

And...
As Always Our **DAILY SPECIALS**

Monday & Tuesday
Spicy Pesto or Sweet and Sour Cabbage Soup
Choice of 1/2 Pocket Sandwich **\$2.50**

Wednesday
SPAGHETTI DINNER
All You Can Eat **\$2.95** (Mama Mia)

Thursday
LIVER & ONIONS
DINNER (Soup of Day Cream of Broccoli) **\$2.95**

Friday
FISH N' CHIPS
All you Can Eat **\$2.95** (Crab, all day, What's Inside, In-White)

Saturday & Sunday
FRIED CHICKEN DINNER
All You Can Eat **\$3.50**

"Something Different for Michiganians in the Westland area."
34410 Ford Rd.
Westland
(Across from Coliseum Racquet Club)

Farwell & Friends
8051 Middlefield
Bet. Joy Rd. and Ann Arbor Trail
Call 421-6990
Banquet Facilities Available

FARWELL'S FARE OF THE WEEK

TUESDAY WEDNESDAY
Crab Legs Sirloin Strip
\$6.95 \$6.95

THURSDAY FRIDAY
Prime Rib Fish & Chips
\$7.95 \$3.95

Now Appearing Wed.-Sun.
"LOST and FOUND"

Celebrate St. Patrick's Day with us!!!
Serving Mulligan Stew, Green Beer, Lots of Irish Music, Smiles and Good Times!

OPEN MON-FRI. 3 P.M.-2 A.M.
SATURDAY - NOON-2 A.M.

Hawkeye Lounge

The Tastiest

- Bar-B-Que Ribs — 1/2 slab \$3.95
- Bar-B-Que Chicken — 1/2 Chicken \$3.50
- Fish N' Chips..... \$3.00
- Crab Legs — Dinner..... \$5.95

EAT IN OR OUT
Serving 3 p.m. — Midnight
Mon. - Thurs.
3 p.m. - 2 a.m. Fri. & Sat.

COCKTAIL HOUR
Mon.-Sat. 3 p.m. - 8 p.m.
Reduced Prices Beer, Wine & Hi Balls

LARGE SCREEN TV
ALL SPORTS and MOVIES

7020 WAYNE RD. S. OF WARREN WESTLAND 728-7440

NEWLY REMODELED

The Chalet of Livonia

Now Open on Sundays at 2 p.m.

CHILDREN'S DELIGHT
Hamburger, French Fries and Coke
75¢

COMPLETELY NEW MENU!

FREE DESSERT with Every Meal

Most BOUNTIFUL SALAD BAR in Town

Late Evening Specials
Served Anytime
Super Sandwiches, Steaks, and Salad Bar

Super Dinner Specials
Served Mon. thru Sun.
COMPLETE DINNER WITH DESSERT \$6.50

Banquet Facilities to 60 Persons

39305 PLYMOUTH RD., Corner of Eckles Rd.
464-2272

backgammon
Michael Klolan
 of the American Backgammon Club

THE POWERLESS DOUBLING CUBE Open backgammon tournament. Having reached the finals and a score of 12-11 in a 13-point match, I arrived at this

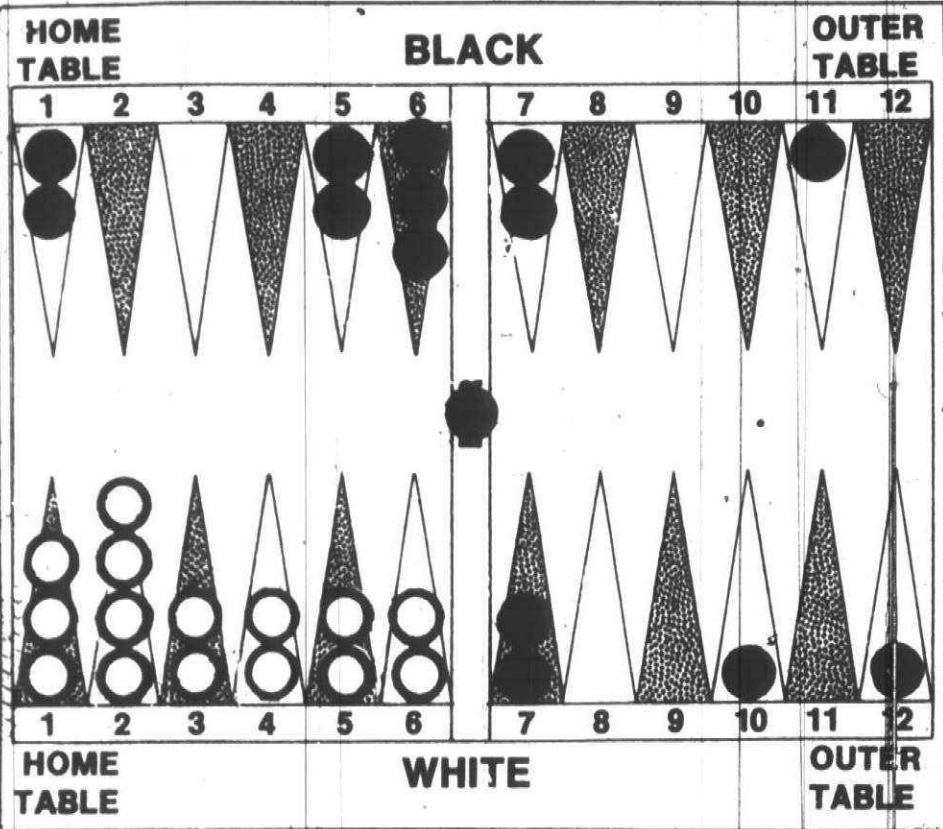

position playing white. With one point needed to win the match, the Crawford Rule applied, preventing either player from using the cube for this game only. Once the cube loses its power, it is important that each move be executed with caution. With the cube in play in this position, I could have easily forced my opponent out of the game. White rolls a 5-1. What is your suggested move? I moved a checker off the 5 point and moved up to the 4 point, leaving the 5 point open — in almost every position a correct play. Having moved too fast, however, I did not contemplate the repercussions should my opponent remain on the bar and should I roll a 5-1, 6-1, 6-6; 5-5 or 4-4 (seven out of 36 possibilities). Needless to say, he stayed on the bar and I rolled double fives, leaving a checker exposed on the 4 point. Naturally, he rolled a four and continued to roll perfectly until the game was won. Having lost the game and the match, I placed second. Analyzing this position, there was a definite error. Moving a checker to the 1 and 5 point from the 6 point would have been best for one reason. By leaving the 6 point open, you allow black to escape behind you, thus getting him out of your hair. If black does not roll a six, white would be hard-pressed to roll perfectly to avoid leaving a shot. Since black had only one checker on the bar, this would have been a wise play. With two checkers on the bar, the first move would then have been proper. Also, it is important to note that while moving to the 5 and 1 point gives white several more bad rolls — 6-6, 5-5, 4-4, 6-3, 5-3, 6-5, 5-4, 6-4, or 13 out of 36 rather than 7 out of 36 combinations — it is theoretically correct with one checker on the bar. For more information, contact the American Backgammon Club at 459-5776 or write to Box 599, Plymouth 48170.

Festival

The annual Yeats Festival at the University of Michigan will be held Monday and Wednesday through March 21. Four works by the Irish playwright have been chosen for this year's tribute. For ticket information call 764-4311 in Ann Arbor.

MID-MICHIGAN CAT FANCIERS
30th CHAMPIONSHIP
CAT SHOW
 MOTLEY
 HOURS: Saturday 10-5 Sunday 10-4
 1977 UNITED FEATURE SYNDICATE INC.
 MARCH 14-15, 1981
 SOUTHFIELD CIVIC CENTER



Gyorgy SANDOR
 PIANIST
 Bartok Centennial Pianist
 Tuesday, March 17, 8:00 P.M.
Orchestra Hall
 Box Office Open 11-6 Mon. thru Sat.
 833-3700
 3711 WOODWARD • ALL SEATS RESERVED

PASTA FEAST
 All Pasta Dinners include antipasta, salad \$5.95 complete
SPECIAL VEAL DINNERS FOR TWO
 includes 1/2 liter of wine \$17 per couple
The Roman Terrace
 Fine Dining at yesterdays prices
 27822 Orchard Lk Rd at 12 Mile
 Private Rooms Also Available Mon-Sat FOR INFORMATION 851-4094

HURLEY'S
PRESENTS
 Jazz with **WAVELENGTH**
 for your listening and dancing pleasure.
 Monday - Thursday from 8:30 p.m., Friday and Saturday from 9 p.m.
 NORTHFIELD HILTON
 5500 Crooks Rd. at I-75
 Troy, Michigan 48098
 (313) 879-2100

FRIDAY & SATURDAY ONLY!
SEE IT!
 ★ 1980 Drama Desk Award
 ★ 1980 Outer Critics' Circle Award
 ★ 1981 Grammy Award
MARCH 13 & 14
PAT CARROLL
 in her award winning New York triumph
GERTRUDE STEIN
 GERTRUDE STEIN GERTRUDE STEIN
 "One of the ten best theatrical events of the year. I got more than I bargained for. Four star anywhere."
New York Times
 "Hilarious, entertaining, exhilarating among the best solo theatre pieces offered over the last decade."
Variety
 Fri, 8:30 pm, Sat, 2 & 8:30 pm • Tickets \$4.50 to \$12.50
ORDER BY PHONE CALL 963-7680
 VISA or MC • CTC Outlets • Groups call 963-7622.
MUSIC HALL CENTER
 350 Madison Avenue at Brush, Detroit

Direct From **LAS VEGAS** and The Johnny Carson Show
Axle's
 Axles also offers exquisite steaks, chops & seafoods.
 Have your meals expertly prepared by our Chefs at your table (by request)
Super Happy Hour!
 Mon.-Fri. 3 P.M.-7 P.M.
 2 for 1
 Continuous Entertainment from Noon til 2 A.M.
 Businessmens Lunches during the week.
 Professional Catering for your Private Parties and Banquets.
 Ample Valet Parking.
 20401 W. 8 Mile (3 blks. West of Evergreen)
 FOR RESERVATIONS CALL 538-1970

Something is striking with deadly accuracy at our foundations...

A dramatic, penetrating, yet hopeful look, deep inside the pain and tragedy of the American family.

STARRING JOHNNY AND JUNE CASH
 BOB HOPE • RICH LITTLE • DIONNE WARWICK
 ROY CLARK • CHERYL LADD • STEVE ALLEN • B.J. THOMAS
 ANDY GRIFFITH • DENNIS WEAVER • HOWARD K. SMITH
 BILLY GRAHAM • WILLIAM SHATNER • EDDIE ALBERT
 DEBBY BOONE • GEORGE KENNEDY

SATURDAY MARCH 14 8-11p.m. WJBK TV-2

Move Down Your Dial to 95 FM for Detroit's Best Music

wmjc 95fm
 Magic

Many stars to shine at Oakway's Cabaret Concert



Beauty contest winners, lyric soprano Mabel Arvo, Mrs. Michigan (left) and soprano Heidi Hepler, Miss Michigan, will be soloists at the annual Cabaret Concert.

Oakway Symphony Orchestra's annual Cabaret Concert will feature a wide array of performers, as well as libation and snacks, for its audience at 8 p.m. March 21 at Madonna College Activities Building (I-96 and Levan).

The program hosted by Fat Bob Taylor, local media personality, will present lyric soprano Mabel Arvo, Mrs. Michigan; soprano Heidi Hepler, Miss Michigan; and pianist Fontaine Laing, as well as the Oakway Symphony Orchestra under the direction of Francesco Di Blasi and guest conductor Sister Mary Francilene Van De Vyver, president of Madonna College.

Fontaine Laing has a bachelor's and master's in music from the Universities of Texas and Michigan, respectively. She has recorded with Erwin Monroe, a first chair of the Detroit Symphony Orchestra.

A resident of Novi, she has toured extensively in Canada and Germany. Her contribution to the evening's program will be Liszt's Hungarian Fantasia.

BENTLEY HIGH School graduate



Fontaine Laing, pianist, also will be a soloist.

and Livonia resident Heidi Hepler, current title holder of Miss Michigan, is a

Actress plays dinner theater

Actress/singer Beth Fieger of Southfield is currently appearing in two shows for Theatre of the Arts, TAP, Ltd.

The dinner theater organization presents Ms. Fieger in "Hayfever," the Noel Coward comedy Friday-Saturday

evenings at the Book Cadillac Hotel in Detroit, and as part of the quartet in the musical revue "Oscar" Sunday evenings at Roberto's in Berkley.

Reservations for Theatre of the Arts productions can be made by calling 288-0450.



Adams Towne House
 30843 PLYMOUTH RD.
 2 BLKS. E. OF MERRIMAN
 421-5060

SUNDAYS OPEN 12-12

DINING & DANCING LENNY SCHICK
 Wednesday thru Sunday

Our Famous Buffet served Wednesday & Thursday 5:00-9:00 P.M. All You Can Eat \$4.95

Corsis Banquet Halls
 and Family Restaurant

Completely remodeled
 Seating 350 people

We cater to all occasions
 Weddings, Sports Banquets
 serving your favorite beer, wine & cocktails

27910 W. 7 MILE
 LIVONIA
 Between Middlebelt & Inkster
 Phone: 531-4960
 After 11 A.M.

WING YEE'S
 CANTONESE AND AMERICAN CUISINE

- CARRY OUT SERVICE
- BANQUET ROOM AVAILABLE
- COCKTAILS • FAMILY DINNERS

Try Our **COMBINATION LUNCHEON SPECIAL**
 Monday-Saturday, 11 a.m. - 4 p.m.

37097 6 MILE RD., LIVONIA
 NEWBURGH PLAZA
 591-1901

Open 7 Days
 M-TH 11-11
 F-SAT 11-12
 SUN. 12-10

MOST MAJOR CREDIT CARDS ACCEPTED

16th Anniversary DINNER SPECIAL
 FOOD AT ITS BEST

ANY DINNER \$8.00

CHOICE: Alaskan King Crab Legs, NY Strip Steak, Filet Mignon Steak, Prime Ribs of Beef, Broiled Lamb Chops, Includes: Soup, Salad, Idaho Potato, Bread & Butter

SERVED FROM 4 P.M.

SEAFOOD PLATTER SURF & TURF \$9.95

KING SIZE COCKTAILS
 Thinking of a Party?

Ideal accommodations up to 200 guests.
 Call Beverly Feuder for reservations
WE GOT IT ALL...IT'S ALL RIGHT HERE!

MITCH HOUSEY'S IN LIVONIA
 28500 Schoolcraft - Jeffries X-Way Exit 177 West & #176 East 425-5520

Johnny K's
 Luncheons - Dinners
 Cocktails

Join us for our gala **ST. PATRICK'S DAY PARTY**
 FOOD & ENTERTAINMENT

Open Mon-Fri 11 A.M.-2 A.M.
 Open Saturday 5 P.M.-2 A.M.

32826 W. Five Mile Rd.
 (East of Farmington Rd.)
 Livonia 425-8530

Under New Management
Village Pump
 ALL NEW ENTERTAINMENT

Sandy Haley
 at the piano
 Wed.-Sat. evenings
 House Fish & Chips & Delicious B-B-Q Daily

Sherrie's Jubilee Attitude
 Adjustment Hour
 4:30-6:30 P.M. Discount Prices

32350 W. 8 Mile Rd.
 1/2 Mile West of Farmington Rd.

student of voice coach Margorie Gordon and has studied at Interlochen and Wayne State. She has sung with University of Michigan's Opera Theater and Detroit's Piccolo Opera.

Lyric soprano Mabel Arvo is the current Mrs. Michigan and the first grandmother to receive this award. She is a Novi resident. Mrs. Arvo, aside from her music accomplishments, is a student at Oakland Community College, Orchard Ridge Campus.

Bob Taylor, a Whitmore Lake resident, is currently with WAAM radio in Ann Arbor. A frequent concert performer, he is a winner of the Grinnell Vocal Composition and has been offered a contract with the Metropolitan Opera.

Aside from his duties as master of ceremonies, Taylor will participate in duets with Mrs. Arvo and Miss Hepler and direct the audience in a sing along of selections from the '20s.

Bar service and snacks will be available to the audience from 7-11 p.m. Admission is \$6 per person, with discounts for advance service of full tables with a table of eight going for \$40 and a table of 10 for \$50.

Tickets are available at the door. Tickets also may be purchased at Hammell Music, Madonna College and Southfield Parks and Recreation.

ferred a contract with the Metropolitan Opera.

Aside from his duties as master of ceremonies, Taylor will participate in duets with Mrs. Arvo and Miss Hepler and direct the audience in a sing along of selections from the '20s.

Bar service and snacks will be available to the audience from 7-11 p.m. Admission is \$6 per person, with discounts for advance service of full tables with a table of eight going for \$40 and a table of 10 for \$50.

Tickets are available at the door. Tickets also may be purchased at Hammell Music, Madonna College and Southfield Parks and Recreation.

Topinkas
 NOW APPEARING at the "Country House" Recording Artists
Carl & Brenda Vanover & Shenandoah
 Tues. thru Sat. Evenings
 for your listening & dancing pleasure

Also June Lowe Astrologer Wed. Evenings

...Always the finest in
LUNCHEONS • DINNER • COCKTAILS
 featuring our famous
Appetizer Buffet at both locations
 Served at Lunch and Dinner

This Sunday bring the entire family for delicious, good old fashioned...
Family Style Chicken Dinner \$6.95
 All You Can Eat Country House Farm Fried Chicken
 Tender Spring Chicken, Served Family Style \$4.95 per person Children 10 & Under

Join Us at our sumptuous Sunday **Family Brunch \$5.95**
 10 a.m. to 2 p.m.
 Children under 10 \$4.50

Chef's Dinner
 Features Served Daily

U.S.D.A. Choice top Sirloin Steak \$6.95
 Broiled Fresh Boston Scrod \$6.95
 Dinner includes Salad, choice of Potato

Businessman's Luncheons Served Daily

Serving Luncheons Monday thru Saturday Dinners 7 Days

We cater to all parties and banquets
 Call for Information and Reservations

TOPINKA'S COUNTRY HOUSE 24010 W. 7 MILE 531-9000
 Serving Luncheons & Dinners Open 7 Days

TOPINKA'S ON THE BLVD. 2960 W. GRAND BLVD. 875-2614
 Serving Luncheons & Dinners Open Mon. thru Sat.

SMILE
 Tomorrow is Friday

NEW APPEARANCE of the SHOW CASEMAN BAND

HAPPY ST. PATRICKS DAY from the **OAK BARREL SUPPER CLUB**
 Celebrate all day and all night with our special Irish food, Cocktails & Noisemakers All in Green

Reservations Call: 535-0633 535-6090

it's... a whole new country

JR's PLACE

WEST DETROIT SUBURB'S NEWEST, MOST EXCITING AUTHENTIC COUNTRY WESTERN LOUNGE

Texas Happy Hour Daily until 8:00 p.m.
 Wed. Thurs. Sat. 7:00-8:00 p.m. • Fri. 3:00-8:00 p.m.

Texas Happy Hour Means:
 No Cover Charge
 Low, low pitcher beer prices
 \$1.00 all drinks - \$1.00 Bull Ride
 \$1.00 Nachos - Pizza 1/2 OFF

JOIN THE FUN EARLY AND SAVE. SAVE. SAVE!!!

FREE ADMISSION - With this coupon only.
 Admit any two adults 21 years or older Free any night!!

JR's Place
 33201 Plymouth Rd. at Farmington Rd. - Livonia Sheldon Shopping Center 313/421-5460

Coupon Expires 3-21-81

NOW OPEN
 Wednesday 7 p.m. - 2 a.m. (Pitcher beer night)
 Thursday 7 p.m. - 2 a.m. (Ladies Night)
 Friday 2 p.m. - 2 a.m. (3 p.m. Texas Happy Hour)
 Saturday 7 p.m. - 2 a.m.

IT'S... A WHOLE NEW COUNTRY!

it vs. ON

More Movies
 More Hours Per Day
 More Matinees
 More Total Programming Time

Comparison based on ON-TV's March 1981 Entertainment Guide

Check it out.

Call today: 313-973-7731 or toll-free 1-800-482-3380

Operators standing by 7:30 a.m. - 10:00 p.m. 7 days a week
 Available in most metropolitan Detroit areas

Subscription TV

Prep swimmers ready for state finals

A host of area swimmers will hit the water this weekend vying for places in the prep state championships.

The Class A meet will start with the preliminary heats at 3 p.m. Friday at the University of Michigan's Matt Mann Pool in Ann Arbor. Final races begin at 3 p.m. Saturday. The Class B meet will run simultaneously at Grand Rapids Junior College.

Detroit Catholic Central has won qualifying berths in both relays and 14 individual spots.

The Shamrocks' 400-yard freestyle relay team of Frank Sugrue, Brian Hurley, John Cullen and Pete Klebba qualified with a time of 3:19.1.

Klebba and Kurt Bonatz have earned spots in two freestyle events each.

"I hope to finish in the top 10," said CC coach Deloris Yager. "If they do, I'll be so happy."

CC won the Catholic League championships last weekend. Many of the Shamrocks posted their best times of the season.

"It's time they moved," said Yager. "I don't come here at five in the morning to lose."

CC's best finish during the past 14 years in Class A has been sixth.

Yager predicts Bloomfield Hills Andover, Birmingham Seaholm, Ann Arbor Pioneer and Warren are the teams to beat.

Plymouth Salem will also send two relay teams to the meet. The 400 freestyle team of Tim Harwood, John Thompson, Doug Kleinsmith and Russ Shaffer finished second last week in the Suburban Eight League meet.

Bruce Harwood, second in the 100 backstroke at the league meet, has also qualified. He will be joined by teammates Gary Workman, Paul Perkowski and Jeff Kleinsmith in the 200 medley relay.

LIVONIA BENTLEY'S Paul Dudley, a seven-time Suburban Eight League champ, was scheduled for minor surgery yesterday and probably will not compete. The Bulldog standout, however, qualified in all three freestyle events. Teammate Brett Lemon has qualified for the 50 freestyle.

Livonia Stevenson will send only one swimmer, Pat Schoff, who qualified for the 100 backstroke.

Livonia Franklin's Brad George (100 butterfly) and John Herfkens (100 back-

stroke) will make the trip to Ann Arbor. Northwest Suburban League foe Westland John Glenn is sending junior Greg Dawkins (100 and 200 freestyles) and Jerry McGue (50 and 100 freestyles).

Glenn's freestyle relay squad of Dawkins, McGue, Doug White and Jeff Dzubek will also compete.

Another Northwest Suburban League team, Redford Union, has qualified swimmers John Miloch and Jon Morgan. In the Class B meet, Garden City West appears to be a threat to win some points.

The Tigers have qualified for seven individual preliminary berths.

Mark Devore and Pat Ross have qualified for two events each. They will be joined by teammates Marty Micek (500 freestyle) and Joe Trigg (100 breaststroke).

Devore, Ross, Trigg and Dave Burgos will swim in the 400 freestyle relay.

Livonia Clarenceville's lone representative will be Paul Larson in the 200 individual medley.



Livonia wins Midget puck crown

Almost 2,000 fans passed through the gates last weekend at the Plymouth Cultural Center for the Michigan Amateur Hockey Association (MAHA) Midget state finals.

A large turnout watched Livonia beat Fraser, 3-2, in overtime, for the championship Sunday afternoon for 15- and 16-year-olds.

Host Plymouth put a good show on for area fans by finishing fourth in the eight-team event.

Plymouth, coached by Bob Hodge, was ousted in the semifinals by Fraser, 10-2. Tom Smith and Sam Barrie scored for the losers.

In the division opener Thursday night, Plymouth defeated Lincoln Park 8-5, as Rich Bahlow and Larry

Figuiski tallied two goals each.

In a Saturday morning encounter, Lakeland defeated Plymouth, 4-2, as Barrie and Mark Hollowood scored the lone goals.

Plymouth rebounded and gained second place in its four-team division with a thrilling come-from-behind triumph over Jackson.

The hosts advanced to the final four on a tie-breaker rule over Lakeland. Both teams had 2-1 records.

The winners trailed early, 4-1, but roared back and eventually won on Hollowood's goal with 4:12 left in the third period. He scored two goals as did Figuiski. Brian Hodge and John Sule tallied other goals.

Plymouth, which sported a mediocre

11-12-1 record in the Adray Community League, earned a berth in the state finals because it was hosting the tournament.

"ANYTIME YOU advance to the semis," said Hodge, "it's a plus."

"Realistically we knew we were in deep."

"Jackson was a district winner. I was happy were were able to beat them. This is quite an improved team. We were 1-8 to start the season."

"And at the end of the year we played these teams a little tougher." Livonia won the title when Marty Hussey scored with 3:12 to go in the first overtime period.

Earlier in the tournament, Fraser

had beaten the Livonians, 4-1.

The Cultural Center will host another state tournament this weekend.

Eight Bantam (13-14) clubs from across the state will vie for honors. Plymouth will face Grosse Pointe in the opener at 6:30 p.m. tonight.

Play will continue through Sunday. The championship game is slated for 6 p.m.

Tickets for adults are \$2 per session and \$8 for the entire tournament (15 games). Students (8-18) can purchase tickets for \$1 per session and \$4 for the tournament.

Pat Dugan will coach the Plymouth entry. Other teams competing include Dearborn, Taylor, Flint, Farmington, Ann Arbor and Livingston.

District doldrums: Canton, Salem lose

Plymouth Canton and Plymouth Salem failed to advance out of the Class A district tournament last weekend at Ann Arbor Huron.

Temperance-Bedford won the title with a 6-15, 15-12, 15-13 triumph over Huron in the final. The Stubborn Mules will now play in the regional Saturday at Lansing Waverly.

Salem was eliminated in the first round by tourney favorite Huron, 15-13, 15-9.

Meanwhile, Canton won its opener against Ann Arbor Pioneer, 15-10, 15-5. The Chiefs were then ousted by Temperance, 15-4, 7-15, 15-9.

"Huron was really good on offense, but Bedford was much more of a well-rounded team," said Canton coach Cyndi Burnstein, whose team bowed out with a 9-6 dual meet record.

The Chiefs started slowly in their encounter against Bedford.

"It was mistake after mistake in the first game," Burnstein said. "In the second game, we played well."

Debbie Dickinson had numerous spikes against Bedford in the middle game to pull Canton even.

"In the third game we didn't play badly," said the Canton coach. "We just made more mistakes. They weren't mental, but they just played steadier than we did."

Burnstein praised the play of senior Marianne Pink and sophomore reserve Ranae Edwards. Edwards "played really great in the back row."

"She made some incredible saves," said Burnstein.

Canton also was plagued by poor service.

"We had a lot of problems," said the Canton coach. "We had five bad serves in the second game. We don't usually do that."

U-M grid coach airs enthusiasm

You hear only the horror stories about college coaches recruiting high school athletes.

It usually crops up when somebody gets caught with their hand in the cookie jar. The allegations and punishments handed down by the NCAA against four PAC-10 football schools come most recent to mind.

Recruiting, however, is downright enjoyable and a challenge to University of Michigan's Bob Thornbladh, an assistant coach.

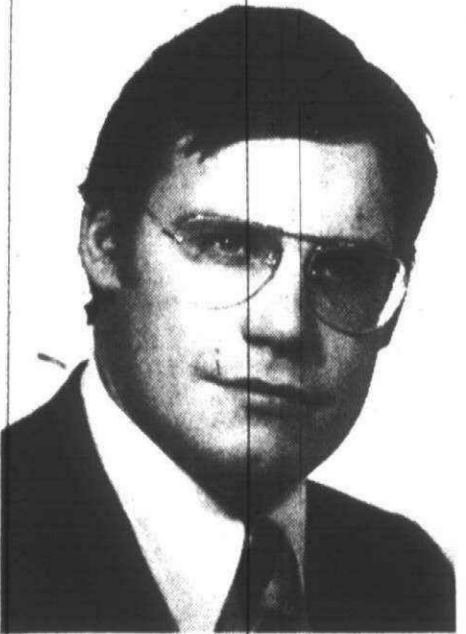

BOB THORNBLADH Likes recruiting



Brad Emons

The former Plymouth High School star, who later played a year for the Kansas City Chiefs, packs his bags frequently and travels by plane around the country, seeking talented football players and good students.

"I like to meet different people," he said. "The kids are refreshing and they're all different."

"I don't mind the challenge. I feel strongly about Michigan and Bo (Schembechler)."

Thornbladh's primary responsibility is to coach the receivers on the Michigan team, guys like Anthony Carter.

But he also spends a great deal of his time in airports, high schools and the homes of prospective student-athletes. He is in charge of recruiting players from the Chicago area, northern Indiana and New England (mainly New Jersey).

Most of his recruiting efforts for this season are over. Athletes were first able to sign a letter-of-intent on Feb. 18.

The former Wolverine fullback agrees with the NCAA on recruiting.

"I THINK they have good rules," he said, "although some schools and kids don't always act with integrity and in an honest fashion."

"It's fairly equitable. The kids most vulnerable to illegal things are the disadvantaged."

"I follow the rules religiously. Abuses do exist, but most of the people I recruit against are quality people."

Thornbladh, 28, said football should be a primary consideration, but not foremost.

"You should choose a school if it meets your needs," he said. "When I get a kid, it's got to be mutual satisfaction. I want good students with some character. We want Michigan to be conducive to their achievement and to have some fun."

Recruiting against the likes of Notre Dame, Ohio State and Michigan State, Thornbladh has had some disappointments.

"Sometimes you take it personally when you don't get a kid," he said. "But the competition is keen and you're not going to get everyone."

"To have some say no, it's difficult. It's hard."

What keeps Thornbladh highly enthusiastic is his constant interaction with the athletes, students and the coaching staff at Michigan.

"I like my association with young people," Thornbladh said. "I feel strongly about my product. Bo is the perfect boss. He's stimulating and challenging."

NOW THAT the recruiting season is over, Bo and his staff are preparing for spring practice, which begins next week. NCAA Division I-A schools such as Michigan are allowed five weeks, four practices per week.

"We're breaking down the films and evaluating our football team for spring," said Thornbladh. "We meet every day, talking about new ideas."

The spring season will culminate April 18 with the annual Blue-White scrimmage.

Bob Thornbladh believes the high school student-athlete is protected a lot better today, as opposed to 10 years ago, when he was being recruited.

"Back then they had unlimited visitation," he said. "They allow only six official visits. I was sure of what I wanted to do. I was recruited by some fine schools, but I always wanted to go to Michigan."

"The rules have evolved. Things are better now."

Additional baseball sign-up Saturday

The Plymouth-Canton Junior Baseball League (PCJBL) will hold registration for the 1981 season from 9 a.m. to 3 p.m. Saturday in the Plymouth Canton High School cafeteria.

Additional sign-up will be held March 21.

All boys and girls who will be 7 years old on or before July 31, 1981, and no older than 17 on or before the identical date, are eligible to register.

According to a PCJBL spokesman, facilities are limited. Player placements will be determined on a first-come, first-serve basis.

A NEW GIRLS' softball program is being offered by the PCJBL at Allen School, on Haggerty Road, between Ann Arbor Road and Trail.

The program is available to young-

sters ages 7 through 10, replacing T-Ball.

The new alignment for the girls softball program is as follows: G (Instructional) League, ages 7 through 10, \$14 registration fee; G Junior League, 10-13, \$18; G Senior League, 14-17, \$20.

Registration fees for the boys programs are as follows: C (T-Ball) League, ages 7 through 8, \$14; B League, 9-10, \$18; A League, 11-12, \$18;

F League, 13-14, \$20; E League, 15-17, \$20.

Volunteer managers, coaches and board officers for the PCJBL are needed. Umpires, who will receive compensation for their work, are also wanted.

Those persons interested in volunteer positions should sign up on the registration dates or call Rich Madsen at 420-0223 for more information.

Christian cagers roll at Southfield

Kiser, a 6-2 junior center, grabbed 11 rebounds.

Greg Brown topped Southfield with 12.

Plymouth held a slim 26-25 halftime

lead, but fell behind one point entering the final period.

The lead changed hands 12 times in the second half.

(Continued on Page 2C)

DICK SCOTT
BUICK

PRESENTS
THE PLYMOUTH HIGH SCHOOL BASKETBALL PLAYERS OF THE WEEK JUNIORS

Steve Tuttle
Claude Davis
Al Bhascak
Ron King
Tommie Harris
Matt Thomas
Pat Murphy
PLYMOUTH-CANTON

Dick Scott's Plymouth High School "PLAYERS OF THE WEEK" feature continues this week. Each week one Salem and one Canton player will be saluted for their effort the previous week, with their names engraved on a trophy for display at the high schools. Players will be selected by the coaching staffs of the respective schools. Look for this ad every Thursday. For that "Winning Deal" on a new or used car, see Dick Scott Buick.

A PLYMOUTH HIGH SCHOOL Flashback

In February of 1976, called for just one week in most of the popularity polls as the No. 1 Class A basketball team in Michigan, the Rockets failed to defeat the first team as Detroit's Tigers posted a 93-67 triumph. Southfield, Salem, which now is 10-1 overall, still leads the Suburban 2 in its drive toward a 3rd straight undefeated championship with a 10-1 mark. "They just go on up," admitted coach Fred Thompson of the Rockets, as he credited offering any form of gifts. Southfield announced the packed house by routing to a 13-0 lead in the first 3 minutes and from there on it was all up hill for the Plymouth team. High scorers for Salem were two brothers, all-star forward Tom Edgington, Mike Princess and Brian Wolcott.

BUICK

Dick Scott

200 W. Ann Arbor Rd. 1 Mile W. of I-275
453-4411 Open Mon & Thurs 'til 9 pm

sports shorts

VOLLEYBALL LEAGUE GOES COED
Registration is now being held for a coed volleyball league, sponsored by the Canton Township Parks and Recreation Department.
The five-week league, which begins April 12 at Hulsing School, is limited to six teams.
League play will be held from 7-10 p.m. Thursdays. There will be no playoffs. Trophies will not be awarded.
The registration fee is \$20 per team.
Registrations can be delivered in person or by mail to: Canton Parks and Recreation Department, 1150 S. Canton Center Road, Canton 48188.

Fox Hills Men's Golf League will be held at 10 a.m. Saturday, April 11.
Registration for the 17-week league will begin Monday, March 31. The cost is \$20 per person, which does not include greens fees. Registration can be delivered in person or by mail to: Canton Parks and Recreation Department, 1150 S. Canton Center Road, Canton 48188.
For more information, call 397-1000 between 8:30 a.m. and 5 p.m.

SOFTBALL PLAYERS NEEDED
The Plymouth Jaycees are looking for a few good men.
A slow-pitch softball team is being fielded this summer. The Jaycees need players, ages 18-36.
Those interested should attend the next Plymouth Jaycee general membership meeting at 7:30 p.m. Thursday, March 26, at the Plymouth Cultural Center. For more information, call Tim Sullivan 455-1635.

FELLOWS CREEK MEN TO DISCUSS RULES
An organizational meeting for the Fellows Creek Men's Golf League will be held at 11 a.m. Saturday, April 11, at the Canton Recreation Center, 44237 Michigan Ave. (near Sheldon).
The league, sponsored by the Canton Township Parks and Recreation Department, will run 12-14 weeks beginning in May.
A \$20 registration fee is required (not including greens fees). Registrations by delivered in person or by mail to: Canton Parks and Recreation Department, 1150 S. Canton Center Road, Canton 48188.
League play will be held beginning at 6 p.m. each Tuesday.
For more information, call 397-1000 between 8:30 a.m. and 5 p.m.

FOX HILLS GOLFERS TO HOLD MEETING
An organizational meeting for the

Loss crushes Bentley spikers

Spartans advance in tourney

Livonia Stevenson and Clarenceville are the only two area teams still alive in the state volleyball tournaments.
The Spartans bested an eight-team field last weekend in a Class A District at Schoolcraft College. Clarenceville, participating in the Class B tournament, prevailed at the Novi District.
Both squads advance to regional competition Saturday.
Stevenson will meet Howell 1 p.m. at Howell High School. Wayne, a state finalist last year, and Dearborn are the other two teams in that regional.
Clarenceville, which has now won four district titles in a row, will duel Saline 11 a.m. at Linden High. Saginaw Eisenhower, which defeated the Trojans last year in the Class B final, will also compete at Linden.

However, all was well that ended well for the Spartans.
"Karen Kelley had an outstanding day at the net. In the back court, she played very well," Cagle said. "Amy Lang had a super defensive day and super passing, and I can't deny the performances of Jill Heppner and Lisa Cluett."

Preceding the confrontation against Bentley, Stevenson trounced Southfield, 15-2 and 15-0, and barely slipped past North Farmington, 7-15, 15-5 and 17-15.
Livonia Franklin was eliminated by Farmington at Schoolcraft, 15-11, 13-15 and 15-6, and Livonia Churchill was defeated by Bentley, 16-14 and 15-6.

CLARENCEVILLE will be making its fourth regional appearance in as many years for coach Tom Teeters.

The Trojans won the Metro West Conference championship again this season and posted an overall record of 12-1 in dual matches.

Clarenceville whipped Dearborn Heights Crestwood in the district final, 15-0 and 15-9.
Elina Haiko served 15 consecutive points in the first game.

Teeters also singled out the efforts of Cheryl Ranta, who competed with a knee injury, and Chris Stellberger, who was below par with an ankle injury.

"Cheryl did a real fine job setting, and Chris, a center-blocker, kept them on the defensive with good spikes," Teeters said.

Teeters praised the work of his three other starters — Cindi Pellegrin, setter, and Rene Koch and Lisa Ferguson, defensive players.

The Trojans defeated South Lyon and Farmington Harrison to reach the district final.

NONE OF three Redford schools or Garden City East participating in the Class A District at Dearborn High survived.

Redford Union lost to the host Pioneers in the final, 15-7 and 15-2. However, RU knocked off East, 16-14, 14-16 and 15-10, and Redford Thurston, 15-11 and 15-12, before falling themselves.

Redford Bishop Borgess defeated Dearborn Heights Annapolis, 15-7 and 15-2 in a first-round game before losing to Dearborn in the semifinals, 15-0 and 15-9.

Westland John Glenn was knocked out in the first round of the Class A district at Romulus by Wayne, 15-7 and 15-8. Wayne eventually won the district title by tripping Trenton, 15-5, 6-15 and 15-8.

Brother combo a hit in tourney

(Continued from Page 1C)
In the final minute, Plymouth went into a semi-stall after a Southfield turnover to run out the clock.
"We worked on our combination presses in practice," said Plymouth assistant coach Steve Bauslaugh, "and it forced them into a lot of turnovers."
Plymouth Christian, which graduates its first senior class next year, finished the season with an overall record of 14-4.
In the tournament opener, John Koss

pumped in 21 points and Jim Koss added 12 as Plymouth Christian advanced to the final with a 49-36 triumph over Detroit Bethesda.
THE EAGLES and Bethesda were deadlocked at intermission, 16-16.
In the third quarter, Plymouth outscored its first-round foes 16-8 and pulled away for the victory with a 17-12 outburst in the fourth period.
"We mixed up our presses and it kind of confused them," said Bauslaugh.

HOUSE OF DENTURES
Licensed Dentist
28350 Grand River Farmington Hills
2 1/2 Blocks West of 8 Mile Rd.
FREE Consultation and Exam
• Relines & Repairs Same Day
• Quality, Personalized Service
• Partials
Insurance Accepted For Appointment Call 478-1485

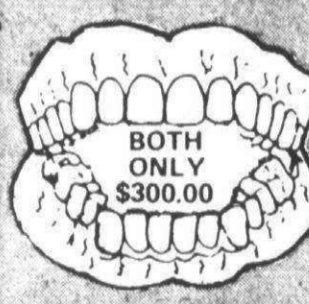

BILL GOODMAN'S GUN & KNIFE SHOW
BUY-SELL-TRADE
THIS SAT. & SUN. OPEN 9-4 PM
YOUTH CENTER
Mich. Ave. at Greenfield Dearborn, MI
Over 250 Exhibits Admission \$1.50
for info call Bill Goodman 755-1215

SALEM LUMBER CENTER
Your Neighbor Shops Here
ANNIVERSARY CELEBRATION!
LOW PRICES ON FAMOUS GLIDDEN INTERIOR LATEX PAINTS
SAVE \$1.49
White or Ceiling White
\$8.99 GALLON
SAVE \$1.49
\$11.99 GALLON REG. \$16.49
White
Colors not included



Put the finishing touch in your home with **Armstrong Ceiling**
The large 2'x4' or 2'x2' panels fit into an easy-to-install metal grid.
See how little the tile in a 10'x12' room costs **\$26.55** 2'x4' (Embossed White)
2x2' No. 943 Textured Fashion Tone—\$56.40
We stock either Black or White Metal Grids

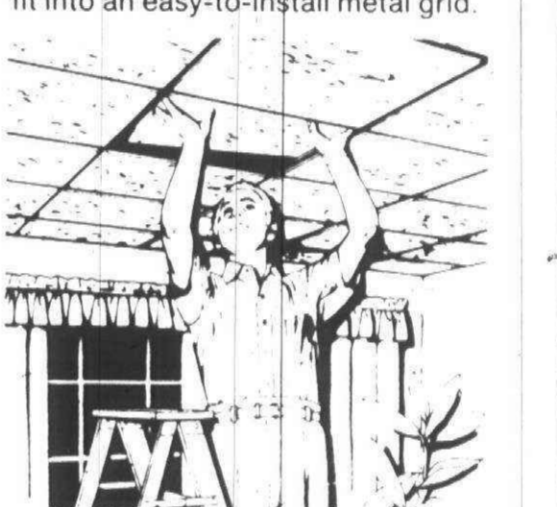

Learn How To Earn with Remvest: Attend a **FREE Money Market SEMINAR**
Topics Include:
• 6 month Money Market Certificates
• Fixed income mortgage rates — under 120 month
• Tax-Free Children's Education Funds
• Tax Shelters — Individual Retirement Account Rollovers
REMVEST PLYMOUTH TROY
Wednesday, March 18 - 7 pm Plymouth Hilton, Terrace Room 14787 Northville Rd. Plymouth, MI 48170
Thursday, March 19 - 7 pm Troy Hilton, Oakland Hill Room 1455 Stephenson Highway Troy, MI
FOR RESERVATIONS OR MORE INFORMATION WRITE or CALL **REMVEST SECURITIES** (313) 425-9000 (313) 476-6670
Refreshments will be served

EARLY SPRING SPECIAL STOCKADE FENCE
6 x 8 Section Pre-Assembled **\$19.88** C & C
#1 Grade heavy 3/4" Pickets
Delivery Available
OR BUILD YOUR OWN
ROUGH ONE SIDE CEDAR FENCE BOARDS
1x4x6 ft. @ \$1.50 ea.
1x6x6 ft. @ \$1.80 ea.
1x8x6 ft. @ \$2.40 ea.
C&C
• Fine 7/8" Thick Stock will make a nice fence with a little effort

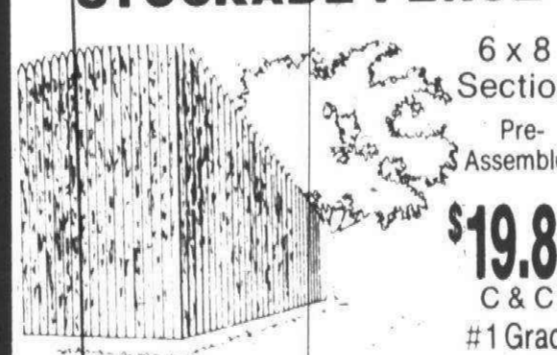

VANITIES BY Beauty Craft
Price include Marble Tops
24" x 19" TOP **\$63.88** 2 Door Model
Choice of Bases
• White/Gold
• Antique Gold
• Pecan
31" x 19" ... **\$73.88** ... Reg. '88.88



NEW ARRIVALS Beauty Craft
OAKWOOD VILLAGER
Vanity 37" x 19" 4 Drawer
cutback right or left
in dark oak or light oak
* Also with natural cane door inserts

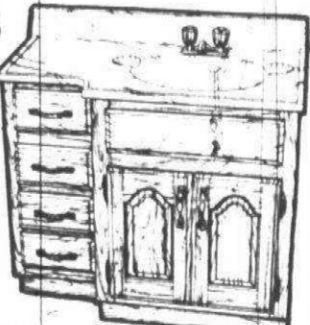

2x4 SOFTWOOD
7 Ft. Studs Our K.D. Economy **79¢**
SELECT YOUR OWN FROM OUR IN-STORE STOCK
We Custom Cut Mon. thru Sat. 9-5:30 PM Sunday 10-4 PM

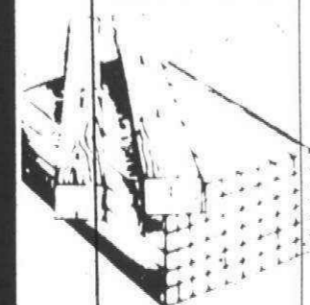

UTILITY PINE BOARDS
6" - 14¢ Lin. Ft.
8" - 25¢ " "
10" - 30¢ " "
12" - 40¢ " "
Dry utility grade, suitable for shelving and general uses from our warehouse bins
6' - 8' - 10' - 12' - 14' - 16' Lengths
You can specify longer lengths

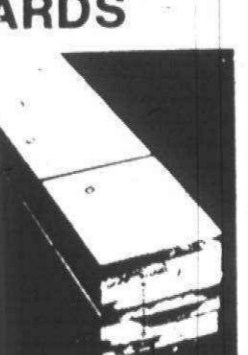

Store Hours Monday thru Friday 9 a.m. - 8 p.m. Saturday 9 a.m. - 6 p.m. Sunday 10 a.m. - 4 p.m.
30650 PLYMOUTH ROAD LIVONIA GA 2-1000
Shed and Mill Hours Monday thru Saturday 9am-5:30pm Sunday 10 a.m. - 4.00 p.m.

A SENTRY FIRE SAFE from **HERALD WHOLESALE** is TAX DEDUCTIBLE PUBLIC WELCOME
If you lose your tax and income records in a fire, and it happens to hundreds of people every day, you could get burned bad when tax-time comes around. Protect these records and other valuables in a Sentry Fire Safe. It's TAX DEDUCTIBLE. Sentry Home/Office safes carry Underwriters Laboratories labels. They've proven their ability to safeguard records against fire and explosion. Has drawer, changeable 3-number combination lock, wheels. Size 24" H x 17 1/2" W x 17 1/2" D. Ideal for home and small business.
other models as low as **\$111.54**
MODEL SHOWN S-3 **\$159.62**
sentry FIRST IN FIRE SAFES
We carry a full line of Builders and Specialty Hardware. Appliances. Cabinets. Windows. Doors. everything for the home.
PHONE 398-4560
HERALD WHOLESALE Inc.
20830 COOLIDGE, OAK PARK 2 DOORS NORTH OF 8 MILE



TROUBLE PUTTING on fitted sheets? Try putting them on diagonally, that is, opposite corners first, the remaining corners will fit with ease. Sell something with ease when you use an Observer & Eccentric Ad.
2 Pair Sale SAVE \$20.00 on this Knapp work shoe. Cushioned Comfort
Sizes to 15. Wide Widths K-48, K-58
Buy One pair SAVE \$8 Reg. \$36.99 Now \$28.99
Buy 2 pair SAVE \$20 TWO PAIR SALE SALE PRICE \$53.98
Made in America **KNAPP** America works in Knapp Shoes. SIZES 5 TO 15, A TO EEEE IN STOCK, SOME WORK AND SAFETY SHOES.
WESTLAND, 7060 Wayne Rd. (diagonally across from Westland Shopping Center) Tel 722-2040. To have a shoe salesman visit you, call any number above. *Over size 12, add \$1.00 Mon., Thurs., Fri., 9:30 to 9:00. Tues., Wed., Sat., 9:30 to 5:30. Sale ends March 11th.



Insurance Help for Small Business Owners
If you are having problems getting insurance, call MICHIGAN OPEN LINE for FREE information and assistance.
MICHIGAN OPEN LINE was formed by insurance companies and local agents to help you protect your business investment.
MICHIGAN OPEN LINE ... insurance help as near as your phone.
MICHIGAN OpenLine
In Detroit: 965-4400 • Statewide: 1-800-482-2218
An Access Program for Commercial Multi-peril Insurance.

swimming

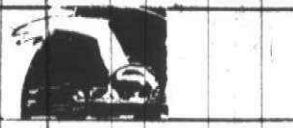

Sports people live others' dreams

Names make news, especially in the world of sports.



By Doug Funke

• Jack McRobert, a Redford resident, is a goal judge at Detroit Red Wing home hockey games.
 • Barry Basel, former boys' track coach at Westland John Glenn, captained the varsity football team at Eastern Michigan University in 1955. The Hurons posted a 7-2 record that season.
 • Fred Price, boys' track coach and former basketball coach at Livonia Churchill, played against the legendary Oscar Robertson in a state championship game while a high school student in Indiana.
 • Joe Kavulich, who referees high school basketball games in the area, also officiates at the collegiate level in the Mid-American Conference.
 • George Van Wagoner, basketball coach at Livonia Stevenson, coached

Gobles to a state Class D basketball championship in 1954 at the age of 25.

Good relations.

• Jerry Kestner, hockey coach at Livonia Stevenson, is the father of Paul, who plays hockey for Livonia Bentley.
 • Kevin Holowicki, who plays basketball for Livonia Bentley, is the son

of Bernie, basketball coach at Detroit Catholic Central.

• Noreen Divens, who coaches the girls' soccer team at Livonia Stevenson, is the mother of Tim, who plays for the boys' soccer team at Stevenson.

• Lisa Lovich, a gymnast for Plymouth Canton, is the daughter of George, athletic director at Livonia Franklin.

• Jack Reardon, football coach at Livonia Stevenson, is the father of Mary, who swims for Plymouth Canton.

• Paul Larson, a swimmer at Clarenceville, is the son of Gordon, swim coach at Clarenceville.

Lost — and found?

• Whatever happened to Rick DREWITZ, who led Garden City West to the semifinals of the state Class A basketball tournament and a 22-1 record during the 1969-70 season?

• What became of Renee ENRIGHT, a Redford Thurston graduate and one of the best all-around athletes ever to compete in the area? She earned all-Observer honors in basketball, volleyball and softball during her high-school career.

• What is Flo Himm doing now? He was a foreign exchange student who played basketball for Livonia Bentley several years ago.

NORTHWEST SUBURBAN LEAGUE BOYS' SWIMMING MEET
TEAM FINISH — 1. North Farmington, 276 points; 2. Livonia Franklin, 223; 3. Redford Union, 186; 4. Westland John Glenn, 175; 5. Redford Thurston, 164; 6. Garden City East, 96.
INDIVIDUAL RESULTS
200-YARD MEDLEY RELAY — 1. Livonia Franklin (John Herkens, Roger Knight, Brad George, Jhn Cassidy), 1:45.6; 2. Redford Thurston, 1:45.3; 3. North Farmington, 1:46.7; 4. Garden City East, 1:50.6; 5. Westland John Glenn, 1:52.6; 6. Redford Union, 1:54.0.
200-YARD FREESTYLE — 1. Greg Dawkins (Glenn), 1:46.6 (league record); 2. Steve Manderfield (North), 1:48.4; 3. Jon Morgan (Redford Union), 1:48.5; 4. Doug White (Glenn), 1:53.8; 5. Carl Guderson (North), 1:56.2; 6. John Pentolino (Redford Union), 1:57.4.
200-YARD INDIVIDUAL MEDLEY — 1. Jon Edwards (Thurston), 2:05.3; 2. Brad George (Franklin), 2:08.4; 3. Roger Knight (Franklin), 2:08.7; 4. Jim Gasser (North), 2:08.8; 5. John Herkens (Franklin), 2:10.6; 6. Ken Stark (Redford Union), 2:11.0.
50-YARD FREESTYLE — 1. Jerry McGue (Glenn), 22.6; 2. Jim Miloch (Redford Union), 23.1; 3. Bob Fortney (Thurston), 23.1; 4. Bill Somerville (North), 24.1; 5. Pete Salazar (Thurston), 24.2; 6. Mike Justice (Franklin), 24.2.
DIVING — 1. Brian Cullen (Glenn), no point total available; 2. Dave Mulliet (East); 3. John

McCann (North); 4. Scott Docherty (Franklin); 5. Andy Trapp (Redford Union); 6. Steve White (North).
100-YARD BUTTERFLY — 1. Jim Miloch (Redford Union), 55.9; 2. Ken Stark (Redford Union), 56.0; 3. Brad George (Franklin), 57.2; 4. John Guderson (North), 58.5; 5. Dan Merritt (Redford Union), 58.6; 6. Paul Gardy (Thurston), 59.4.
100-YARD FREESTYLE — 1. Steve Manderfield (North), 49.9; 2. Bob Fortney (Thurston), 50.0; 3. Jerry McGue (Glenn), 50.4; 4. John Pentolino (Redford Union), 53.1; 5. Lee Trilstch (Franklin), 53.6; 6. Todd LaDouceur (North), 54.5.
500-YARD FREESTYLE — 1. Jon Morgan (Redford Union), 4:55.2 (league record); 2. Greg Dawkins (Glenn), 4:58.8; 3. Carl Guderson (North), 5:13.6; 4. Doug White (Glenn), 5:15.8; 5. Brian Manderfield (North), 5:17.4; 6. Pat Garvey (Franklin), 5:30.2.
100-BACKSTROKE — 1. Jon Edwards (Thurston), 57.0 (league record); 2. John Herkens (Franklin), 58.1; 3. John Cassidy (Franklin), 59.9; 4. Kirk Green (East), 1:02.8; 5. Paul Grady (Thurston), 1:04.1; 6. Glenn Spence (North), 1:05.5.
100-YARD BREASTSTROKE — 1. Jim Gasser (North), 1:04.6; 2. Roger Knight (Franklin), 1:06.0; 3. Dave Willox (Glenn), 1:06.0; 4. Bill Somerville (North), 1:08.4; 5. Robert O'Boyle (North), 1:09.3; 6. Lee Trilstch (Franklin), 1:09.3.
400-YARD FREESTYLE RELAY — 1. Westland John Glenn (Doug White, Jerry McGue, Greg Dawkins, Jeff Dzibek), 3:23.5 (league record); 2. North Farmington, 3:25.9; 3. Redford Union, 3:26.4; 4. Livonia Franklin, 3:43.1; 5. Redford Thurston, 3:44.3; 6. Garden City East, 3:48.5.

TRI-RIVER LEAGUE SWIM CHAMPIONSHIPS Final Results
TEAM STANDINGS — 1. Inkster Cherry Hill, 368 points; 2. Garden City West, 208; 3. Dearborn Heights Riverside, 181; 4. Southgate, 137; 5. Dearborn Heights Crestwood, 118; 6. Southgate, 137; 6. Southgate Schafer, 94.
200-YARD MEDLEY RELAY — 1. Riverside (Craig Mason, Steve Labroff, Tim Folk and Ron Bolz), 1:45.7; 2. Cherry Hill, 1:48.3; 3. GC West, 2:01.9; 4. Southgate, 2:02.3; 5. Schafer, 2:05.0; 6. Crestwood, 2:19.0.
200-YARD FREESTYLE — 1. Mark Devore (GC West), 1:48.2; 2. Martin Powers (Cherry Hill), 1:48.9; 3. John Teschke (Cherry Hill), 1:53.5; 4. Mark Bourdeau (Cherry Hill), 1:57.2; 5. Mark Wohlfel (Cherry Hill), 1:59.5; 6. Marty Micek (GC West), 1:59.6.
200-YARD INDIVIDUAL MEDLEY — 1. Glen Gomoll (Crestwood), 2:11.2; 2. Pat Ross (GC West), 2:11.3; 3. Rick Lee (Southgate), 2:11.3; 4. Kevin Reside (Cherry Hill), 2:11.3; 5. Jeff Pryor (Cherry Hill), 2:16.7; 6. Mark Bahn (Cherry Hill), 2:19.7.
50-YARD FREESTYLE — 1. Ron Bolz (Riverside), 22.8; 2. Kirk Wischow (Southgate), 23.7; 3. Craig Mason (Riverside), 23.9; 4. Mike Teschke (Cherry Hill), 24.1; 5. Jim Koss (Cherry Hill), 24.4; 6. Joe Trigg (GC West), 24.4.
DIVING — 1. Tim Pelfrey (GC West); 2. Sandy Minks (Crestwood); 3. Jeff Hyland (Cherry Hill); 4. Brian Reside (Cherry Hill); 5. Al Trombley (Schafer); 6. Kurt Kormos (Riverside). No scores

available.
100-YARD BUTTERFLY — (Listed times are from preliminaries) 1. Curt McNamara (Cherry Hill), 54.8; 2. Rick Lee (Southgate), 56.9; 3. Mike Teschke (Cherry Hill), 58.2; 4. Ron Wohlfel (Cherry Hill), 1:00.5; 5. Tim Folk (Riverside); 6. Dave Lara (Cherry Hill), 1:05.0.
100-YARD FREESTYLE — 1. Mark Devore (GC West), 49.8; 2. Ron Bolz (Riverside), 50.0; 3. Kirk Wischow (Southgate), 51.7; 4. Jim Koss (Cherry Hill), 52.4; 5. John Mason (Schafer), 54.8; 6. Mark Wohlfel (Cherry Hill), 55.1.
500-YARD FREESTYLE — 1. Martin Powers (Cherry Hill), 4:54.2; 2. Mark Bourdeau (Cherry Hill), 5:10.0; 3. John Teschke (Cherry Hill), 5:10.5; 4. Marty Micek (GC West), 5:13.9; 5. Kim Allen (Schafer), 5:56.9; 6. Joe Bollo (Southgate), 6:01.5.
100-YARD BACKSTROKE — 1. Pat Ross (GC West), 1:01.1; 2. Craig Mason (Riverside), 1:01.3; 3. Glen Gomoll (Crestwood), 1:02.1; 4. Jeff Pryor (Cherry Hill), 1:04.4; 5. Dave Burgess (GC West), 1:04.5; 6. Kurt Wohlfel (Cherry Hill), 1:05.8.
100-YARD BREASTSTROKE — 1. Curt McNamara (Cherry Hill), 1:04.9; 2. Kevin Reside (Cherry Hill), 1:06.2; 3. Steve Labroff (Riverside), 1:06.5; 4. Joe Trigg (GC West), 1:07.4; 5. Tim Folk (Riverside), 1:07.6; 6. Mark Bahn (Cherry Hill), 1:10.2.
400-YARD FREESTYLE RELAY — (Listed times are from preliminaries) 1. Cherry Hill (John Teschke, Mike Teschke, Mark Bourdeau and Martin Powers), 3:27.2; 2. GC West, 3:34.4; 3. Southgate, 3:46.9; 4. Crestwood, 3:50.3; 5. Schafer, 4:00.0; 6. Riverside, 4:03.1.

CATHOLIC LEAGUE SWIM CHAMPIONSHIPS Final Results
TEAM STANDINGS — 1. Detroit Catholic Central, 415 points; 2. Birmingham Brother Rice, 386; 3. Detroit U-D High, 149; 4. Dearborn St. Alphonsus, 50; 5. Detroit DeLaSalle, 33; 6. Harper Woods Notre Dame, 28; 7. Royal Oak Shrine, 2.
200-YARD MEDLEY RELAY — 1. Catholic Central (Mike Schultz, Matt Cashin, Brian Hurley and Mark Mysteravich), 1:42.9; 2. Brother Rice, 1:43.7; 3. U-D, 1:47.7; 4. DeLaSalle, 1:58.9; 5. St. Alphonsus, 2:01.3; Shrine, disqualified.
200-YARD FREESTYLE — 1. Pete Klebba (CC), 1:47.2; 2. Kevin McJoynt (Brother Rice), 1:47.4; 3. Robert Papp (Brother Rice), 1:49.0; 4. Dixon Kane (Brother Rice), 1:51.7; 5. Kurt Bonatz (CC), 1:51.8; 6. Mike Stella (CC), 1:52.5.
200-YARD INDIVIDUAL MEDLEY — 1. Matt Cashin (CC), 2:02.4; 2. Bob Kramer (Brother Rice), 2:03.8; 3. Art Klugo (CC), 2:05.4; 4. Richard Kramer (Brother Rice), 2:06.5; 5. Mike Schultz (CC), 2:07.1; 6. John Pelon (CC), 2:08.4.
50-YARD FREESTYLE — 1. Frank Sugrue (CC), 22.7; 2. Mark Mysteravich (CC), 23.0; 3. Mark Lytle (Brother Rice), 23.1; 4. John Cullen (CC), 22.8; 5. Walter Bernard (U-D), 23.7; 6. Alan Margherio (Brother Rice), 23.5.
DIVING — 1. Ray Peck (Brother Rice), 332.60; 2. Lou Levi (U-D), 305.40; 3. Mike Christopher (Brother Rice), 289.85; 4. Pat Fitzgerald (Brother

Rice), 286.45; 5. John Moore (Brother Rice), 277.00; 6. Ken Messingschlagel (CC), 260.05.
100-YARD BUTTERFLY — 1. Brian Hurley (CC), 55.2; 2. Rob Mackle (Brother Rice), 55.3; 3. Mike Ward (CC), 55.3; 4. Kurt Maczei (Brother Rice), 56.0; 5. Joe Fitzgerald (Brother Rice), 56.7; 6. Mike Sugrue (CC), 57.5.
100-YARD FREESTYLE — 1. Pete Klebba (CC), 49.4; 2. Kevin McJoynt (Brother Rice), 49.7; 3. Frank Sugrue (CC), 49.9; 4. Dixon Kane (Brother Rice), 50.3; 5. John Cullen (CC), 51.2; 6. Mark Mysteravich (CC), 51.4.
500-YARD FREESTYLE — 1. Robert Mackle (Brother Rice), 4:47.2; 2. Richard Kramer (Brother Rice), 4:53.7; 3. Kurt Bonatz (CC), 5:00.6; 4. Tom Hankins (CC), 5:02.0; 5. Kevin Elmiger (Brother Rice), 5:02.1; 6. Paul Schroeder (CC), 5:04.4.
100-YARD BACKSTROKE — 1. Kurt Maczei (Brother Rice), 58.9; 2. Mike Schultz (CC), 1:00.0; 3. John Stanczyk (ND), 1:00.3; 4. Art Klugo (CC), 1:00.7; 5. Robert Papp (Brother Rice), 1:00.8; 6. Matt Ruwart (CC), 1:02.9.
100-YARD BREASTSTROKE — 1. John Ellis (U-D), 1:03.1; 2. Matt Cashin (CC), 1:03.4; 3. Mike Weber (CC), 1:03.6; 4. Rob Kramer (Brother Rice), 1:04.3; 5. Ken Kramer (Brother Rice), 1:06.4; 6. Don Conn (CC), 1:06.7.
400-YARD FREESTYLE RELAY — 1. Brother Rice (Kevin McJoynt, Robert Mackle, Dixon Kane and Richard Kramer), 3:18.3; 2. Catholic Central, 3:19.1; 3. U-D, 3:33.6; 4. Dearborn St. Alphonsus, 3:50.6.

METRO WEST CONFERENCE SWIM CHAMPIONSHIPS Final Results
TEAM STANDINGS — 1. Woodhaven 90 points; 2. Dearborn Heights Annopolis, 76; 3. Clarenceville, 68; 4. Oak Park, 36.
200-YARD MEDLEY REEAY — 1. Annopolis (Bill Casey, Pete Bloye, Randy Danko and Pat Winslow), 1:49.5; 2. Clarenceville, 1:53.2; 3. Woodhaven, 1:57.2; 4. Oak Park, 1:58.3.
200-YARD FREESTYLE — 1. Paul Kurtzhals (Woodhaven), 2:04.1; 2. Rich Truskowski (Woodhaven), 2:05.6; 3. Keith Bo (Woodhaven), 2:05.4; 4. Bill Casey (Annopolis), 2:07.0; 5. Chris McCoy (Woodhaven), 2:09.5; 6. Mark O'Neill (Clarenceville), 2:09.6.
200-YARD INDIVIDUAL MEDLEY — 1. Paul Larson (Clarenceville), 2:13.9; 2. Mark Truskowski (Woodhaven), 2:17.8; 3. Randy Danko (Annopolis), 2:26.0; 4. Dan Dolby (Annopolis), 2:30.3; 5. Pete Bloye (Annopolis), 2:35.8; 6. Mark Perham (Woodhaven), disqualified.
50-YARD FREESTYLE — 1. John Murphy (Woodhaven), 24.3; 2. Pat Winslow (Annopolis), 24.4; 3. Mike Yanko (Oak Park), 25.3; 4. David Yanko (Oak Park), 25.0; 5. (TIE) Jack St. John (Clarenceville), 25.5; and Todd Strachan (Clarenceville), 25.6.
DIVING — 1. Eric Davis (Annopolis), 268.65; 2. Todd Schaefer (Oak Park), 259.90; 3. Todd Strachan (Clarenceville), 243.90; 4. John McManus (Oak Park), 237.60; 5. Todd Blaze (Oak Park), 200.00; 6. George Gillis (Clarenceville), 198.70.
100-YARD BUTTERFLY — 1. Randy Danko

(Annopolis), 1:00.8; 2. Todd Green (Clarenceville), 1:02; 3. Mark Perham (Woodhaven), 1:03.5; 4. Gregg Kepes (Oak Park), 1:05.2; 5. Rich Truskowski (Woodhaven), 1:05.5; 6. John Hill (Clarenceville), 1:07.5.
100-YARD FREESTYLE — 1. Mark Truskowski (Woodhaven), 54.0; 2. Pat Winslow (Annopolis), 56.5; 3. Jon Murphy (Woodhaven), 57.1; 4. Paul Marchyok (Annopolis), 57.4; 5. Warren Ross (Annopolis), 57.9; 6. Mark O'Neill (Clarenceville), 58.9.
500-YARD FREESTYLE — 1. Paul Larson (Clarenceville), 5:24.6; 2. Paul Kurtzhals (Woodhaven), 5:43.6; 3. Keith Bo (Woodhaven), 5:52.7; 4. Chris McCoy (Woodhaven), 5:52.7; 5. Don Vader (Clarenceville), 5:55.4; 6. Jerry Calloway (Annopolis), 6:00.0.
100-YARD BACKSTROKE — 1. Bill Casey (Annopolis), 1:00.4; 2. Todd Green (Clarenceville), 1:03.0; 3. Mike Yanko (Oak Park), 1:04.5; 4. Jim Cronan (Woodhaven), 1:06.6; 5. Tom Winter (Woodhaven), 1:08.6; 6. John Fallu (Woodhaven), 1:11.9.
100-YARD BREASTSTROKE — 1. John Hill (Clarenceville), 1:06.9; 2. Pete Bloye (Annopolis), 1:09.1; 3. Rob Walter (Clarenceville), 1:11.1; 4. Mark Maher (Woodhaven), 1:18.8; 5. Gregg Kepes (Oak Park) and David Yanko (Oak Park), disqualified.
400-YARD FREESTYLE RELAY — 1. Woodhaven (Rich Truskowski, Mark Truskowski, Paul Kurtzhals and Jon Murphy), 3:45.1; 2. Clarenceville, 3:57.3; 3. Annopolis, 3:58.1; 4. Oak Park, 4:07.0.

Area swimming coaches are encouraged to contact Livonia Bentley coach Keith Wright, who is compiling a weekly listing of the best times for the Observer. Wright may be reached at 422-3070, 8:30 a.m. to 11:30 a.m., Fridays and Mondays.

Brad George (Frank)	2:07.5	500-YARD FREESTYLE	Kurt Bonatz (CC)	4:54.4	
John Cassidy (Frank)	2:07.7	Kurt Bonatz (CC)	4:55.0	Tom Hankins (CC)	4:55.2
Paul Dudley (Frank)	2:07.9	Jon Morgan (RU)	4:55.2	Paul Dudley (Bent)	4:57.5
50-YARD FREESTYLE					
Frank Sugrue (CC)	22.5	Greg Dawkins (Glenn)	4:59.8	Matt Caslin (CC)	4:59.8
John Cullen (CC)	22.7	Paul Schröder (CC)	5:04.6	Mark Devore (GC West)	5:06.6
Mark Mysteravich (CC)	22.7	100-YARD BACKSTROKE			
Peter Klebba (CC)	22.8	Pat Schoff (Steve)	57.8	John Herkens (Frank)	58.0
Jim Miloch (RU)	22.8	John Cassidy (Frank)	59.6	John Cassidy (Frank)	1:00.0
Brian Cullen (Glenn)	22.8	Gary Porporo (Bent)	1:00.1	Mike Schultz (CC)	1:00.7
Keith Wagner (Church)	21.00	Pat Ross (GC West)	1:00.7	Art Klugo (CC)	1:00.7
Todd Fiedel (Salem)	19.15	Bob Simrak (Canton)	1:01.0	100-YARD BREASTSTROKE	
Dave Mulliet (GC East)	19.15	100-YARD FREESTYLE RELAY			
100-YARD BUTTERFLY					
Brian Hurley (CC)	53.9	Matt Caslin (CC)	1:02.2	Mike Weker (CC)	1:02.6
Jim Miloch (RU)	53.9	Phil Wojcik (Bent)	1:04.0	John Ravenna (Steve)	1:04.1
Mike Ward (CC)	55.9	Dave Wilcox (Glenn)	1:04.7	John Cassidy (Frank)	1:04.7
Ken Stark (RU)	56.1	Gary Workman (Salem)	1:05.8	Roger Knight (Frank)	1:05.7
Brad George (Frank)	56.2	Don Conn (CC)	1:06.2	400-YARD FREESTYLE RELAY	
Joe Radcliff (Salem)	56.6	Catholic Central			3:19.0
Dan Leveck (Cville)	56.7	Livonia Stevenson			3:24.9
Bill Colwell (Steve)	56.8	Livonia Bentley			3:26.0
Brian Cullen (Glenn)	218.00	Redford Union			3:28.3
Keith Wagner (Church)	199.55	Westland John Glenn			3:27.8
Todd Fiedel (Salem)	199.25	Plymouth Canton			3:30.8
Dave Mulliet (GC East)	199.15	Garden City West			3:32.1
200-YARD FREESTYLE					
Paul Dudley (Bent)	48.8	Livonia Franklin			3:32.2
Pete Klebba (CC)	48.8	Garden City East			3:35.9
Greg Dawkins (Glenn)	49.7	Livonia Churchill			3:35.8
Mark Devore (GC West)	49.7	Redford Thurston			3:37.4
Frank Sugrue (CC)	49.9	Clarenceville			3:58.7
Mata Marsel (Steve)	50.4				
Mark Mysteravich (CC)	50.6				
John Cullen (CC)	50.6				

HAGGERTY HAS IT!

Damp Weather Specials

Super Size Roofing Shingles

At a super price

235 lbs. Also available at Howell in 6 Different Colors

\$24⁹⁵ Square Cash & Carry

- Liquid Roof Coating \$15⁹⁹
5 Gal. Pail
- Liquid Roof Coating WETBOND (Can be used in damp weather) \$18²⁵
5 Gal. Pail
- Plastic Roof Cement \$4¹⁵ Gal.
- Plastic Roof Cement WETBOND (Can be used in damp weather) \$4⁴⁰ Gal.
- 5" Aluminum Gutter 10' Section
\$4⁸⁸ Reg. \$5.88

10% OFF ALL GUTTER FITTINGS

CLIP

These Valuable COUPONS

Haggerty Has It's COUPON

LIQUID NAILS PANEL ADHESIVE

Reg. \$1.69

88¢

11 oz. tube

Good thru 3-17-81

Haggerty Has It's COUPON

DOW BATHTUB SILICONE CAULKING

Reg. \$6.59

\$3⁸⁸

10.7 oz. tube

Good thru 3-17-81

Haggerty Has It's COUPON

HANDYMAN'S ASSORTED NAIL PACK

Reg. \$1.29

50¢

5 lb. box

Good thru 3-17-81

Haggerty Has It's COUPON

Ruff-It

Reg. \$15.99

\$9⁴⁹

Good thru 3-17-81

Haggerty Has It's COUPON

ELECTRIC WIRE

250' 14/2 w/ground **\$18⁸⁸**

250' 12/2 w/ground **\$25⁸⁸**

Good thru 3-17-81

Armstrong SUSPENDED CEILING TILE

\$1⁴⁹ Tile

#943 Textured Fashiontone 2'x2'

FREE suspended ceiling grid

with purchase of tile*
*up to 4' of 2000 series grid per 2'x2' tile, white only.

Valspar DRY BASEMENTS!

BEFORE AFTER

SAVE \$3.00

\$11⁹⁹

C&C

SAVE 20% OFF ALL ALUMINUM STEP & EXTENSION LADDERS

Extension Ladders

16ft. Flat Step
Maximum Working Length 17 ft.

20ft. Reg. \$64⁹³

24ft. Reg. \$94⁸⁷

28ft. Reg. \$139²⁰

Maximum Working Length 25 ft.

Other Sizes Available

Step Stool

26" high
Sturdy and light
Perfect for household chores

Reg. \$18⁹⁹

Step Ladder

5 ft. high
6 ft. Reg. \$32⁷⁸

Reg. \$40⁹⁹

5 ft. high
Reg. \$29⁹⁹

4 1/2 ft. high
Reg. \$29⁹⁹

Perfect for household chores

Platform Ladder

4 1/2 ft. high
Reg. \$29⁹⁹

Perfect for household chores

TARPAULINS

- Heavy Duty
- Waterproof
- Mildew proof

35¢

SQ. FT.

Compare at 60¢ sq. ft.

Interior Pre-Hung Door

1 3/4" Thick

	Laun	Birch
2"x6"	28.30	32.75
2"x6"	29.50	34.50
2"x6"	30.00	36.00
2"x6"	33.00	39.00
3"x6"	34.50	40.50

Includes: F.J. Jamb, Stops, Hinges Drilled for Hardware

HAGGERTY LUMBER & SUPPLY CO.

WALLED LAKE • 2055 Haggerty Rd.
(313) 356-6166 / (313) 624-4551
Mon.-Fri. 8-6, Sat. 8-5 • Sun. 10-3

HOWELL • 227 N. Barnard
(517) 546-9320
Mon.-Sat. 8-5 • Sun. 10-3

PRICES GOOD THRU MARCH 17, 1981 ALL PRICES

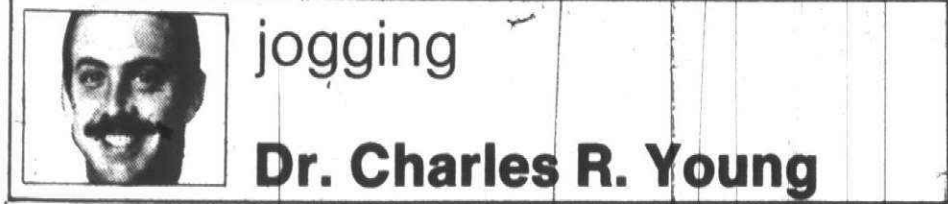

jogging

Dr. Charles R. Young

Have all the facts before foot surgery

The purpose of any surgery is to alleviate an existing problem. When performed by a competent surgeon under the right circumstances, success is highly likely.

However, unlike aluminum-siding guarantees on television, surgery has its problems. No warranties on parts and labor can be issued by the doctor. The full ramifications of surgery should be well-understood prior to its undertaking.

When necessary, foot surgery can be a wonderful solution to a painful condition. It is not, however, a substitute for good conservative care.

Certain types of foot problems lend themselves to a non-surgical approach while others respond poorly.

With few exceptions, foot surgery on the athlete is not unlike surgery upon any other type of patient.

TO THE PHYSICIAN, surgery represents a corrective procedure to alleviate an annoying problem. To the patient, the very thought of surgery involves all sorts of anxieties and fears.

Through confidence in your doctor, and a good understanding of the problem, you can deal with many apprehensions.

If a particular foot procedure is considered the correct approach, several factors should be considered.

First, and most importantly, you should feel confident that foot surgery is necessary. Potential gains and the possible complications of the procedures also should be considered.

Are you better off to wait?

Has a conservative approach been attempted? Will the problem worsen and interrupt your function if not corrected? What are the success rates and benefits of the procedure?

Your foot specialist should answer these questions.

In turn, you will gain confidence in the upcoming procedure.

OPERATIVE PROCEDURES can be scheduled to fit the patient's activity schedule. Usually, we try to perform the foot surgery off-season, thus allowing the athlete time to complete the involved season.

The merits of this become increasingly obvious as we move into the scholarship, collegiate and professional realms.

Most importantly, the patient's health and welfare should be maintained. It must be felt that continued athletic participation will not cause permanent disability. Otherwise, the delay is foolish and possibly hazardous.

Foot surgery should be performed with an emphasis upon functional gains and stability. The involved part should be able to move, carry weight and function as normally as possible.

Depending upon the extent of the involvement, this is not always a reality. Nevertheless, it is the surgical goal.

The patient should be well-informed as to the realistic expectations of undergoing the procedure.

A well-informed patient is better able and more willing to cooperate during the post-operative period — and therefore more likely to reach certain plateaus. Such a patient often will exceed the doctor's expectations through sincere effort and sound attitude.

ANY DISCUSSION of foot surgery would be incomplete without mentioning proper rehabilitation.

Techniques may vary from office to office, but the operative foot must be restrained, exercised and built-up prior to returning to athletic participation.

Southfield battles courageously

Tall cagers win regional test

By DENNIS O'CONNOR

It was a classic struggle — size, strength and talent vs. pure emotion. In the end, the talent prevailed.

Southfield High played with all its heart, and actually threatened the giants from Birmingham Brother Rice in the third quarter.

But the Warriors regrouped in time for a 66-55 regional basketball victory before an overflow crowd of 2,200 Tuesday night at Southfield-Lathrup. Rice, the No. 1-ranked team by the

Observer & Eccentric, takes its 20-3 record into the regional championship game at 7:30 p.m. tomorrow at Lathrup.

The Warriors face the winner of Wednesday's Ferndale-Center Line contest.

The Blue Jays, ignoring an "intimidating" 37-27 Warrior halftime lead, came out and scored the first six points of the second half and controlled the tempo with their run-and-gun, transition game. Southfield forced numerous turnovers in that period, pulling within

two points on two different occasions.

But Southfield could never get over the hump, failing to avenge last year's 60-57 regional-final defeat to the Warriors.

LES DAGGS, Rice's senior guard who finished with 18 points and four assists, sank a 22-foot at the buzzer to give Rice a 47-43 lead after three quarters. Daggs opened with two more baskets in the fourth quarter to stake Rice to an eight-point margin.

Southfield, relying all night on its perimeter shooting over the tall Rice front line, hit only two of 18 shots in the first five minutes of the fourth quarter — both baskets by Ed Murden.

The Blue Jays never got closer than six points in the final quarter, and Rice settled into a 2-3 zone defense in the final three minutes to protect its victory.

"We just couldn't put it down when we had to," said Southfield coach Greg Sliwka. "We shot 36 percent as a team (25 of 70), and we've relied on transition (and good shooting) all year long."

"Like Darryl (Darden, a senior forward) said, everything just seemed to go their (Rice's) way — a violation here, a turnover there. But when you play catch-up that's what happens."

JUNIOR PAUL JOKISCH, the strongest player in the area, led Rice's with 19 points. And that 6-foot-7 frame pulled down 12 rebounds in helping the Warriors to a 40-30 advantage in that category.

Junior center John Shasky, standing 6-foot-10, added 12 points and 13 rebounds. And the 6-foot-6 junior forward added 11 points.

Dingens and Jokisch each scored nine points in the first half and Shasky added eight to stake Rice to a 10-point halftime margin. The Warriors led 18-8 after the first quarter.

"They (Rice) are so big," Sliwka said. "The kids just didn't quite expect it — their size intimidated us so much."

And Sliwka equally was impressed with Rice's quickness — especially in the third quarter when the Warriors refused to slow things down.

"I give them (Rice) all the credit for running the ball up and down the court with us," The Southfield coach said.

ALTHOUGH RICE COACH Bill Norton uncharacteristically switched to the zone defense late in the game, he said he wasn't concerned about controlling the tempo of the game.

"We not big on controlling tempo with this team as we've been in the past two years," Norton said. "We look for the holes (in the opponents' attack) and go after it. But we let down (in the third quarter)."

"We strive for consistency. That's why if we ever go with a surge, then we can bury somebody."

Southfield, a young team which featured only one experienced player in Darden, was led by Rick Ziegler's 14 points. Darden, Murden and junior Ralph Walker added eight points each.

Rice's victory over the Blue Jays breaks a 1-1 career record between these two cage squads. Rice has won both regional battles in the last two years, but Southfield won the first game, 59-46, way back in the 1964-65 season.

swimming

JUNIOR SWIMMING
Milan 317 — Plymouth Canton 203
Cruiser 1st place finishers
MEDLEY RELAY

GIRLS 11-12 — Michelle Stackpole, Cindy Elliott, Lori Shaffer and Kathy Kennedy, 2:19.0, 200 yards.

BOYS 13-14 — Jim Casler, Steve Swartzinski, Mike Harwood and Chuck Eudy, 2:04.5, 200 yards.

FREESTYLE RELAY

GIRLS 11-12 — Stackpole, Elliott, Shaffer and Kennedy, 2:01.9, 100 yards.

SPECIALTY BUTTERFLY

GIRLS UNDER 8 — Kellie Adamczak, 20.4, second.

and place, 25 yards.

BOYS 9-10 — Scott Swartzweiler, 38.2, third, 50 yards.

GIRLS 9-10 — Erin Olson, 38.3, second, 50 yards.

BOYS 11-12 — Don Harwood, 33.7, third, 50 yards.

GIRLS 11-12 — Shaffer, 33.2, second; Kennedy, 33.5, third, 50 yards.

BOYS 13-14 — Mike Harwood, 1:07.0, second, 100 yards.

GIRLS 13-14 — B.J. Bing, 1:10.2, first; Theresa Shaffer, 1:15.2, second; Kim Vesnaugh, 1:23.0, third.

basketball

Junior playoff results

PLYMOUTH-CANTON
JUNIOR BASKETBALL ASSOCIATION
Playoff results

GIRLS AA — Jets 39, Angels 26 (championship).
GIRLS B — Apollos 24, 76ers 19, Nets 23, Angels 14, Stars 22, Blues 21, Dolphins 22, T-Birds 16 (quarterfinals).
Apollos 22, Stars 11, Nets 22, Dolphins 9 (semifinals).

Apollos 23, Nets 10 (championship).
BOYS AA — Gophers 54, Wildcats 42; Wolverines 45, Badgers 36 (semifinals).
Gophers 52, Wolverines 32 (championship).
BOYS A — Lakers 54, Bullets 38, Chargers 51, Stags 39, Royals 27, Hawks 21, Pistons 36, Celtics 32 (quarterfinals).
Royals 51, Lakers 35, Pistons 36, Celtics 32 (semifinals).

NOTICE TO BIDDERS HOUSING COMMISSION

CITY OF PLYMOUTH, MICHIGAN

Notice is hereby given the City of Plymouth Housing Commission will receive sealed bids up to 11.00 a.m., Thursday, March 26, 1981, for the following:

"PUBLIC AREA FURNITURE FOR ADDITION TO TONQUISH CREEK MANOR"

Specifications for quotations are on file in the Office of the Housing Commission, 1160 Sheridan, Plymouth, Michigan, and may be procured at any time during normal office hours. Additional information is available from the Housing Director.

SHARON LEE THOMAS, Director
Plymouth Housing Commission

Publish March 12, 1981

HOME & GARDEN AN UNBEETABLE GUIDE!
Monday, April 13

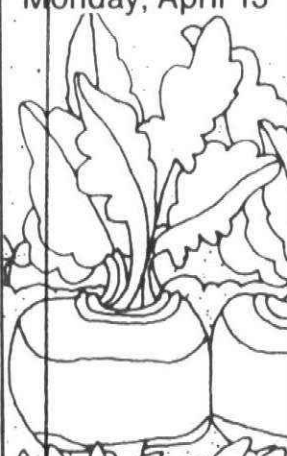

Heavy Duty MUFFLERS

We Do Good Work
Most Ford V-8 Systems
Most G.M. V-8 Systems

r w/single muffler — \$109⁹⁵ CLAMPS FREE

DISCOUNTS ON MOST OTHER EXHAUST SYSTEMS FREE LABOR C-CLAMPS	MOST LATE MODEL G.M. SYSTEMS (Converter Back) \$84 ⁹⁵	TRUCKS, VANS, CAMPERS & FOREIGN CARS WELCOME	BRAKE & AUTO REPAIR SPECIALISTS
---	--	--	---------------------------------

CUSTOM PIPE BENDING
CONDITIONAL LIFETIME GUARANTEES
FREE BRAKE INSPECTION WITH THIS AD

We fix any car, old or new, low prices. Before you buy check our prices. VANS & CAMPERS AND TRUCKS WELCOME

Schoolcraft Auto Service & Muffler Shop, Inc.
36913 Schoolcraft, Livonia
591-0679 or 591-0678

THE EXPRESS OIL SHOP

— 12 MINUTE OIL CHANGE —

- CHANGE OIL — Includes up to 5 qts. of 10W40 Pennzoil
- INSTALL NEW OIL FILTER
- CHECK AIR PRESSURE IN TIRES
- CHECK AIR FILTER
- LUBRICATE

ALL THIS FOR ONLY \$11.95

By-RITE OIL COMPANY
OPEN MON. THRU SAT. 9 AM - 7 PM

2 LOCATIONS
• 31295 Ann Arbor Tr. - 421-9842
(corner Ann Arbor Tr. - Merriman)
• 27153 W. 7 Mile • 592-9006
(2 bks. E. of Inkster)

\$37.50 SAVE \$37.50 FREE ENERGY SURVEY

SAVE UP TO 50% ON UTILITY BILLS

DRYER VENT SYSTEM
Let your dryer put warm, moist air back in your home, instead of outside.

INSULATING WINDOW FILM
Year Round Savings
Cut Your Heating/Cooling Fading/Glare

Up to 40% in winter
Up to 80% in summer

ENERGY SAVER
• No Moving Parts
• Savings on both on/off cycles
• Approved by the American Gas Association

-PLUS MORE- CAN YOU AFFORD NOT TO CALL? Controlled ENERGY of TROY 644-2844

Hobby House's Robbery Great Train Sale

Save 25% on all

- Rolling Stock • Track
- Engines • Scenery • Books

Brand Names Like
• Atlas • Troller • Lionel • KADEE
• Life Like • MRC • AHM • Athearn
• Tyco • MDK • Woodland Scenics

Also Many In-Store Specials On
TYCO ROAD RACE ACCESSORIES

Sale Ends Saturday, March 28, 1981

Some Quantities Limited to Stock on Hand

COUPON

Troller 5000 Transistorized POWER PACK with
• 4 Monitor Lights
• Realistic Slow Speed Acceleration
• 5 Year Warranty
• Pump Action Brake - U.L. Approved

List \$56.95 **\$29⁹⁵**

With This Coupon

COUPON

Bachman YARD BOSS
N-Scale

Train Set
50% OFF
List \$54.20 **\$27¹⁰**

With This Coupon

COUPON

Troller 30 Transistorized TWIN POWER PACK with
• Reversing Controls
• 2 Monitor Lights - U.L. Approved
• Realistic Slow Speed Acceleration

List \$34.95 **\$24⁹⁵**

With This Coupon

COUPON

Bachman BULLET

HO TRAIN SET

- ENGINE
- 4 CARS
- TRACK
- TRANSFORMER

Includes Trestle Bridge with Blinking Light

Great Deal On A Great Starter Kit
List \$48.35 **\$24¹⁷**

50% OFF

COUPON

We Want to Be Your Hobby Store
Come In and Browse

HOBBY HOUSE INC.

THE CREATIVE FAMILY'S HOBBY STORE
8208 Merriman Rd. Westland, Mi.
425-9720
Open: Mon. Tues., Thurs. 4 Fri. 10-8
Wed. 12:30-8 Sat. 10-6

LIVONIA BUILDING MATERIALS CO.

12770 Farmington Road
(S. of Schoolcraft Road)
Livonia

937-0478 421-1170

DRYWALL IN STOCK

	4x8	4x10	4x12	4x14
3/8"	3.77			
1/2"	3.80	4.75	5.70	6.65
5/8"	4.60	5.80	6.90	8.10

Stick 'em up... with **MACCO Liquid Nails** CONSTRUCTION ADHESIVE
6-11 oz. CART. \$7.20
INDIVIDUALLY \$1.29
OFFER EXPIRES APRIL 3, 1981

MON.-FRI. 8-5 SAT. 8-12

Thursday, March 12, 1981



Order the saguaro with ranch dressing



travel log

Iris Sanderson Jones
contributing travel editor

Cookin' vacations north on the range

Doris Scharfenberg's story about horseback riding in Arizona which is featured on this page, reminds me of another ranch experience, in what people have called the Texas of the North Alberta, Canada.

Alberta joins the prairies to the Rocky Mountains, so its foothill country is perfect for raising cattle. Fur trading was at the beginning of its history, and oil is its current crop, but ranching has been important in Alberta for 100 years.

A growing number of ranches are both working ranches and guest ranches, especially in the country between Rocky Mountain House, where the fur trade began, and Drumheller, where a large number of dinosaur skeletons have been found.

WE ARRIVE at Rocky Mountain House on a modern highway, but the film by Parks Canada shows graphically how the voyagers and the fur traders had to move across this land centuries ago.

It was the fur traders who opened up all this western land by canoe in an effort to provide beaver skins for the European market.

There is not much left of this important fur-trading post now, but it is one of several forts in the area being excavated and restored.

Southwest, at Drumheller, we are taken well before the fur-trading era to the era of dinosaurs. This is the land that yields dinosaur bones, which can be seen in museums all over the world.

A beautifully restored dinosaur skeleton, the Edmontosaurus, is on permanent loan as the centerpiece of the Drumheller Dinosaur Museum. A few miles away, where the soft soil has been washed away to form dry spires of land, called Hoodoos, we look across Horseshoe Canyon to the Red River Badlands.

IN BETWEEN Rocky Mountain House and Drumheller, and in foothill country all around Alberta, are a growing number of small guest ranches for one, two or a dozen travelers.

We stopped at the T and L Ranch, owned by the Lynch family, out there are many such ranches here in dinosaur country.

Another, Green's Farm, takes 10 guests at rates of \$200 a couple per week, including meals, entertainment, horseback riding and riverboating. The A&H Farm of Amos and Heather Neufeld of Elnora, offers all of the above as well as pack trips and hayrides.

George and Esther Vermillion run the Diamond 4 Guest Ranch 18 miles away, 800 acres for \$20 a day or \$125 a week.

The Lynch family houses guests in their own ranch house or adjacent cabin. They also provide camping space for people who want to stay overnight or by the week and either cook their own meals or eat with the family at the house.

ONE OF THE unusual features of a ranch vacation in this area is fossil hunting on the nearby hill. So far there is no law against removing small fossils from these unprotected areas, and it is easy to find them.

Travel Alberta offers a brochure called "Ranch Vacations in Alberta." Ranch vacations have become so popular they are offered by some travel agents as an air tour adventure package. Many of these ranches offer both summer and winter vacations.



Guests at the Tanque Verde Ranch ride out to a chuckwagon breakfast of hotcakes, sausage and biscuits.

Story and photos:
DORIS SCHARFENBERG

TUSCON, Ariz. — I was standing in the most unlikely international rendezvous on earth, a pungent corral on the edge of a cactus-filled desert, about to do something I never do — ride a horse.

The voices around me, giggling and joking, were Japanese, German, French, New York and probably mid-town Flint. We were guests at the Tanque Verde Ranch, one of Tucson's many posh and popular western resorts, about to ride out into the sage and saguaro for a chuckwagon breakfast.

"How did you happen to come here?" I asked a tiny Japanese woman who rode like a veteran.

"My husband is bird-watcher," she said. "He found desert birds most interesting and once, while driving through, decided to come on vacations."

The Germans came because they loved horses, and it was so different. "No scenery like this in the Rhineland," they said laughing.

"Besides, wait til you get to the breakfast! Worth coming 6,000 miles for."

THE AIR WAS clear as crystal. The landscape of saguaro cactus standing tall against a background of angular mountains reflecting morning sun was beautiful.

My unaccustomed bones survived the ride, and the breakfast — sausages, pancakes, biscuits and the general works — was supreme.

Although missing such events because of horse-shyness would be too bad, you don't have to get into a saddle when you vacation in Tucson. The old-time ranches have evolved into glamour spas with swimming pools and tennis courts as standard equipment.

Skin care clinics and art classes are tucked into daily routines, along with trips to a dozen points of interest around Tucson.

The city spreads across the heart of southern Arizona's cactus country, a swift-growing urbana of gleaming towers and low earth-hugging Spanish architecture. Constituting an inner city of its own, the University of Arizona is a 30,000-student complex with all the lively goings-on of a campus that size.

TUCSON MIXES the old with the new like crossed threads of the same cloth. The visitor with the untrained eye sometimes needs a little help sorting out authentic Tucson. Authentic-looking duplicates of old inns, and well-kept but ancient structures stand side by side.

When you are in front of the San Xavier Mission, however, there is no doubt. One of the finest examples of mission design in the United States, San Xavier is still in daily use after 200 years.

One gleaming white tower remains incomplete as a tribute to the worker who fell to his death during construction.

The Arizona-Sonora Desert Museum in Tucson Mountain Park presides over a magnificent forest of saguaro, a tall cactus that doesn't sprout arms for the first 80 years of life, then assumes a humanistic silhouette. It is forbidden to cut one down or even move one without permission.

The sleek, imaginative museum has everything from wildcats to scorpions, and yes they're real. Now switch back to doubt. Down the road from the museum is a make-believe Old Tucson, originally a movie set built for the filming of "Arizona."

The dusty streets and false-front saloons are still used by Hollywood and TV film makers. But now the riders in stage coaches are likely to be visiting Iowans.

REALITY STRIKES again in the person of Arizona artist Ted DeGrazia. DeGrazia sells more prints, plates and cards of his own work than any other person alive.

He hand-built his studio and museum to vaguely resemble the mines he worked while struggling to become an artist.

The University of Arizona has published huge volumes of his work, and DeGrazia's card "Los Ninos" was one of the most popular ever sold by UNICEF. On a lucky day, you might find him in his patio-garden or in the small chapel he built next door.

Colossal Cave, the Kitt Peak National Observatory, the Pima Air Museum (largest collection of vin-

tage aircraft in the West). The desert is blooming and so is Tucson.

You can get there by air (Frontier, for example, now has direct Detroit-Tucson flights), Amtrak, bus or highway. The favorite way, however, to get around and see the desert at its best is by horse. For that, a galaxy of resorts are ready to put you into a saddle.

TANQUE VERDE RANCH — High in the foothills, the Tanque Verde borders the million-acre Coronado National Forest. It offers a textbook example of wide open spaces. Two heated pools, health club and classy dining room aside, horses are still the main attraction at the 130-year-old establishment with one of the largest guest stables in Arizona. Route 8, P.O. Box 66, Rincon Foothills, Tucson, Ariz 85710

WESTWARD LOOK — A short ride from downtown Tucson, the Westward boasts elegant rooms, balconies, paths, flowers and super scenery. The dining room is one of the best in the state with tailored waiters pulling flaming miracles out of tableside pans. They've got a nightclub, and Ma Nature's sunsets are spectacular. 245 E. Ina Road, Tucson 85704

CANYON RANCH — This multi-million dollar vacation fitness resort, is part of a condominium community where overnight guests are welcome. They'd rather you stay a week, however, so they can feed you a tailored-to-you diet (if you want), show you how to breathe properly (if you want), or they'll leave you strictly alone (if you want.) 8600 E. Rockcliff Road, Tucson 85715

BRAVE BULL RANCH — Here is where you can join wildlife artist Ray Harm on jaunts over secluded mountain trails. Harm's paintings line the lobby. Along with invitations to use the heated pool, you can see the movies or have a snack brought to your private patio. Free pickup available at Tucson International Airport. Route 18, Box 335, Tucson 85704

For more information: Tucson Visitors Bureau, P.O. Box 27210, Tucson, Ariz. 85726.

Mini-Vacations. Minutes Away.

Need to get away from it all? And SAVE GAS, jump into your car and drive to the Northfield Hilton for a super weekend fling at an un-super little price. Go ahead - spoil yourself. You deserve it.

UNWINDER

- Luxurious room
- Cocktail in Hurley's, our contemporary lounge with nightly entertainment and dancing on a stainless steel dance floor
- All-season indoor pool
- Saunas
- Leisurely breakfast in Wicker Works (or room service)
- Free parking
- \$37.81 per person, double occupancy



HONEYMOONING

- Luxurious room
- Bottle of champagne
- Entertainment and dancing in Hurley's
- Indoor pool and saunas
- Leisurely breakfast in Wicker Works (or room service)
- Free parking
- \$70 per couple

Tips and taxes are included! Call 879-2100 for color brochures on our Unwinder and Honeymooning packages.

NORTHFIELD HILTON
500 Crooks Rd. at I-75
Troy, Michigan 48068
(313) 879-2100

CANADA WEST

Tour Rockies and Vancouver
From \$402 Canadian or \$334 U.S.

AIRFARES

• Windsor/Vancouver Return ... \$319 Canadian or \$265 U.S. • Windsor/Los Angeles Return ... \$349 Canadian or \$289 U.S. • Windsor/Honolulu Return ... \$686 Canadian or \$570 U.S.

For Information CALL 963-6104

1011 OULETTE AT ERIE
3 blocks from Tunnel in Windsor

HOME & GARDEN HAS A PEEL!

Watch for it! Monday, April 13

ORLANDO

7 DAYS 329⁰⁰*

Fly round trip. Make a dream come true for your entire family. Stay at a lovely hotel. Close to Disney World. Your kids can fly round trip for \$182.00 and we include an extra bonus: Kids stay FREE at the hotel. Includes car rental, air fare, hotel. — All per person.

*All prices per person, double occupancy and include accommodations and round-trip airfare. All prices are subject to change without notice. Prices depend on date of departure and type of accommodations, and are subject to availability.

Thomas Cook Travel

Birmingham
280 N. Woodward
647-7750
Southfield
27777 Franklin Rd.
353-1470



second runs

Tom Panzenhagen

"Manhattan" (1979), 7:30 and 10 p.m. Friday and Saturday at the Cass City Cinema, 4605 Cass at Forest, phone 832-6309. \$2. Running time 93 minutes.

"Manhattan" is Woody Allen's best film because it is his most even and complete work. "Annie Hall" shows "alliance on a plot level and 'Stardust Memories' on a stylistic plane, but 'Manhattan' excels from start to finish — in word (Woody Allen), photography (Gordon Willis) and music (George Gershwin).

Few films exhibit a literary quality — that is, place style on the same level as plot; accentuate point of view through a narrative form and establish character development with camera

WHAT'S IT WORTH?
A ratings guide to the movies

Bad	\$1
Fair	\$2
Good	\$3
Excellent	\$4

technique rather than only action. "Manhattan" is a literary film. Structurally, "Manhattan" begins as a novel begins: In a voice-over Allen's character tries to begin a book about New York City. His false starts lead into the film proper, showing the protagonist as uncertain of what he wants but positive of what he despises. Mar 21 Hemingway, as his young girlfriend, is

fabulous. She does not act well, but she doesn't have to because Allen knows how to shape his actors to any form he desires.

As the film takes shape, it's fascinating how the roles of Allen and Hemingway become reversed, and the final sequence of the movie — with Allen running crosstown to catch Hemingway before she leaves the country — is masterful. Diane Keaton and Meryl Streep also star. Rating: \$3.98.

in 1908 and Elmo Lincoln played the first film Tarzan in 1914. About a dozen other actors have essayed the Ape Man; the next Tarzan film sounds novel — Bo Derek will star as Jane. Rating: \$2.95.

"The Quiet Man" (1952), 11:30 p.m. Saturday on Ch. 2. Originally 129 minutes.

This film represents something of a departure for director John Ford and John Wayne, who had teamed in several historical westerns in the years prior to the release of "Quiet Man." Set in Ireland, the character Wayne portrays is in charge of his life and the clear focus of the film; in the westerns, Wayne's roles were but a part of the larger action and his fate was determined by the men who made history. Look also for camera shots, or "mise-en-scene," that actually appear painted in this film. One that comes to mind catches Wayne and Maureen O'Hara in a doorway with the wind blowing — it's absolutely stunning. Rating: \$3.60.

"Tarzan Escapes" (1936), 11:30 a.m. Saturday on Ch. 50. Originally 95 minutes.

Ah, relief. WKBD's series of Tarzan films has wound around again to those which star Johnny Weissmuller and Maureen O'Sullivan. Always entertaining and gently moralistic, the six Weissmuller-O'Sullivan efforts made by MGM between 1932-42 are the best of the Tarzan bunch. Edgar Rice Burrough's first Tarzan story was written



Chateaubriand is not a fine wine.

It's an extraordinary entree served for two. A center cut of beef tenderloin, amid a bouquetiere of vegetables, Sauce Bearnaise. Carved at your table. But like a vintage wine, Chateaubriand is at its best when shared.

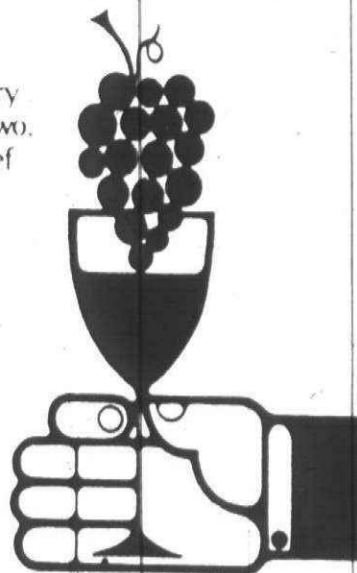

NORTHFIELD BRICK
5500 Crooks Rd. at I-75
Trox, Michigan 48068
613-879-2100

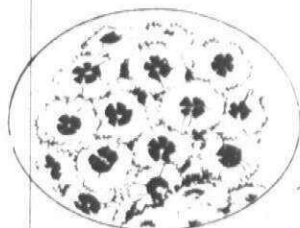

SUBURBAN DETROIT THEATRES.

Bargain Evenings Monday-Thursday

All Seats \$2
All Theatres

Mat. Wed 1 show
1 p.m. \$1.50
except Abbey

ABBEY 1

Across from Oakland Mall on 14 Mile at I-75
588-0881
Matuses Jarry
1 p.m. \$1.50
Sat & Sun Continuous
Richard Pryor
Gene Wilder
"STIR CRAZY" (R)

ABBEY 2

Paul Newman
Ed Asner
"FORT APACHE, THE BRONX" (R)

ABBEY 3

"ALTERED STATES" (R)

ABBEY 4

Starts Fri.
Goldi Hawn
"PRIVATE BENJAMIN" (R)

FAIRLANE 1

Ford Rd. at Telegraph
461-7205
Last Day

"STIR CRAZY" (R)

Starts Fri.
Sally Fields
"BACK ROADS" (R)

FAIRLANE 2

Lily Tomlin
"THE INCREDIBLE SHRINKING WOMAN" (PG)

MAPLE 1

On W. Maple at Telegraph
attached to Bloomfield Plaza
355-9066

"KAGENUSHA" (R)

MAPLE 2

"GREAT SANTINI" (PG)

MAPLE 3

Mary Tyler Moore
Doris Day, Harold
6 Academy Award
Nominations
"ORDINARY PEOPLE" (R)

NORTHLAND 1

Jl. Hudson Dr. Northland Center
555-5366

"ALTERED STATES" (R)

NORTHLAND 2

"EYEWITNESS" (R)

OLD ORCHARD 1

On Ch. Ford Lake Road
North of I-75 Mar. 550-2210

"FOR APACHE, THE BRONX" (R)

OLD ORCHARD 2

Starts Fri.
Sally Fields
"BACK ROADS" (R)

OLD ORCHARD 3

8 Academy Award
Nominations
"ELEPHANT MAN" (PG)

TERRACE 1

30400 Plymouth Road
Near Middlebelt 972-1717

"APOCALYPSE NOW"

Starts Fri.
Goldie Hawn
"PRIVATE BENJAMIN" (R)

TERRACE 2

Last Day
"GREAT SANTINI" (PG)

TOWNE 1

Greenfield Rd. N. of I-75
968-8700
Last Day
Gosnie Hawn

"LOVERS & LIARS" (R)

plus
"HOW FUNNY CAN SEX BE?" (R)

Starts Fri.
Sally Fields
"BACK ROADS" (R)

TOWNE 2

8 Academy Awards
"RAGING BULL" (R)



APPEARING MARCH 16 - 21
HENNY YOUNGMAN
APPEARING SOON



THE TEMPTATIONS
MAR. 23 - 28
MELBA MOORE
MAR. 30 - APRIL 4

FOR INFORMATION AND RESERVATIONS
Call Mon thru Sat 9 a.m. - 6 p.m. 593-1234

MUSIC BY
JOHNNY TRUDELL'S ORCHESTRA

HYATT REGENCY DEARBORN

MOY'S RESTAURANT
CANTONESE & AMERICAN FOOD
JAPANESE STEAKHOUSE
EXOTIC COCKTAILS
Carry-outs on Chinese Food
CHINESE: LUNCHEON 11 AM-3 PM
JAPANESE: LUNCHEON 11 AM-2 PM
DINNERS 5-9:30 PM FRI & SAT III 10:30 PM
Closed Mondays
16825 MIDDLEBELT AT 6 MILE, LIVONIA
Reservations Accepted 427-3171

ART SALE
Original Oil Paintings
THIS SUNDAY ONLY!
ONE OF THE BIGGEST SHOWS EVER IN THIS AREA
\$400 FROM
OIL ON CANVAS ONLY
\$1000 FROM
YOU WILL NEVER BE ABLE TO DECORATE YOUR HOME OR OFFICE FOR LESS!
10AM to 5PM 3 BIG LOCATIONS 10AM to 5PM
FARMINGTON HILLS WARREN DEARBORN
GLEN OAKS CC ROYALTY HOUSE DEARBORN INN
ORCHARD LAKE RD. 13 MILE AT VAN DYKE OAKWOOD BLVD.

They're Back! 7 Shows Only!
March 16*-21
Eves at 8:30
Sat Mat, 2:00
Tickets: \$6 to \$15
MC/VISA CTC Outlets
ALVIN AILEY
AMERICAN DANCE THEATER
* MON. MAR. 16 — WJZZ NIGHT!
Join Detroit's only all-jazz radio station at Music Hall when the company performs three dances NEVER BEFORE SEEN IN DETROIT
MUSIC HALL CENTER
CALL 963-7680
350 Madison Avenue at Brush, Detroit
Group rates: 963-7622 No coupons

Meadow Brook Theatre
NOW THROUGH MARCH 22nd
ANOTHER PART OF THE FOREST
by Lillian Hellman
"Another Part of the Forest" is the play to see this season at Meadow Brook. — Jay Carr, Detroit News
... stands among the most distinguished work done by the Meadow Brook Theatre. — Lawrence DeVine, Detroit Free Press
... an evening of absorbing drama! — Helen Zucker, Observer-Eccentric
377-3300
MEADOW BROOK THEATRE IS A CULTURAL PROGRAM OF OAKLAND UNIVERSITY ON THE CAMPUS IN ROCHESTER

TOM'S ON "THE TOWER"
TOWER 92 FM
"THE GREATEST MORNING MAN"
TOM SHANNON
NOW ON WTWR 92 FM 6-10 am

Go fish for something different at York.
York Steak House presents two delicious seafood dishes.
For lunch, a tender, baked filet of fish. With steak fries, crisp garden salad and oven-fresh roll.
Then, for dinner, York's Baked Filet of Fish Almondine. Prepared with lemon butter sauce and sprinkled with freshly toasted almonds. It's also served with a piping hot baked potato, crisp garden salad, and oven-fresh roll. You didn't expect to find great seafood at a family steak house? Come on in to York. And expect the best.
***YORK STEAK HOUSE**
Northland Center • Oakland Mall
Westland Mall
Open Sunday 11 am - 8 pm
Monday - Thursday 11 am - 9:30 pm
Friday & Saturday 11 am - 10 pm

The Observer

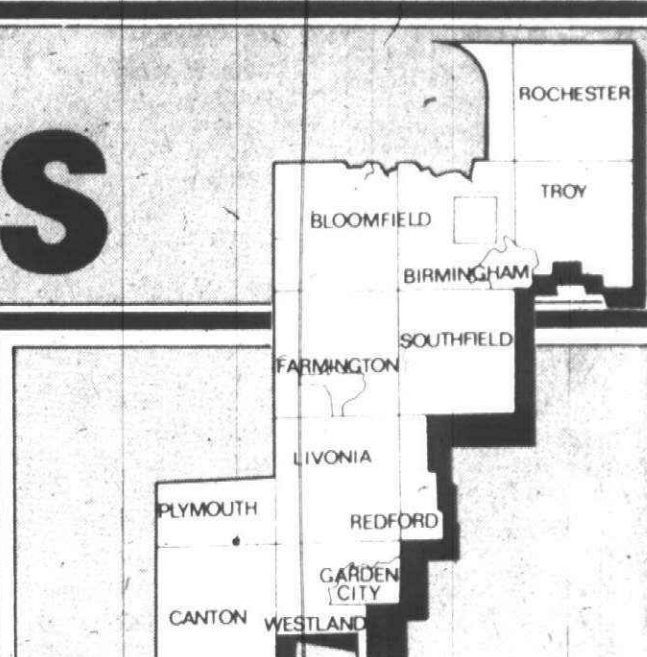

ONE CALL DOES IT ALL! Reach 12 communities with 1 call to 591-0900

REAL ESTATE FOR SALE
302 Birmingham Bloomfield
433 West Bloomfield
304 Farmington

REAL ESTATE FOR RENT
300 Apartments To Rent
401 Condominiums For Sale
323 Livingston County

NOTICES & SERVICES
600 Personal
607 Loan Fund
608 Notary Public

EMPLOYMENT, INSTRUCTION
900 Help Wanted
302 Medical/Dental

MERCHANDISE FOR SALE
Bus 700 Auction Sales
Bus 702 Antiques

AUTOMOTIVE
800 Recreational Vehicles
802 Snowmobiles
804 Airplanes

BUSINESS DIRECTORY
3 Accounting
4 Advertising
5 Air Conditioning

MANAGERS
Are you interested in earning top salary with fantastic growth potential? Here is your chance to join one of the most aggressive retail organizations in the Midwest.

ALBERTS
10811 Northland Ave.
Ferndale, Michigan 48220
MANICURIST Position available Due to Transfer Experienced in Arching, Pedicuring necessary. W. Bloomfield 426-9191

MECHANICAL JUNIOR Draft person with 2 years experience in Auto and Truck Diesel experience preferred. Apply in person 20950 Boening dr. Southfield. Call 483-1188

WE ARE A NATIONAL corporation looking for candidates for our management training program. Our training program will prepare you for a management career with our company. Relocation after 6 months. We are an equal opportunity employer.

500 Help Wanted
A BANK PROGRAMMER
2.4 yrs exp to \$27,800 Analyst 4.6 Yrs exp to \$30,000. Experience required. LMS, T.L.I. or Cobol with IBM 360, 370, 3030 series background. Fee Paid Employment Center. 544-0616

500 Help Wanted
APARTMENT MANAGEMENT ASSISTANT TO RESIDENT MANAGER
The Village Apartments in Wixom is looking for an Assistant to the Resident Manager. Applicants should be knowledgeable in office procedures, purchasing, and all aspects of apartment maintenance.

500 Help Wanted
CAREER? TO \$15,000
Expanding nationwide firm has immediate openings for Management talent. If you are energetic and looking for a career, this is it! Some college or management experience preferred. Training and benefits. Call Carol SNELLING & SNELLING 478-3500

500 Help Wanted
ELECTRICIAN
Experienced in industrial maintenance, familiar with 220 & 480 Volts. Liberal employment benefits. No working applications.

500 Help Wanted
HOUSEKEEPER
LIVE IN Room, board plus salary. Ask for Elaine 459-7060

500 Help Wanted
GUARDS
FULL TIME SECURITY SERVICES
31171 W. 10 Mile Farmington 476-4335

500 Help Wanted
MECHANIC GENERAL
Auto and Truck Diesel experience preferred. Apply in person 20950 Boening dr. Southfield. Call 483-1188

500 Help Wanted
MANUFACTURING SUPERVISOR
Established Manufacturer in Northwest area has a permanent supervisory position for a person with 2-3 years of experience in Assembly, Packaging, Inspection & Shipping essential. Familiarity with Pressure sensitive Materials, Screen Printing techniques & Automotive specifications helpful.

500 Help Wanted
DENTAL MEDICAL
ADMISSION COORDINATOR
Dentist/assistant. Immediate openings in major westside Detroit & suburban facilities. Call Today For An Interview MED-STAFF 557-2505

500 Help Wanted
LPN'S TO \$21,000/Yr. WESTERN SUBURBS
Immediate openings in major westside Detroit & suburban facilities. Call Today For An Interview MED-STAFF 557-2505

500 Help Wanted
APARTMENT MANAGEMENT ASSISTANT TO RESIDENT MANAGER
The Village Apartments in Wixom is looking for an Assistant to the Resident Manager. Applicants should be knowledgeable in office procedures, purchasing, and all aspects of apartment maintenance.

500 Help Wanted
CAREER? TO \$15,000
Expanding nationwide firm has immediate openings for Management talent. If you are energetic and looking for a career, this is it! Some college or management experience preferred. Training and benefits. Call Carol SNELLING & SNELLING 478-3500

500 Help Wanted
ELECTRICIAN
Experienced in industrial maintenance, familiar with 220 & 480 Volts. Liberal employment benefits. No working applications.

500 Help Wanted
HOUSEKEEPER
LIVE IN Room, board plus salary. Ask for Elaine 459-7060

500 Help Wanted
GUARDS
FULL TIME SECURITY SERVICES
31171 W. 10 Mile Farmington 476-4335

500 Help Wanted
MECHANIC GENERAL
Auto and Truck Diesel experience preferred. Apply in person 20950 Boening dr. Southfield. Call 483-1188

500 Help Wanted
MANUFACTURING SUPERVISOR
Established Manufacturer in Northwest area has a permanent supervisory position for a person with 2-3 years of experience in Assembly, Packaging, Inspection & Shipping essential. Familiarity with Pressure sensitive Materials, Screen Printing techniques & Automotive specifications helpful.

500 Help Wanted
DENTAL MEDICAL
ADMISSION COORDINATOR
Dentist/assistant. Immediate openings in major westside Detroit & suburban facilities. Call Today For An Interview MED-STAFF 557-2505

500 Help Wanted
LPN'S TO \$21,000/Yr. WESTERN SUBURBS
Immediate openings in major westside Detroit & suburban facilities. Call Today For An Interview MED-STAFF 557-2505

500 Help Wanted
APARTMENT MANAGEMENT ASSISTANT TO RESIDENT MANAGER
The Village Apartments in Wixom is looking for an Assistant to the Resident Manager. Applicants should be knowledgeable in office procedures, purchasing, and all aspects of apartment maintenance.

500 Help Wanted
APARTMENT MANAGEMENT ASSISTANT TO RESIDENT MANAGER
The Village Apartments in Wixom is looking for an Assistant to the Resident Manager. Applicants should be knowledgeable in office procedures, purchasing, and all aspects of apartment maintenance.

500 Help Wanted
CAREER? TO \$15,000
Expanding nationwide firm has immediate openings for Management talent. If you are energetic and looking for a career, this is it! Some college or management experience preferred. Training and benefits. Call Carol SNELLING & SNELLING 478-3500

500 Help Wanted
ELECTRICIAN
Experienced in industrial maintenance, familiar with 220 & 480 Volts. Liberal employment benefits. No working applications.

500 Help Wanted
HOUSEKEEPER
LIVE IN Room, board plus salary. Ask for Elaine 459-7060

500 Help Wanted
GUARDS
FULL TIME SECURITY SERVICES
31171 W. 10 Mile Farmington 476-4335

500 Help Wanted
MECHANIC GENERAL
Auto and Truck Diesel experience preferred. Apply in person 20950 Boening dr. Southfield. Call 483-1188

500 Help Wanted
MANUFACTURING SUPERVISOR
Established Manufacturer in Northwest area has a permanent supervisory position for a person with 2-3 years of experience in Assembly, Packaging, Inspection & Shipping essential. Familiarity with Pressure sensitive Materials, Screen Printing techniques & Automotive specifications helpful.

500 Help Wanted
DENTAL MEDICAL
ADMISSION COORDINATOR
Dentist/assistant. Immediate openings in major westside Detroit & suburban facilities. Call Today For An Interview MED-STAFF 557-2505

500 Help Wanted
LPN'S TO \$21,000/Yr. WESTERN SUBURBS
Immediate openings in major westside Detroit & suburban facilities. Call Today For An Interview MED-STAFF 557-2505

500 Help Wanted
APARTMENT MANAGEMENT ASSISTANT TO RESIDENT MANAGER
The Village Apartments in Wixom is looking for an Assistant to the Resident Manager. Applicants should be knowledgeable in office procedures, purchasing, and all aspects of apartment maintenance.

500 Help Wanted
APARTMENT MANAGEMENT ASSISTANT TO RESIDENT MANAGER
The Village Apartments in Wixom is looking for an Assistant to the Resident Manager. Applicants should be knowledgeable in office procedures, purchasing, and all aspects of apartment maintenance.

500 Help Wanted
CAREER? TO \$15,000
Expanding nationwide firm has immediate openings for Management talent. If you are energetic and looking for a career, this is it! Some college or management experience preferred. Training and benefits. Call Carol SNELLING & SNELLING 478-3500

500 Help Wanted
ELECTRICIAN
Experienced in industrial maintenance, familiar with 220 & 480 Volts. Liberal employment benefits. No working applications.

500 Help Wanted
HOUSEKEEPER
LIVE IN Room, board plus salary. Ask for Elaine 459-7060

500 Help Wanted
GUARDS
FULL TIME SECURITY SERVICES
31171 W. 10 Mile Farmington 476-4335

500 Help Wanted
MECHANIC GENERAL
Auto and Truck Diesel experience preferred. Apply in person 20950 Boening dr. Southfield. Call 483-1188

500 Help Wanted
MANUFACTURING SUPERVISOR
Established Manufacturer in Northwest area has a permanent supervisory position for a person with 2-3 years of experience in Assembly, Packaging, Inspection & Shipping essential. Familiarity with Pressure sensitive Materials, Screen Printing techniques & Automotive specifications helpful.

500 Help Wanted
DENTAL MEDICAL
ADMISSION COORDINATOR
Dentist/assistant. Immediate openings in major westside Detroit & suburban facilities. Call Today For An Interview MED-STAFF 557-2505

500 Help Wanted
LPN'S TO \$21,000/Yr. WESTERN SUBURBS
Immediate openings in major westside Detroit & suburban facilities. Call Today For An Interview MED-STAFF 557-2505

500 Help Wanted
APARTMENT MANAGEMENT ASSISTANT TO RESIDENT MANAGER
The Village Apartments in Wixom is looking for an Assistant to the Resident Manager. Applicants should be knowledgeable in office procedures, purchasing, and all aspects of apartment maintenance.

502 Help Wanted Dental-Medical DENTAL ASSISTANT Experience a must. Livonia area. Call 476-1001

502 Help Wanted Dental-Medical MEDICAL RECEPTIONIST Pleasant individual with problem solving & organizational ability...

504 Help Wanted Office-Clerical ACCOUNTING dept. clerical, part time. Primary functional input in payroll, data processing & other computer data input.

504 Help Wanted Office-Clerical BOOKKEEPER Ladies store needs full charge woman, 3 day week, good salary, many benefits.

504 Help Wanted Office-Clerical FULL TIME entry level position for mature person with good experience in typing and filing...

504 Help Wanted Office-Clerical LEGAL SECRETARIES Dear Legal Secretaries: If you get up in the morning and think 'If I didn't have to go to work today, believe me, it's time for a change in jobs'...

504 Help Wanted Office-Clerical RECEPTIONIST 10AM - 2PM Monday - Thursday Troy branch of national temporary help service needs part time receptionist...

504 Help Wanted Office-Clerical WANTED TYPISTS - 55 WPM For Temporary Assignments For Appl. call:

505 Help Wanted Food-Beverage WAITRESSES, busboy, cooks, pizza maker, dishwashers. Apply in person. Tuesday through Friday, 2:30pm - 6pm.

RED WING TICKET WINNER Please call the promotion department of the Observer & Eccentric by 5 p.m. Friday, March 13, 1981 to claim your 2 free RED WING TICKETS.

Mental Health Workers Males preferred All Shifts, apply Ardmore Acres Hospital 19810 Farmington, Livonia 474-3500

NURSE AIDES 3 to 11:30 P.M. shift & 11 to 7:30 A.M. shift. Apply in person only. FRANKLIN MANOR CONVALESCENT CENTER 26900 Franklin Rd., Southfield 474-8030

Administrative Assistant TO TOP EXECUTIVE One of the busy partners of a successful Southfield Professional firm needs a super secretary to keep up with his pace. Challenging job - the normal executive secretarial responsibilities and also taking minutes at highly confidential meetings and coordinating many details. Excellent salary and benefit program. If interested in a truly "career job", please respond by resume to Mr. Nichols, P.O. Box 691, Southfield, MI 48037.

CENTER POINT FEE PAID \$12,000 Get involved in this take charge spot. Independent attitude helps you work on to back up operations chief. Great location. 562-8900 649-4144

HARRIET SORGE PERSONNEL CLERICAL - Fretter Appliance has an opening for a mature person in clerical department. You'll be responsible for inputting data into CRT, typing skills necessary. Apply in person 35901 Schoolcraft Rd., Livonia, between Ram-9pm Mon thru Fri.

MANSFIELD & ASSOCIATES, INC. LEGAL PERSONNEL 900 Tower Drive Troy, Michigan 48064 879-8832

COMTEL CORP. Seeking responsible person with good phone manner for one girl office. Call for interview. 338-8360

MANPOWER TEMPORARY SERVICES LIVONIA 478-1130 TROY 585-5595

ACCENT YOUR POSITIVE Join our professional sales team. Super bonus plan. FAST START TRAINING. 4 More! Call us today for a confidential interview.

RED WING TICKET WINNER (continued)

REGISTERED NURSE Part time Birmingham OB-GYN office. Call 586-8100

CLERK TYPIST Individual should have typing skills of 25 wpm, previous office experience and enjoy statistical typing.

FLORISTS TRANSWORLD DELIVERY ASSOCIATION 355-9300, ext. 253 An Equal Opportunity Employer

FLORISTS TRANSWORLD DELIVERY ASSOCIATION 355-9300, ext. 253 An Equal Opportunity Employer

FLORISTS TRANSWORLD DELIVERY ASSOCIATION 355-9300, ext. 253 An Equal Opportunity Employer

FLORISTS TRANSWORLD DELIVERY ASSOCIATION 355-9300, ext. 253 An Equal Opportunity Employer

FLORISTS TRANSWORLD DELIVERY ASSOCIATION 355-9300, ext. 253 An Equal Opportunity Employer

FLORISTS TRANSWORLD DELIVERY ASSOCIATION 355-9300, ext. 253 An Equal Opportunity Employer

CONGRATULATIONS! DENTAL RECEPTIONIST - experienced with working knowledge of dental insurance, scheduling calls, etc.

RN - LPN Needed Immediately Medical Care, Inc. 134 W. University, Suite 121 Rochester 656-1888

ADAMS & MARTIN PERSONNEL 1000 S. Woodward Birmingham 646-5600

DIAL A JOB 24 Hour Service To Hear About Our Most Recent Openings. 646-8780

LEGAL SECRETARIES Highly respected established agency serving the legal community in the tri-county area, for over 15 years, has openings for legal secretaries for immediate placement, both permanent and temporary. Fee paid by employer.

NEED EXCITEMENT? Exceptional firm needs Secretary to Sr Writer. Fast accurate typing, dictation a must. \$10,750 Fee Paid. Call 644-4600

SECRETARY Personnel Function GUARDIAN INDUSTRIES - the leader in the glass and photo finishing industry is seeking a Secretary for its Personnel Department. Responsibilities include employee benefit plan administration, permanent full-time position with a salary of \$12,000 per year.

BURGER CHEF Wanted Day Porter, mornings 7am to 7am. Also accepting applications for full time part time day & night positions. Apply in person only 27526 Grand River Livonia, Mi.

ATTENTION Inside Telephone Sales Need clear speaking voice. Sales experience helpful. Self-motivated, good work habits. Mature persons welcome. Hours 8 to 9 PM Mon thru Thurs. 10 to 11 PM Southfield 4450 per hour plus bonus. Prefer someone with no other job. Call weekdays between 9 AM and 5 PM. 557-3200 Ext. 234 Equal Opportunity Employer M/F

DENTAL RECEPTIONIST - experienced with working knowledge of dental insurance, scheduling calls, etc.

RN - LPN Seeking charge Nurse for full or part time for Midshift shift only Westland Convalescent Center, 1979 Facility of The Year. Contact Ms. Heaston 728-6100

COMMERCIAL UNDERWRITER Lovely suburban office. Exceptional opportunity. Permanent position. Excellent benefits. This won't last! Call Jo Smith. 353-2090

CLERK TYPIST Position requires accurate typist with figure aptitude, legible handwriting & pleasant telephone manner, excellent benefits. Full time, some Sat. work. Interview to be taken Thursday & Friday at Tom McQuinn Industries, 32051 Toxley, Madison Hts. Equal Opportunity Employer M/F/H 588-0066

LEGAL SECRETARIES Success in our business is based on our ability to introduce legal secretaries to law firms who are seeking qualified individuals. We have been effective in doing that for several years now. Our list of satisfied clients is long.

OFFICE MANAGER - Experienced for busy but congenial Southfield office. Must have knowledge of payroll, accounting, bookkeeping experience. Send resume to Box 710, Observer & Eccentric Newspapers, 36251 Schoolcraft Rd., Livonia, Michigan 48150

SECRETARY - Troy PH firm needs experienced individual for 2 man office. Good typing & filing skills. Must be well organized self starter. Flexible hours. 649-3760

COOK AND SALAD PERSON Apply in person 3PM-5PM A La Carte Cafe, Southfield 372-0710

CAREER IN REAL ESTATE Graduated commission rate 90% max. (minus 10% in a real estate office). In house training program. Beautiful facilities. Draw. Call Me Durbin - 851-6600

DENTAL RECEPTIONIST - experienced with working knowledge of dental insurance, scheduling calls, etc.

RN's, LPN's, All Shifts, Individualized orientation and in-service according to your needs. Revised pay and benefit package. Flexible scheduling. CAMBRIDGE Nursing Centre South 18200 W. 13 Mile Rd. 647-6500

BE A WINNER WITH WITT We need experienced: SECRETARIES, STENOGRAPHERS, JR. & SENIOR TYPISTS, DICTAPHONE OPERATORS, PBX OPERATORS, WORD PROCESSORS

EXECUTIVE SECRETARY Blooming Hills, proficient shorthand and typing. Excellent management, benefits, \$16,000, fee paid.

LEGAL SECRETARIES Full time, salary based on experience. Southfield. Call for appointment. 649-0888

PERSONNEL AT LAW 3040 TOWN CENTER, SUITE 2580 SOUTHFIELD, MICH 48075

SECRETARY We offer a challenging opportunity for competent individual who has at least 5 years secretarial experience and is accustomed to working in a fast-paced environment. The ideal candidate will have typing skills of 80 WPM, shorthand, dictating equipment experience and a strong numerical aptitude. Word processing experience is beneficial.

COOKS & BUSBOYS Full and part time. No experience necessary. Apply in person ORIGINAL PANCAKE HOUSE 19555 W. 10 Mile Rd. (between Southfield & Evergreen)

REAL ESTATE NETWORK Clear-Fron Realty 27492 Five Mile Rd. Livonia 425-7300

DENTAL RECEPTIONIST - experienced with working knowledge of dental insurance, scheduling calls, etc.

RN's, LPN's Positions available on all shifts, either full or part time, in our skilled nursing facility located in Redford Twp. Revised pay scale and good benefits. Good orientation offered in Geriatric Nursing. Contact Nursing Director between 9AM-3PM at CAMBRIDGE NURSING HOME, W. 18653 Beech Dale, 255-1010 An Equal Opportunity Employer

EXECUTIVE SECRETARY Blooming Hills, proficient shorthand and typing. Excellent management, benefits, \$16,000, fee paid.

EXECUTIVE SECRETARY Blooming Hills, proficient shorthand and typing. Excellent management, benefits, \$16,000, fee paid.

LEGAL SECRETARIES Full time, salary based on experience. Southfield. Call for appointment. 649-0888

PERSONNEL AT LAW 3040 TOWN CENTER, SUITE 2580 SOUTHFIELD, MICH 48075

SECRETARY We offer a challenging opportunity for competent individual who has at least 5 years secretarial experience and is accustomed to working in a fast-paced environment. The ideal candidate will have typing skills of 80 WPM, shorthand, dictating equipment experience and a strong numerical aptitude. Word processing experience is beneficial.

COOKS & BUSBOYS Full and part time. No experience necessary. Apply in person ORIGINAL PANCAKE HOUSE 19555 W. 10 Mile Rd. (between Southfield & Evergreen)

REAL ESTATE NETWORK Clear-Fron Realty 27492 Five Mile Rd. Livonia 425-7300

DENTAL RECEPTIONIST - experienced with working knowledge of dental insurance, scheduling calls, etc.

RN's, LPN's Positions available on all shifts, either full or part time, in our skilled nursing facility located in Redford Twp. Revised pay scale and good benefits. Good orientation offered in Geriatric Nursing. Contact Nursing Director between 9AM-3PM at CAMBRIDGE NURSING HOME, W. 18653 Beech Dale, 255-1010 An Equal Opportunity Employer

EXECUTIVE SECRETARY Blooming Hills, proficient shorthand and typing. Excellent management, benefits, \$16,000, fee paid.

EXECUTIVE SECRETARY Blooming Hills, proficient shorthand and typing. Excellent management, benefits, \$16,000, fee paid.

LEGAL SECRETARIES Full time, salary based on experience. Southfield. Call for appointment. 649-0888

PERSONNEL AT LAW 3040 TOWN CENTER, SUITE 2580 SOUTHFIELD, MICH 48075

SECRETARY We offer a challenging opportunity for competent individual who has at least 5 years secretarial experience and is accustomed to working in a fast-paced environment. The ideal candidate will have typing skills of 80 WPM, shorthand, dictating equipment experience and a strong numerical aptitude. Word processing experience is beneficial.

COOKS & BUSBOYS Full and part time. No experience necessary. Apply in person ORIGINAL PANCAKE HOUSE 19555 W. 10 Mile Rd. (between Southfield & Evergreen)

REAL ESTATE NETWORK Clear-Fron Realty 27492 Five Mile Rd. Livonia 425-7300

DENTAL RECEPTIONIST - experienced with working knowledge of dental insurance, scheduling calls, etc.

RN's, LPN's Positions available on all shifts, either full or part time, in our skilled nursing facility located in Redford Twp. Revised pay scale and good benefits. Good orientation offered in Geriatric Nursing. Contact Nursing Director between 9AM-3PM at CAMBRIDGE NURSING HOME, W. 18653 Beech Dale, 255-1010 An Equal Opportunity Employer

EXECUTIVE SECRETARY Blooming Hills, proficient shorthand and typing. Excellent management, benefits, \$16,000, fee paid.

EXECUTIVE SECRETARY Blooming Hills, proficient shorthand and typing. Excellent management, benefits, \$16,000, fee paid.

LEGAL SECRETARIES Full time, salary based on experience. Southfield. Call for appointment. 649-0888

PERSONNEL AT LAW 3040 TOWN CENTER, SUITE 2580 SOUTHFIELD, MICH 48075

SECRETARY We offer a challenging opportunity for competent individual who has at least 5 years secretarial experience and is accustomed to working in a fast-paced environment. The ideal candidate will have typing skills of 80 WPM, shorthand, dictating equipment experience and a strong numerical aptitude. Word processing experience is beneficial.

COOKS & BUSBOYS Full and part time. No experience necessary. Apply in person ORIGINAL PANCAKE HOUSE 19555 W. 10 Mile Rd. (between Southfield & Evergreen)

REAL ESTATE NETWORK Clear-Fron Realty 27492 Five Mile Rd. Livonia 425-7300

DENTAL RECEPTIONIST - experienced with working knowledge of dental insurance, scheduling calls, etc.

RN's, LPN's Positions available on all shifts, either full or part time, in our skilled nursing facility located in Redford Twp. Revised pay scale and good benefits. Good orientation offered in Geriatric Nursing. Contact Nursing Director between 9AM-3PM at CAMBRIDGE NURSING HOME, W. 18653 Beech Dale, 255-1010 An Equal Opportunity Employer

EXECUTIVE SECRETARY Blooming Hills, proficient shorthand and typing. Excellent management, benefits, \$16,000, fee paid.

EXECUTIVE SECRETARY Blooming Hills, proficient shorthand and typing. Excellent management, benefits, \$16,000, fee paid.

LEGAL SECRETARIES Full time, salary based on experience. Southfield. Call for appointment. 649-0888

PERSONNEL AT LAW 3040 TOWN CENTER, SUITE 2580 SOUTHFIELD, MICH 48075

SECRETARY We offer a challenging opportunity for competent individual who has at least 5 years secretarial experience and is accustomed to working in a fast-paced environment. The ideal candidate will have typing skills of 80 WPM, shorthand, dictating equipment experience and a strong numerical aptitude. Word processing experience is beneficial.

COOKS & BUSBOYS Full and part time. No experience necessary. Apply in person ORIGINAL PANCAKE HOUSE 19555 W. 10 Mile Rd. (between Southfield & Evergreen)

REAL ESTATE NETWORK Clear-Fron Realty 27492 Five Mile Rd. Livonia 425-7300

DENTAL RECEPTIONIST - experienced with working knowledge of dental insurance, scheduling calls, etc.

RN's, LPN's Positions available on all shifts, either full or part time, in our skilled nursing facility located in Redford Twp. Revised pay scale and good benefits. Good orientation offered in Geriatric Nursing. Contact Nursing Director between 9AM-3PM at CAMBRIDGE NURSING HOME, W. 18653 Beech Dale, 255-1010 An Equal Opportunity Employer

EXECUTIVE SECRETARY Blooming Hills, proficient shorthand and typing. Excellent management, benefits, \$16,000, fee paid.

EXECUTIVE SECRETARY Blooming Hills, proficient shorthand and typing. Excellent management, benefits, \$16,000, fee paid.

LEGAL SECRETARIES Full time, salary based on experience. Southfield. Call for appointment. 649-0888

PERSONNEL AT LAW 3040 TOWN CENTER, SUITE 2580 SOUTHFIELD, MICH 48075

SECRETARY We offer a challenging opportunity for competent individual who has at least 5 years secretarial experience and is accustomed to working in a fast-paced environment. The ideal candidate will have typing skills of 80 WPM, shorthand, dictating equipment experience and a strong numerical aptitude. Word processing experience is beneficial.

COOKS & BUSBOYS Full and part time. No experience necessary. Apply in person ORIGINAL PANCAKE HOUSE 19555 W. 10 Mile Rd. (between Southfield & Evergreen)

REAL ESTATE NETWORK Clear-Fron Realty 27492 Five Mile Rd. Livonia 425-7300

DENTAL RECEPTIONIST - experienced with working knowledge of dental insurance, scheduling calls, etc.

RN's, LPN's Positions available on all shifts, either full or part time, in our skilled nursing facility located in Redford Twp. Revised pay scale and good benefits. Good orientation offered in Geriatric Nursing. Contact Nursing Director between 9AM-3PM at CAMBRIDGE NURSING HOME, W. 18653 Beech Dale, 255-1010 An Equal Opportunity Employer

EXECUTIVE SECRETARY Blooming Hills, proficient shorthand and typing. Excellent management, benefits, \$16,000, fee paid.

EXECUTIVE SECRETARY Blooming Hills, proficient shorthand and typing. Excellent management, benefits, \$16,000, fee paid.

LEGAL SECRETARIES Full time, salary based on experience. Southfield. Call for appointment. 649-0888

PERSONNEL AT LAW 3040 TOWN CENTER, SUITE 2580 SOUTHFIELD, MICH 48075

SECRETARY We offer a challenging opportunity for competent individual who has at least 5 years secretarial experience and is accustomed to working in a fast-paced environment. The ideal candidate will have typing skills of 80 WPM, shorthand, dictating equipment experience and a strong numerical aptitude. Word processing experience is beneficial.

COOKS & BUSBOYS Full and part time. No experience necessary. Apply in person ORIGINAL PANCAKE HOUSE 19555 W. 10 Mile Rd. (between Southfield & Evergreen)

REAL ESTATE NETWORK Clear-Fron Realty 27492 Five Mile Rd. Livonia 425-7300

DENTAL RECEPTIONIST - experienced with working knowledge of dental insurance, scheduling calls, etc.

RN's, LPN's Positions available on all shifts, either full or part time, in our skilled nursing facility located in Redford Twp. Revised pay scale and good benefits. Good orientation offered in Geriatric Nursing. Contact Nursing Director between 9AM-3PM at CAMBRIDGE NURSING HOME, W. 18653 Beech Dale, 255-1010 An Equal Opportunity Employer

EXECUTIVE SECRETARY Blooming Hills, proficient shorthand and typing. Excellent management, benefits, \$16,000, fee paid.

EXECUTIVE SECRETARY Blooming Hills, proficient shorthand and typing. Excellent management, benefits, \$16,000, fee paid.

LEGAL SECRETARIES Full time, salary based on experience. Southfield. Call for appointment. 649-0888

PERSONNEL AT LAW 3040 TOWN CENTER, SUITE 2580 SOUTHFIELD, MICH 48075

SECRETARY We offer a challenging opportunity for competent individual who has at least 5 years secretarial experience and is accustomed to working in a fast-paced environment. The ideal candidate will have typing skills of 80 WPM, shorthand, dictating equipment experience and a strong numerical aptitude. Word processing experience is beneficial.

COOKS & BUSBOYS Full and part time. No experience necessary. Apply in person ORIGINAL PANCAKE HOUSE 19555 W. 10 Mile Rd. (between Southfield & Evergreen)

REAL ESTATE NETWORK Clear-Fron Realty 27492 Five Mile Rd. Livonia 425-7300

DENTAL RECEPTIONIST - experienced with working knowledge of dental insurance, scheduling calls, etc.

RN's, LPN's Positions available on all shifts, either full or part time, in our skilled nursing facility located in Redford Twp. Revised pay scale and good benefits. Good orientation offered in Geriatric Nursing. Contact Nursing Director between 9AM-3PM at CAMBRIDGE NURSING HOME, W. 18653 Beech Dale, 255-1010 An Equal Opportunity Employer

EXECUTIVE SECRETARY Blooming Hills, proficient shorthand and typing. Excellent management, benefits, \$16,000, fee paid.

EXECUTIVE SECRETARY Blooming Hills, proficient shorthand and typing. Excellent management, benefits, \$16,000, fee paid.

LEGAL SECRETARIES Full time, salary based on experience. Southfield. Call for appointment. 649-0888

PERSONNEL AT LAW 3040 TOWN CENTER, SUITE 2580 SOUTHFIELD, MICH 48075

SECRETARY We offer a challenging opportunity for competent individual who has at least 5 years secretarial experience and is accustomed to working in a fast-paced environment. The ideal candidate will have typing skills of 80 WPM, shorthand, dictating equipment experience and a strong numerical aptitude. Word processing experience is beneficial.

COOKS & BUSBOYS Full and part time. No experience necessary. Apply in person ORIGINAL PANCAKE HOUSE 19555 W. 10 Mile Rd. (between Southfield & Evergreen)

REAL ESTATE NETWORK Clear-Fron Realty 27492 Five Mile Rd. Livonia 425-7300

DENTAL RECEPTIONIST - experienced with working knowledge of dental insurance, scheduling calls, etc.

RN's, LPN's Positions available on all shifts, either full or part time, in our skilled nursing facility located in Redford Twp. Revised pay scale and good benefits. Good orientation offered in Geriatric Nursing. Contact Nursing Director between 9AM-3PM at CAMBRIDGE NURSING HOME, W. 18653 Beech Dale, 255-1010 An Equal Opportunity Employer

EXECUTIVE SECRETARY Blooming Hills, proficient shorthand and typing. Excellent management, benefits, \$16,000, fee paid.

EXECUTIVE SECRETARY Blooming Hills, proficient shorthand and typing. Excellent management, benefits, \$16,000, fee paid.

LEGAL SECRETARIES Full time, salary based on experience. Southfield. Call for appointment. 649-0888

PERSONNEL AT LAW 3040 TOWN CENTER, SUITE 2580 SOUTHFIELD, MICH 48075

SECRETARY We offer a challenging opportunity for competent individual who has at least 5 years secretarial experience and is accustomed to working in a fast-paced environment. The ideal candidate will have typing skills of 80 WPM, shorthand, dictating equipment experience and a strong numerical aptitude. Word processing experience is beneficial.

COOKS & BUSBOYS Full and part time. No experience necessary. Apply in person ORIGINAL PANCAKE HOUSE 19555 W. 10 Mile Rd. (between Southfield & Evergreen)

REAL ESTATE NETWORK Clear-Fron Realty 27492 Five Mile Rd. Livonia 425-7300

DENTAL RECEPTIONIST - experienced with working knowledge of dental insurance, scheduling calls, etc.

RN's, LPN's Positions available on all shifts, either full or part time, in our skilled nursing facility located in Redford Twp. Revised pay scale and good benefits. Good orientation offered in Geriatric Nursing. Contact Nursing Director between 9AM-3PM at CAMBRIDGE NURSING HOME, W. 18653 Beech Dale, 255-1010 An Equal Opportunity Employer

EXECUTIVE SECRETARY Blooming Hills, proficient shorthand and typing. Excellent management, benefits, \$16,000, fee paid.

EXECUTIVE SECRETARY Blooming Hills, proficient shorthand and typing. Excellent management, benefits, \$16,000, fee paid.

LEGAL SECRETARIES Full time, salary based on experience. Southfield. Call for appointment. 649-0888

PERSONNEL AT LAW 3040 TOWN CENTER, SUITE 2580 SOUTHFIELD, MICH 48075

SECRETARY We offer a challenging opportunity for competent individual who has at least 5 years secretarial experience and is accustomed to working in a fast-paced environment. The ideal candidate will have typing skills of 80 WPM, shorthand, dictating equipment experience and a strong numerical aptitude. Word processing experience is beneficial.

COOKS & BUSBOYS Full and part time. No experience necessary. Apply in person ORIGINAL PANCAKE HOUSE 19555 W. 10 Mile Rd. (between Southfield & Evergreen)

REAL ESTATE NETWORK Clear-Fron Realty 27492 Five Mile Rd. Livonia 425-7300

DENTAL RECEPTIONIST - experienced with working knowledge of dental insurance, scheduling calls, etc.

RN's, LPN's Positions available on all shifts, either full or part time, in our skilled nursing facility located in Redford Twp. Revised pay scale and good benefits. Good orientation offered in Geriatric Nursing. Contact Nursing Director between 9AM-3PM at CAMBRIDGE NURSING HOME, W. 18653 Beech Dale, 255-1010 An Equal Opportunity Employer

EXECUTIVE SECRETARY Blooming Hills, proficient shorthand and typing. Excellent management, benefits, \$16,000, fee paid.

EXECUTIVE SECRETARY Blooming Hills, proficient shorthand and typing. Excellent management, benefits, \$16,000, fee paid.

LEGAL SECRETARIES Full time, salary based on experience. Southfield. Call for appointment. 649-0888

PERSONNEL AT LAW 3040 TOWN CENTER, SUITE 2580 SOUTHFIELD, MICH 48075

SECRETARY We offer a challenging opportunity for competent individual who has at least 5 years secretarial experience and is accustomed to working in a fast-paced environment. The ideal candidate will have typing skills of 80 WPM, shorthand, dictating equipment experience and a strong numerical aptitude. Word processing experience is beneficial.

COOKS & BUSBOYS Full and part time. No experience necessary. Apply in person ORIGINAL PANCAKE HOUSE 19555 W. 10 Mile Rd. (between Southfield & Evergreen)

REAL ESTATE NETWORK Clear-Fron Realty 27492 Five Mile Rd. Livonia 425-7300

DENTAL RECEPTIONIST - experienced with working knowledge of dental insurance, scheduling calls, etc.

RN's, LPN's Positions available on all shifts, either full or part time, in our skilled nursing facility located in Redford Twp. Revised pay scale and good benefits. Good orientation offered in Geriatric Nursing. Contact Nursing Director between 9AM-3PM at CAMBRIDGE NURSING HOME, W. 18653 Beech Dale, 255-1010 An Equal Opportunity Employer

EXECUTIVE SECRETARY Blooming Hills, proficient shorthand and typing. Excellent management, benefits, \$16,000, fee paid.

EXECUTIVE SECRETARY Blooming Hills, proficient shorthand and typing. Excellent management, benefits, \$16,000, fee paid.

LEGAL SECRETARIES Full time, salary based on experience. Southfield. Call for appointment. 649-0888

PERSONNEL AT LAW 3040 TOWN CENTER, SUITE 2580 SOUTHFIELD, MICH 48075

SECRETARY We offer a challenging opportunity for competent individual who has at least 5 years secretarial experience and is accustomed to working in a fast-paced environment. The ideal candidate will have typing skills of 80 WPM, shorthand, dictating equipment experience and a strong numerical aptitude. Word processing experience is beneficial.

COOKS & BUSBOYS Full and part time. No experience necessary. Apply in person ORIGINAL PANCAKE HOUSE 19555 W. 10 Mile Rd. (between Southfield & Evergreen)

REAL ESTATE NETWORK Clear-Fron Realty 27492 Five Mile Rd. Livonia 425-7300

DENTAL RECEPTIONIST - experienced with working knowledge of dental insurance, scheduling calls, etc.

RN's, LPN's Positions available on all shifts, either full or part time, in our skilled nursing facility located in Redford Twp. Revised pay scale and good benefits. Good orientation offered in Geriatric Nursing. Contact Nursing Director between 9AM-3PM at CAMBRIDGE NURSING HOME, W. 18653 Beech Dale, 255-1010 An Equal Opportunity Employer

506 Help Wanted Sales EXPERIENCED AGENTS Settle in home surroundings, friendly atmosphere. Excellent listings ready for your expert attention. Please call Laverne Eady 624-4711

506 Help Wanted Sales MATURE SALESPERSON - full-time Apply within, any day except Monday, at Kitchen Glamour, 2670 Grand River

506 Help Wanted Sales REAL ESTATE You sell, we process! Commission up to 95% plus \$2,000 bonus at \$15,000. This is NOT a share of the office expense plan, we provide everything including a Dynamic and Respected Name.

506 Help Wanted Sales SHOE SALES Experienced person needed for women shoe salon. Top salary and other benefits. Apply in person. Robeys Shoes, Tel. Twelve Mail, Telegraph at 12 Mile

508 Help Wanted Domestic CLEANING LADY, references, own transportation, 1 1/2 days per week. Bloomfield area. Call 552-2690

512 Situations Wanted Female MOTHER WISHES babysitting, days, own transportation. Merriman/Cherry Hill area. 522-6284

518 Education & Instruction IBM KEYPUNCH Learn Now-Work in Weeks DAY & EVENING CLASSES FREE Placement Assistance

518 Education & Instruction PIANO LESSONS IN YOUR HOME Popular or Classical. All ages. The Association of Music Teachers

520 Secretarial & Business Services TYPING, Neat, Fast, Accurate. Southfield Location Call 568-8176

506 Help Wanted Sales FULL & PART TIME Sales Clerks for Southfield Gift Shop Yankee Doodle, 357-2122

506 Help Wanted Sales FURNITURE SALES PERSON Experienced only Full time. Benefits. Excellent career opportunity. Contact Stewart at Thomas Furniture, 874-4921

SALES CONSULTANT for builder-developer in W. Bloomfield Must have new home sales experience & be willing to work weekends

506 Help Wanted Sales SHOE SALES MATURE PERSON needed for women shoe salon. Top salary and other benefits. Apply in person. Robeys Shoes, Tel. Twelve Mail, Telegraph at 12 Mile

508 Help Wanted Domestic CLEANING LADY, references, own transportation, 1 1/2 days per week. Bloomfield area. Call 552-2690

512 Situations Wanted Female MOTHER WISHES babysitting, days, own transportation. Merriman/Cherry Hill area. 522-6284

518 Education & Instruction IBM KEYPUNCH Learn Now-Work in Weeks DAY & EVENING CLASSES FREE Placement Assistance

518 Education & Instruction PIANO LESSONS IN YOUR HOME Popular or Classical. All ages. The Association of Music Teachers

520 Secretarial & Business Services TYPING, Neat, Fast, Accurate. Southfield Location Call 568-8176

506 Help Wanted Sales FULL & PART TIME Sales Clerks for Southfield Gift Shop Yankee Doodle, 357-2122

506 Help Wanted Sales FURNITURE SALES PERSON Experienced only Full time. Benefits. Excellent career opportunity. Contact Stewart at Thomas Furniture, 874-4921

SALES CONSULTANT for builder-developer in W. Bloomfield Must have new home sales experience & be willing to work weekends

506 Help Wanted Sales SHOE SALES MATURE PERSON needed for women shoe salon. Top salary and other benefits. Apply in person. Robeys Shoes, Tel. Twelve Mail, Telegraph at 12 Mile

508 Help Wanted Domestic CLEANING LADY, references, own transportation, 1 1/2 days per week. Bloomfield area. Call 552-2690

512 Situations Wanted Female MOTHER WISHES babysitting, days, own transportation. Merriman/Cherry Hill area. 522-6284

518 Education & Instruction IBM KEYPUNCH Learn Now-Work in Weeks DAY & EVENING CLASSES FREE Placement Assistance

518 Education & Instruction PIANO LESSONS IN YOUR HOME Popular or Classical. All ages. The Association of Music Teachers

520 Secretarial & Business Services TYPING, Neat, Fast, Accurate. Southfield Location Call 568-8176

INDEPENDENT MFG'S AGENT Be your own boss. Set your own hours. Work even part time. Represent local industrial equipment corporation with over 30 years experience

OPPORTUNITY for experienced salesman to handle industrial accounts in SE Michigan for local agency. Nationally known products include instruments, mixers, waste water equipment

SALES REPRESENTATIVE Good opportunity for College Student. Furniture Sales. Jimmie Rust Furniture, 644-1199

507 Help Wanted Part Time EASTERN HELP WANTED for Fairlane, Northland & Oakland Mills Manager, photographers and helpers needed. Call Jimmie Rust Furniture, 644-1199

510 Help Wanted Couples APARTMENT MANAGER 33 unit building, Farmington Hills. Experience only. References required. Salary, plus apartment. Call Mon-Fri, 318-5820

518 Education & Instruction ALL SUBJECTS & GRADES Taught by certified teachers giving personal instruction in your home. Special help for LD & reading problems

518 Education & Instruction PIANO INSTRUCTIONS Ragtime, popular and classical. Beginner through advanced. Rochester area. Call 373-3829

520 Secretarial & Business Services GENERAL & STATISTICAL TYPING Reasonable rates. Pick up & Delivery. Western Suburbs. 420-2152

520 Secretarial & Business Services HELIUM BALLOON Bouquet Delivery Service. Helium & gram sent anywhere in US. 294-4848

518 Education & Instruction Put a new career on your horizon... National Travel and Airline Careers can train you for an exciting career as a flight attendant

USED CAR SALES PERSON One of the largest Lincoln-Mercury dealerships in the country has limited openings for those interested in a professional sales career

PART TIME TELLERS EXPERIENCE PREFERRED SECURITY BANK OF NOVI 41325 10 MILE RD CALL FOR APPOINTMENT 478-4000

512 Situations Wanted Female ABCARE Specializing in private duty nursing in the Home. Hospital, Nursing Facilities RN's, LPN's, CNA's, AIDES

512 Situations Wanted Female ABCARE Specializing in private duty nursing in the Home. Hospital, Nursing Facilities RN's, LPN's, CNA's, AIDES

518 Education & Instruction ALL SUBJECTS & GRADES Taught by certified teachers giving personal instruction in your home. Special help for LD & reading problems

518 Education & Instruction PIANO INSTRUCTIONS Ragtime, popular and classical. Beginner through advanced. Rochester area. Call 373-3829

520 Secretarial & Business Services GENERAL & STATISTICAL TYPING Reasonable rates. Pick up & Delivery. Western Suburbs. 420-2152

520 Secretarial & Business Services HELIUM BALLOON Bouquet Delivery Service. Helium & gram sent anywhere in US. 294-4848

518 Education & Instruction Put a new career on your horizon... National Travel and Airline Careers can train you for an exciting career as a flight attendant

USED CAR SALES PERSON One of the largest Lincoln-Mercury dealerships in the country has limited openings for those interested in a professional sales career

PART TIME TELLERS EXPERIENCE PREFERRED SECURITY BANK OF NOVI 41325 10 MILE RD CALL FOR APPOINTMENT 478-4000

512 Situations Wanted Female ABCARE Specializing in private duty nursing in the Home. Hospital, Nursing Facilities RN's, LPN's, CNA's, AIDES

512 Situations Wanted Female ABCARE Specializing in private duty nursing in the Home. Hospital, Nursing Facilities RN's, LPN's, CNA's, AIDES

518 Education & Instruction ALL SUBJECTS & GRADES Taught by certified teachers giving personal instruction in your home. Special help for LD & reading problems

518 Education & Instruction PIANO INSTRUCTIONS Ragtime, popular and classical. Beginner through advanced. Rochester area. Call 373-3829

520 Secretarial & Business Services GENERAL & STATISTICAL TYPING Reasonable rates. Pick up & Delivery. Western Suburbs. 420-2152

520 Secretarial & Business Services HELIUM BALLOON Bouquet Delivery Service. Helium & gram sent anywhere in US. 294-4848

Time up your mechanics skills. MoTech auto repair evening classes begin the week of March 23. Register now. Whether you're a working professional or a Do-It-Yourselfer, MoTech can help you sharpen your skills

USED CAR SALES PERSON One of the largest Lincoln-Mercury dealerships in the country has limited openings for those interested in a professional sales career

PART TIME TELLERS EXPERIENCE PREFERRED SECURITY BANK OF NOVI 41325 10 MILE RD CALL FOR APPOINTMENT 478-4000

512 Situations Wanted Female ABCARE Specializing in private duty nursing in the Home. Hospital, Nursing Facilities RN's, LPN's, CNA's, AIDES

512 Situations Wanted Female ABCARE Specializing in private duty nursing in the Home. Hospital, Nursing Facilities RN's, LPN's, CNA's, AIDES

518 Education & Instruction ALL SUBJECTS & GRADES Taught by certified teachers giving personal instruction in your home. Special help for LD & reading problems

518 Education & Instruction PIANO INSTRUCTIONS Ragtime, popular and classical. Beginner through advanced. Rochester area. Call 373-3829

520 Secretarial & Business Services GENERAL & STATISTICAL TYPING Reasonable rates. Pick up & Delivery. Western Suburbs. 420-2152

520 Secretarial & Business Services HELIUM BALLOON Bouquet Delivery Service. Helium & gram sent anywhere in US. 294-4848

Sears' ONE OF MICHIGAN'S LARGEST OUTLET STORES. 10 DAY WAREHOUSE SALE SAVE UP TO 75% OFF SEARS REGULAR PRICES. STOCKROOM OPEN TO THE PUBLIC. *INDICATES NEW, BUT DISCONTINUED ITEMS. NEW ITEMS ARRIVING DAILY. HUNDREDS OF ADDITIONAL ITEMS TOO NUMEROUS TO LIST. 422-5700. BEDDING, LIVING ROOM, DINETTE & DINING ROOM, APPLIANCES, MISCELLANEOUS, BEDROOM, LIVING ROOM.

600 Personals

LOSE WEIGHT WITH ME
Safe, natural method. Guaranteed effective or full refund. 373-2680

604 Announcements

NOTICE OF PUBLIC HEARING
The next regular meeting of the Board of the Southeastern Michigan Transportation Authority will be held on Tuesday, March 17, 1981, at 1:30 PM.

606 Legal Notices

NOTICE OF PUBLIC HEARING
The next regular meeting of the Board of the Southeastern Michigan Transportation Authority will be held on Tuesday, March 17, 1981, at 1:30 PM.

602 Lost & Found

BLOOMFIELD TWP. SHELTER
Lost or Found a pet? Call Monday-Friday 9 AM-3 PM, also nice Pets for Adoption. 420-2070

608 Transportation

RIDE NEEDED 3 nights per week.
from Birmingham to Grand-Ocean Area. Will share expenses. 647-4305

626 Bingo

EACH FRIDAY - 7 PM
MADONNA COLLEGE
SCHOOLCRAFT AT LEVIAN
LIVONIA

607 Attorney Services

ATTORNEYS AT LAW
FIRST CONSULTATION FREE
SAT & EVE APPTS AVAILABLE
D'Avanzo & Meconi
4212 FORD RD., SUITE 101
459-5300

628 Entertainment

A BAND FOR your listening and dancing pleasure. Some Spring dates.
The Sound Merchants 355-0419

700 Auction Sales

ART AUCTION
Friday, March 10, 7PM Preview, 8PM Auction. O.L. Smith School, 23851 Yale, Dearborn (near Telegraph). 373-2469

702 Antiques

MULBERRY HILL ANTIQUES
Will bring a jan cupboard, chimney cupboard, pine table, benches, hooked rug, candles, folk art and lots of small things to the Batoford Inn Antique Show this Sat. & Sun.

701 Collectibles

701 Collectibles
FIRST 5 Hibel Mother's Day plates \$1000 781-4028

702 Antiques

ANNOUNCING THE FIRST
OLDE INN
ANTIQUITY SHOW
at the
DEARBORN INN
MARCH 21 & 22
SAT. 10-9 SUN. 10-5

702 Antiques

ANTIQUE bedroom furniture that was used by Grandmothers. Cherry or oak with carved designs, dresser, vanity, mirror, double bed with headboard & footboard. 373-2469

701 Collectibles

701 Collectibles
FIRST 5 Hibel Mother's Day plates \$1000 781-4028

702 Antiques

ANNOUNCING THE FIRST
OLDE INN
ANTIQUITY SHOW
at the
DEARBORN INN
MARCH 21 & 22
SAT. 10-9 SUN. 10-5

702 Antiques

ANTIQUE bedroom furniture that was used by Grandmothers. Cherry or oak with carved designs, dresser, vanity, mirror, double bed with headboard & footboard. 373-2469

701 Collectibles

701 Collectibles
FIRST 5 Hibel Mother's Day plates \$1000 781-4028

702 Antiques

ANNOUNCING THE FIRST
OLDE INN
ANTIQUITY SHOW
at the
DEARBORN INN
MARCH 21 & 22
SAT. 10-9 SUN. 10-5

702 Antiques

ANTIQUE bedroom furniture that was used by Grandmothers. Cherry or oak with carved designs, dresser, vanity, mirror, double bed with headboard & footboard. 373-2469

701 Collectibles

701 Collectibles
FIRST 5 Hibel Mother's Day plates \$1000 781-4028

702 Antiques

ANNOUNCING THE FIRST
OLDE INN
ANTIQUITY SHOW
at the
DEARBORN INN
MARCH 21 & 22
SAT. 10-9 SUN. 10-5

706 Appliances

RECYCLE FOR CASH
Carbide \$5.75 Up/Lb
Batteries \$3.00 Each
Alum 20-40¢ Per Lb
Also buying Copper, Brass, Lead, Radiators, Nickel, Alloys, Starters, Generators, Stainless Steel, Tool Steel, etc.

706 Appliances

WANTED: Appliances, Furniture, Gas Ranges, Refrigerators, Chests, Dressers, Bedroom Sets, Wringers, Washers, Electric Ranges & Household Pay Cash. KE-5186

706 Household Goods

COCKTAIL TABLE: very dark cherry wood, finest quality \$175. End table \$125. Call 683-2110

706 Household Goods

WANTED: small metal lathe, large jig saw or band saw, home workshop tools \$250. 464-7547

706 Appliances

AIR CONDITIONER: Window less than 1 yr. Emerson Quiet Wind, 22,000 BTUs, \$325. 427-3679 or 957-2944

706 Appliances

WANTED: small metal lathe, large jig saw or band saw, home workshop tools \$250. 464-7547

706 Appliances

WANTED: small metal lathe, large jig saw or band saw, home workshop tools \$250. 464-7547

RED WING TICKET WINNER

Kim Norman
32801 Vermont
Livonia
Please call the promotion department of the Observer & Eccentric by 5 p.m. Friday, March 13, 1981 to claim your 2 free RED WING TICKETS. 591-2300 ext. 244

CONGRATULATIONS!

SAT. APPT. AVAILABLE
FREE 1st CONSULTATION
DIVORCE - uncontested \$150
DIVORCE - contested from \$225
CHILD SUPPORT - modification \$125
WILLS - simple not included \$35

CONGRATULATIONS!

SAT. APPT. AVAILABLE
FREE 1st CONSULTATION
DIVORCE - uncontested \$150
DIVORCE - contested from \$225
CHILD SUPPORT - modification \$125
WILLS - simple not included \$35

CONGRATULATIONS!

SAT. APPT. AVAILABLE
FREE 1st CONSULTATION
DIVORCE - uncontested \$150
DIVORCE - contested from \$225
CHILD SUPPORT - modification \$125
WILLS - simple not included \$35

CONGRATULATIONS!

SAT. APPT. AVAILABLE
FREE 1st CONSULTATION
DIVORCE - uncontested \$150
DIVORCE - contested from \$225
CHILD SUPPORT - modification \$125
WILLS - simple not included \$35

CONGRATULATIONS!

SAT. APPT. AVAILABLE
FREE 1st CONSULTATION
DIVORCE - uncontested \$150
DIVORCE - contested from \$225
CHILD SUPPORT - modification \$125
WILLS - simple not included \$35

CONGRATULATIONS!

SAT. APPT. AVAILABLE
FREE 1st CONSULTATION
DIVORCE - uncontested \$150
DIVORCE - contested from \$225
CHILD SUPPORT - modification \$125
WILLS - simple not included \$35

CONGRATULATIONS!

SAT. APPT. AVAILABLE
FREE 1st CONSULTATION
DIVORCE - uncontested \$150
DIVORCE - contested from \$225
CHILD SUPPORT - modification \$125
WILLS - simple not included \$35

CONGRATULATIONS!

SAT. APPT. AVAILABLE
FREE 1st CONSULTATION
DIVORCE - uncontested \$150
DIVORCE - contested from \$225
CHILD SUPPORT - modification \$125
WILLS - simple not included \$35

CONGRATULATIONS!

SAT. APPT. AVAILABLE
FREE 1st CONSULTATION
DIVORCE - uncontested \$150
DIVORCE - contested from \$225
CHILD SUPPORT - modification \$125
WILLS - simple not included \$35

CONGRATULATIONS!

SAT. APPT. AVAILABLE
FREE 1st CONSULTATION
DIVORCE - uncontested \$150
DIVORCE - contested from \$225
CHILD SUPPORT - modification \$125
WILLS - simple not included \$35

CONGRATULATIONS!

SAT. APPT. AVAILABLE
FREE 1st CONSULTATION
DIVORCE - uncontested \$150
DIVORCE - contested from \$225
CHILD SUPPORT - modification \$125
WILLS - simple not included \$35

CONGRATULATIONS!

SAT. APPT. AVAILABLE
FREE 1st CONSULTATION
DIVORCE - uncontested \$150
DIVORCE - contested from \$225
CHILD SUPPORT - modification \$125
WILLS - simple not included \$35

CONGRATULATIONS!

SAT. APPT. AVAILABLE
FREE 1st CONSULTATION
DIVORCE - uncontested \$150
DIVORCE - contested from \$225
CHILD SUPPORT - modification \$125
WILLS - simple not included \$35

CONGRATULATIONS!

SAT. APPT. AVAILABLE
FREE 1st CONSULTATION
DIVORCE - uncontested \$150
DIVORCE - contested from \$225
CHILD SUPPORT - modification \$125
WILLS - simple not included \$35

CONGRATULATIONS!

SAT. APPT. AVAILABLE
FREE 1st CONSULTATION
DIVORCE - uncontested \$150
DIVORCE - contested from \$225
CHILD SUPPORT - modification \$125
WILLS - simple not included \$35

3 Accounting Services

PERSONAL & BUSINESS
Income tax preparation
Gary L. Figurski, P.C. 522-9110

9 Aluminum Siding

ALUMINUM SIDING & TRIM SALE
From gutters to roofing, shutters complete remodeling.
Licensed & Insured
Heritage Home Improvement
537-0452 532-5668

ALUMINUM SIDING

ALUMINUM SIDING TRIM
All Work Guaranteed
LICENSED BUILDER
Call
EARL WOOD
421-5474

ALUMINUM SIDING

ALUMINUM SIDING
Custom Trim
Gutters, Storm Windows, & Storm Doors. Awning, Porch & Patio Enclosures. Owner Operated. No Salesmen. Write Arriving Guarantee on All Materials & Workmanship. Free Estimates. Licensed & Insured.
MILLS HOME IMPROVEMENT
Call anytime 838-2326

ALUMINUM & VINYL SIDING

ALUMINUM & VINYL SIDING
Trim & Gutters. Frame replacement windows. Storm windows, patios, awnings, enclosures. 30 yrs. exp. Free Est. Father & Sons 453-6485

HUFFMAN'S

HUFFMAN'S
Roofing Siding & Gutters
Canton 439-3329

LEISURE HOMES

LEISURE HOMES
WILL BEAT YOUR BEST PRICE
Siding, trim, gutters, awnings, windows, roofing, vinyl replacement windows. Frank Feidt 525-7677

NORDIC SIDING & ROOFING

NORDIC SIDING & ROOFING
Licensed & Insured
531-8944

SIDING WORK NEEDED

SIDING WORK NEEDED
All types. Free Estimates.
SENTRY CONTRACTORS INC.
478-4444

15 Asphalt

AI'S Asphalt Paving
Has been serving the Tri-county area since 1944. Owner supervision and modern equipment. Guaranteed quality workmanship at reasonable rates. State licensed. Insured.
SEAL COATINGS

24 Basement Waterproofing

24 Basement Waterproofing
ALL WEATHER WATERPROOFING
Walls and Floors Repaired
Free Estimates 464-6926

BASEMENT LEAKS REPAIRED

BASEMENT LEAKS REPAIRED
Drains & Sump pumps repaired
25 YEARS EXPERIENCE
Earl H. Jensen 474-6224

BASEMENT & ROOF LEAK REPAIR

BASEMENT & ROOF LEAK REPAIR
Good work, low prices & Guaranteed. Peter Maati 476-1565

BASEMENT WATERPROOFING

BASEMENT WATERPROOFING
Roof Repair (Hot & Cold)
Caulking & Porches Repaired
Guaranteed 522-1312

BASEMENT WATERPROOFING

BASEMENT WATERPROOFING
Leaks, Repairs, Outside Digging
Licensed, insured. 422-2404

STOP BASEMENT LEAKS

STOP BASEMENT LEAKS
With XYPEX Concrete Waterproofing
Roof Repair (Hot & Cold)
Caulking & Porches Repaired
Guaranteed 522-1312

WATERPROOFING

WATERPROOFING
Guaranteed - Leaks Stopped
All Wall Repair - Free Estimate
Call Joe. 581-5821

27 Brick, Block & Cement

27 Brick, Block & Cement
CHIMNEYS
Repaired or built new. Screened. Cleaned. Roof leaks stopped. GUARANTEED. Ga-7-3981

27 Brick, Block & Cement

27 Brick, Block & Cement
ALL TYPES BRICK & BLOCK WORK
Chimneys-Fireplaces-Porches-Steps-Additions & Cement Work. Free Estimates. Reasonable Prices. 522-7092

27 Brick, Block & Cement

27 Brick, Block & Cement
Brick, Block, Cement work
Foundations, Porches & Tuckpointing
Any job, call anytime. 534-1570

29 Boat Docks

29 Boat Docks
42 in. footings, labor & material, \$7.50 per ft. Including only .80¢ per ft. 8 in. blocks \$1.75 ea., 30 yrs. exp. Licensed contractor #58775. 476-0476

SPRING CLEANUP

SPRING CLEANUP
Debris removed from
Turf & Shrubbery
Spring Fertilizer
Call Dave's Lawn 399-7480

30 Bookkeeping Services

30 Bookkeeping Services
PAYROLL SERVICE
Complete payroll package
\$150 per employee. Call for details. 428-3090

33 Building & Remodeling

33 Building & Remodeling
COMPLETE
REMODELING
By Experienced Licensed Contractor
15 Yrs. Same Business
Specializing In:
ADDITIONS:
Rough In or Completely Finished
Highly Recommended
Home Improvement Loans
Available now at reasonable Rates
For Free Est. & Planning Assistance
CALL 477-7743

CUSTOM WOOD DECKS

CUSTOM WOOD DECKS
Call Ron Causey
336-2248

ADDITIONS & GARAGES

ADDITIONS & GARAGES
Kitchens, complete modernization
CALL UNIVERSAL 422-8492

ADDITIONS MODERNIZATION NEW HOMES

ADDITIONS MODERNIZATION NEW HOMES
Kitchens - Bath - Basement remodeling. We can cover your existing cabinets in woodgrain formica. Licensed & insured. Call 295-2468

33 Building & Remodeling

33 Building & Remodeling
COMPLETE
REMODELING
By Experienced Licensed Contractor
15 Yrs. Same Business
Specializing In:
ADDITIONS:
Rough In or Completely Finished
Highly Recommended
Home Improvement Loans
Available now at reasonable Rates
For Free Est. & Planning Assistance
CALL 477-7743

CUSTOM CARPENTRY

CUSTOM CARPENTRY
SPECIALIZING IN:
CABINET REFINING
BATHS REC ROOMS
NEW CABINETS
CUSTOM COUNTER TOPS
GUARANTEED FREE ESTIMATES
CALL RAY 477-0724

CUSTOM HOMES

CUSTOM HOMES
On Your Lot
MARTY GRAFF'S
CONSTRUCTION CO.
274-8833

DE SANTO HOME IMPROVEMENT CO.

DE SANTO HOME IMPROVEMENT CO.
Bid remodeling specialists. Kitchens, baths, rec rooms, roofing, aluminum siding, gutters. All phases of home improvement. Licensed, insured, rec builder. 20 yrs. experience. Call Vince De Santo for free estimates. 522-1811

IT COSTS NO MORE ...to get

IT COSTS NO MORE ...to get
first class workmanship.
FIRST PLACE WINNER of two National Awards. HAMILTON has been satisfying customers for over 20 years.
You deal directly with the owner. All work guaranteed and competitively priced.
FREE Estimates - Designs - Additions - Kitchens - Porch Enclosures, etc.
HAMILTON BUILDERS
Call 559-5990...24 hrs.

KITCHEN, BATH & Basement remodeling

KITCHEN, BATH & Basement remodeling. We can cover your existing cabinets in woodgrain formica. Licensed & insured. Call 295-2468

KITCHEN REMODELING

KITCHEN REMODELING
Formica Cabinets, Counters
Refacing. Lic. Ins. Walt 476-6991

KITCHENS - BASEMENTS - BATHS

KITCHENS - BASEMENTS - BATHS
100 per hour
Experienced - References
Call Tom 525-3682

LOW COST HOME IMPROVEMENTS

LOW COST HOME IMPROVEMENTS
Re-tiling & Repairs, Gutters, Storm Doors, Baths, Siding, Free Estimates. Prompt service. 538-3666 526-7044

33 Building & Remodeling

33 Building & Remodeling
COMPLETE
REMODELING
By Experienced Licensed Contractor
15 Yrs. Same Business
Specializing In:
ADDITIONS:
Rough In or Completely Finished
Highly Recommended
Home Improvement Loans
Available now at reasonable Rates
For Free Est. & Planning Assistance
CALL 477-7743

CUSTOM CARPENTRY

CUSTOM CARPENTRY
SPECIALIZING IN:
CABINET REFINING
BATHS REC ROOMS
NEW CABINETS
CUSTOM COUNTER TOPS
GUARANTEED FREE ESTIMATES
CALL RAY 477-0724

CUSTOM HOMES

CUSTOM HOMES
On Your Lot
MARTY GRAFF'S
CONSTRUCTION CO.
274-8833

DE SANTO HOME IMPROVEMENT CO.

DE SANTO HOME IMPROVEMENT CO.
Bid remodeling specialists. Kitchens, baths, rec rooms, roofing, aluminum siding, gutters. All phases of home improvement. Licensed, insured, rec builder. 20 yrs. experience. Call Vince De Santo for free estimates. 522-1811

IT COSTS NO MORE ...to get

IT COSTS NO MORE ...to get
first class workmanship.
FIRST PLACE WINNER of two National Awards. HAMILTON has been satisfying customers for over 20 years.
You deal directly with the owner. All work guaranteed and competitively priced.
FREE Estimates - Designs - Additions - Kitchens - Porch Enclosures, etc.
HAMILTON BUILDERS
Call 559-5990...24 hrs.

KITCHEN, BATH & Basement remodeling

KITCHEN, BATH & Basement remodeling. We can cover your existing cabinets in woodgrain formica. Licensed & insured. Call 295-2468

KITCHEN REMODELING

KITCHEN REMODELING
Formica Cabinets, Counters
Refacing. Lic. Ins. Walt 476-6991

KITCHENS - BASEMENTS - BATHS

KITCHENS - BASEMENTS - BATHS
100 per hour
Experienced - References
Call Tom 525-3682

LOW COST HOME IMPROVEMENTS

LOW COST HOME IMPROVEMENTS
Re-tiling & Repairs, Gutters, Storm Doors, Baths, Siding, Free Estimates. Prompt service. 538-3666 526-7044

33 Building & Remodeling

33 Building & Remodeling
COMPLETE
REMODELING
By Experienced Licensed Contractor
15 Yrs. Same Business
Specializing In:
ADDITIONS:
Rough In or Completely Finished
Highly Recommended
Home Improvement Loans
Available now at reasonable Rates
For Free Est. & Planning Assistance
CALL 477-7743

CUSTOM CARPENTRY

CUSTOM CARPENTRY
SPECIALIZING IN:
CABINET REFINING
BATHS REC ROOMS
NEW CABINETS
CUSTOM COUNTER TOPS
GUARANTEED FREE ESTIMATES
CALL RAY 477-0724

CUSTOM HOMES

CUSTOM HOMES
On Your Lot
MARTY GRAFF'S
CONSTRUCTION CO.
274-8833

DE SANTO HOME IMPROVEMENT CO.

DE SANTO HOME IMPROVEMENT CO.
Bid remodeling specialists. Kitchens, baths, rec rooms, roofing, aluminum siding, gutters. All phases of home improvement. Licensed, insured, rec builder. 20 yrs. experience. Call Vince De Santo for free estimates. 522-1811

IT COSTS NO MORE ...to get

IT COSTS NO MORE ...to get
first class workmanship.
FIRST PLACE WINNER of two National Awards. HAMILTON has been satisfying customers for over 20 years.
You deal directly with the owner. All work guaranteed and competitively priced.
FREE Estimates - Designs - Additions - Kitchens - Porch Enclosures, etc.
HAMILTON BUILDERS
Call 559-5990...24 hrs.

KITCHEN, BATH & Basement remodeling

KITCHEN, BATH & Basement remodeling. We can cover your existing cabinets in woodgrain formica. Licensed & insured. Call 295-2468

KITCHEN REMODELING

KITCHEN REMODELING
Formica Cabinets, Counters
Refacing. Lic. Ins. Walt 476-6991

KITCHENS - BASEMENTS - BATHS

KITCHENS - BASEMENTS - BATHS
100 per hour
Experienced - References
Call Tom 525-3682

LOW COST HOME IMPROVEMENTS

LOW COST HOME IMPROVEMENTS
Re-tiling & Repairs, Gutters, Storm Doors, Baths, Siding, Free Estimates. Prompt service. 538-3666 526-7044

39 Carpentry

39 Carpentry
H & H MODERNIZATION
RESIDENTIAL & COMMERCIAL
"Additions/Garages/Porches
"Basement/Finished Decks
"Store Fronts/Homes
All Phases of Carpentry Work
Licensed & Free Estimates
535-8336 533-9176

KITCHEN SPECIALIST

KITCHEN SPECIALIST
Refacing or New Cabinets
Stretching, patching and rewalling
Install Dishwashers 728-7910

LOW PRICE REPAIRS</

*Classified
Came
Through!*



*Classified
Came
Through!*



*Classified
Came
Through!*

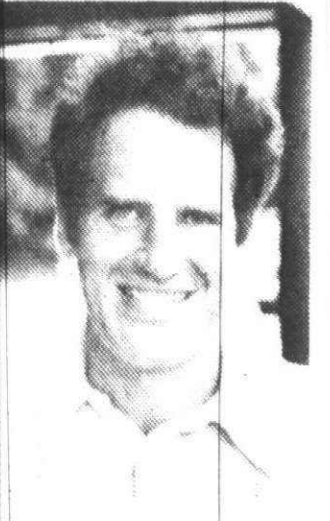

*Classified
Came
Through!*



*Classified
Came
Through!*

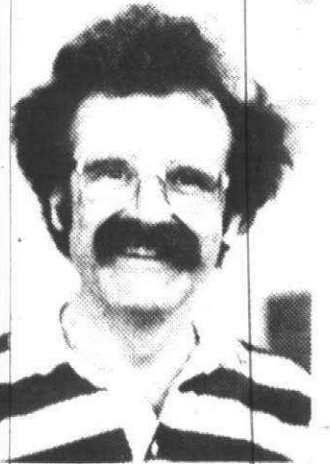

**DON'T
READ THIS PAGE
IF YOU PLACED ONE
OF THE
MORE THAN
190,000
PRIVATE HOMEOWNER
OBSERVER & ECCENTRIC
CLASSIFIED ADS
PUBLISHED
LAST
YEAR.**

It's not you we want to talk to. Chances are your ad got results and you probably placed more than one when you found out how easy it is to put extra dollars into your budget through our Classified section.

You're already convinced that classified ads are a great way to sell things you don't need or can't afford to keep. And if you're a classified seller, you're probably a classified buyer. Because you know that some real bargains can be found when you eliminate the "middle man". You're already an active member of our Classified Club.

So, it's not you we want to talk to. We want to talk to all the people who haven't discovered what fun it is to make money with our classified ads.

Maybe you could help us tell them.

Observer & Eccentric
**classified
ads**

**One call does it all!
Dial Direct 644-1070 in Oakland County • 591-0900 in
Wayne County
852-3222 in Rochester/Avon Twp.**

711 Misc. For Sale Wayne County

25% OFF NAUTILUS VENT FANS 25% OFF RANGE HOODS 15% OFF DELTA FAUCETS... 711 Misc. For Sale Wayne County

720 Farm Produce

MUSHROOM COMPOST Great for gardens and shrubs. Dump truck loads delivered. 720 Farm Produce

726 Musical Instruments

WURLITZER WAREHOUSE New & Used Pianos & Organs 12811 Capitol Ave. Oak Park 545-7414 726 Musical Instruments

738 Household Pets

GERMAN SHORTHAIR Pointer, female, AKC, champion background, excellent hunter, sacrifice 591-0136 738 Household Pets

814 Campers & Motorhomes

APACHE 1978 Ramada, very good condition. Refrigerator, furnace & other extras. \$3100. 76-7133 814 Campers & Motorhomes

821 Junk Cars Wanted

Junk Cars - Trucks Late model wrecks WE TOW AMERICAN AUTO WRECKERS, INC. 268-1090 toll free 821 Junk Cars Wanted

824 Sports & Imported Cars

BMW 77 530A, S/R, cassette, leather 87,495 78 2.1, 3.3 ton. From \$9,500 824 Sports & Imported Cars

824 Sports & Imported Cars

1980 FIAT DEMO SALE SPIDER CONVERTIBLE Leather interior, power windows, AM-FM stereo, 5 speed, fuel injection, 1600 cc. 824 Sports & Imported Cars

860 Chevrolet

ARE YOU WORKING? Credit Applications - No Problem! MATICK CHEVROLET 14001 Telegraph at Jefferson (I-96) 531-7100 860 Chevrolet

721 Flowers & Plants

BRIGHTEN Home or office with blooming plants, delivered regularly & reasonably. Down to earth 546-5470 721 Flowers & Plants

722 Hobbies

BASEBALL CARDS, 1600, 50's & early 60's, \$250 or best offer. Call before 8pm 689-9330 722 Hobbies

726 Musical Instruments

WURLITZER WAREHOUSE New & Used Pianos & Organs 12811 Capitol Ave. Oak Park 545-7414 726 Musical Instruments

738 Household Pets

GERMAN SHORTHAIR Pointer, female, AKC, champion background, excellent hunter, sacrifice 591-0136 738 Household Pets

814 Campers & Motorhomes

APACHE 1978 Ramada, very good condition. Refrigerator, furnace & other extras. \$3100. 76-7133 814 Campers & Motorhomes

821 Junk Cars Wanted

Junk Cars - Trucks Late model wrecks WE TOW AMERICAN AUTO WRECKERS, INC. 268-1090 toll free 821 Junk Cars Wanted

824 Sports & Imported Cars

BMW 77 530A, S/R, cassette, leather 87,495 78 2.1, 3.3 ton. From \$9,500 824 Sports & Imported Cars

824 Sports & Imported Cars

1980 FIAT DEMO SALE SPIDER CONVERTIBLE Leather interior, power windows, AM-FM stereo, 5 speed, fuel injection, 1600 cc. 824 Sports & Imported Cars

860 Chevrolet

ARE YOU WORKING? Credit Applications - No Problem! MATICK CHEVROLET 14001 Telegraph at Jefferson (I-96) 531-7100 860 Chevrolet

721 Flowers & Plants

BRIGHTEN Home or office with blooming plants, delivered regularly & reasonably. Down to earth 546-5470 721 Flowers & Plants

722 Hobbies

BASEBALL CARDS, 1600, 50's & early 60's, \$250 or best offer. Call before 8pm 689-9330 722 Hobbies

726 Musical Instruments

WURLITZER WAREHOUSE New & Used Pianos & Organs 12811 Capitol Ave. Oak Park 545-7414 726 Musical Instruments

738 Household Pets

GERMAN SHORTHAIR Pointer, female, AKC, champion background, excellent hunter, sacrifice 591-0136 738 Household Pets

814 Campers & Motorhomes

APACHE 1978 Ramada, very good condition. Refrigerator, furnace & other extras. \$3100. 76-7133 814 Campers & Motorhomes

821 Junk Cars Wanted

Junk Cars - Trucks Late model wrecks WE TOW AMERICAN AUTO WRECKERS, INC. 268-1090 toll free 821 Junk Cars Wanted

824 Sports & Imported Cars

BMW 77 530A, S/R, cassette, leather 87,495 78 2.1, 3.3 ton. From \$9,500 824 Sports & Imported Cars

824 Sports & Imported Cars

1980 FIAT DEMO SALE SPIDER CONVERTIBLE Leather interior, power windows, AM-FM stereo, 5 speed, fuel injection, 1600 cc. 824 Sports & Imported Cars

860 Chevrolet

ARE YOU WORKING? Credit Applications - No Problem! MATICK CHEVROLET 14001 Telegraph at Jefferson (I-96) 531-7100 860 Chevrolet

721 Flowers & Plants

BRIGHTEN Home or office with blooming plants, delivered regularly & reasonably. Down to earth 546-5470 721 Flowers & Plants

722 Hobbies

BASEBALL CARDS, 1600, 50's & early 60's, \$250 or best offer. Call before 8pm 689-9330 722 Hobbies

726 Musical Instruments

WURLITZER WAREHOUSE New & Used Pianos & Organs 12811 Capitol Ave. Oak Park 545-7414 726 Musical Instruments

738 Household Pets

GERMAN SHORTHAIR Pointer, female, AKC, champion background, excellent hunter, sacrifice 591-0136 738 Household Pets

814 Campers & Motorhomes

APACHE 1978 Ramada, very good condition. Refrigerator, furnace & other extras. \$3100. 76-7133 814 Campers & Motorhomes

821 Junk Cars Wanted

Junk Cars - Trucks Late model wrecks WE TOW AMERICAN AUTO WRECKERS, INC. 268-1090 toll free 821 Junk Cars Wanted

824 Sports & Imported Cars

BMW 77 530A, S/R, cassette, leather 87,495 78 2.1, 3.3 ton. From \$9,500 824 Sports & Imported Cars

824 Sports & Imported Cars

1980 FIAT DEMO SALE SPIDER CONVERTIBLE Leather interior, power windows, AM-FM stereo, 5 speed, fuel injection, 1600 cc. 824 Sports & Imported Cars

860 Chevrolet

ARE YOU WORKING? Credit Applications - No Problem! MATICK CHEVROLET 14001 Telegraph at Jefferson (I-96) 531-7100 860 Chevrolet

720 Farm Produce

MUSHROOM COMPOST Great for gardens and shrubs. Dump truck loads delivered. 720 Farm Produce

721 Flowers & Plants

BRIGHTEN Home or office with blooming plants, delivered regularly & reasonably. Down to earth 546-5470 721 Flowers & Plants

722 Hobbies

BASEBALL CARDS, 1600, 50's & early 60's, \$250 or best offer. Call before 8pm 689-9330 722 Hobbies

726 Musical Instruments

WURLITZER WAREHOUSE New & Used Pianos & Organs 12811 Capitol Ave. Oak Park 545-7414 726 Musical Instruments

738 Household Pets

GERMAN SHORTHAIR Pointer, female, AKC, champion background, excellent hunter, sacrifice 591-0136 738 Household Pets

814 Campers & Motorhomes

APACHE 1978 Ramada, very good condition. Refrigerator, furnace & other extras. \$3100. 76-7133 814 Campers & Motorhomes

821 Junk Cars Wanted

Junk Cars - Trucks Late model wrecks WE TOW AMERICAN AUTO WRECKERS, INC. 268-1090 toll free 821 Junk Cars Wanted

824 Sports & Imported Cars

BMW 77 530A, S/R, cassette, leather 87,495 78 2.1, 3.3 ton. From \$9,500 824 Sports & Imported Cars

824 Sports & Imported Cars

1980 FIAT DEMO SALE SPIDER CONVERTIBLE Leather interior, power windows, AM-FM stereo, 5 speed, fuel injection, 1600 cc. 824 Sports & Imported Cars

720 Farm Produce

MUSHROOM COMPOST Great for gardens and shrubs. Dump truck loads delivered. 720 Farm Produce

721 Flowers & Plants

BRIGHTEN Home or office with blooming plants, delivered regularly & reasonably. Down to earth 546-5470 721 Flowers & Plants

722 Hobbies

BASEBALL CARDS, 1600, 50's & early 60's, \$250 or best offer. Call before 8pm 689-9330 722 Hobbies

726 Musical Instruments

WURLITZER WAREHOUSE New & Used Pianos & Organs 12811 Capitol Ave. Oak Park 545-7414 726 Musical Instruments

738 Household Pets

GERMAN SHORTHAIR Pointer, female, AKC, champion background, excellent hunter, sacrifice 591-0136 738 Household Pets

814 Campers & Motorhomes

APACHE 1978 Ramada, very good condition. Refrigerator, furnace & other extras. \$3100. 76-7133 814 Campers & Motorhomes

821 Junk Cars Wanted

Junk Cars - Trucks Late model wrecks WE TOW AMERICAN AUTO WRECKERS, INC. 268-1090 toll free 821 Junk Cars Wanted

824 Sports & Imported Cars

BMW 77 530A, S/R, cassette, leather 87,495 78 2.1, 3.3 ton. From \$9,500 824 Sports & Imported Cars

824 Sports & Imported Cars

1980 FIAT DEMO SALE SPIDER CONVERTIBLE Leather interior, power windows, AM-FM stereo, 5 speed, fuel injection, 1600 cc. 824 Sports & Imported Cars

860 Chevrolet
MONTE CARLO 1979, air, light blue metallic, only 30,000 miles. \$5,995

LOU LaRICHE CHEVROLET
Plymouth Rd - Just West of I-275
453-4600

MONZA 1978, 2x2, original owner, 30,000 miles, 4 cylinder, maintained garage, automatic, power steering \$2,250

MONZA 1980 hatchback, 4 cylinder, automatic, power steering, air, 5000 miles, under warranty, rebranded, \$5200 or best offer. After 5pm 522-5968

MONZA 1980 Hatch, 37 MPG, 4 cylinder, 4 speed, loaded, air, AM-FM, \$4,375, 855-9257, 575-5965

MONZA 1980, 4 cylinder, 4 speed, air, cloth interior, gauge package, power steering \$4,600 455-3018

NOVA 1973 Hatchback, red, new tires, low miles, power steering, automatic, \$500 or best offer 446-8729

NOVA 1973 307 V-8 automatic, power steering, brakes, AM-FM, air, regular gas, 60,000 miles, 8875 348-0742

NOVA 1974, Hatchback, 2 door, automatic, good transportation \$695

MATICK CHEVROLET
14001 Telegraph at Jelliffe (1-96)
53 1-7 100

860 Chevrolet
NOVA 1974, 6 cylinder, good condition \$800 or best offer. 476-3035

NOVA 1977, 2 door, V8, 302, air, power steering & brakes, radials, 46,000 miles, good condition, reliable. \$2700 624-5695

NOVA 1978, 350 cu.in. power steering, brakes, air, am-fm, rear window defogger. 459-4011

VEGA 1974, GT, air, am-fm, clean, good condition, \$750 firm. 722-5518

VEGA 1974 HATCHBACK, automatic, red, black interior. \$485. Tyne Sales. 455-5564

1977 CHEVETTE
2 door, 4 cylinder, automatic, \$2,395. We take trade & arrange financing.
Roger Peck Chev.
Farmington
474-6723

862 Chrysler
CORDOBA 1977, got it all, including new steel belted, great car. Priced to sell quickly. 355-1800, 851-8120

CORDOBA 1978, 28,000 miles, vinyl, power steering/brakes/windows, rear defrost, undercoat, cruise, stereo, tilt, \$3,500 464-6510

HORIZON 1978, 4 door, 4 speed, hatchback, power steering, am-fm, rustproof, deluxe interior \$3650. 463-4521

862 Chrysler
LE BARON 1977, automatic, air, only 18,000 miles, super clean. \$3,388

LOU LaRICHE CHEVROLET
Plymouth Rd - Just West of I-275
453-4600

LE BARON 1979, 4 door, air, power steering & brakes, AM-FM, rear defrost. Good winter starter. \$3,950. 661-1734

NEWPORT 1973, good condition, air, power, \$650 477-9215

864 Dodge
ASPEN 1977, \$2,800, 41,000 miles, power brakes & steering, new tires, brakes & exhaust system. Excellent condition. 349-3389

CHARGER 1973, Automatic, air, power steering, brakes. Runs well. \$500 or best offer 373-2469

CHARGER 1974, air, 318 engine, 70,000 miles, new brakes, tires & shocks, body very good. \$1,250 474-7969

CHARGER 1974, 318 automatic, power steering, brakes, air, 15,000 miles, like new condition. \$2,100 357-1113

COLT 1981, Brand new. Reasonable. 474-3008

DART 1971, 2 door, air, power brakes, steering, low miles. 334-1409

DART 1978, power steering, brakes, AM-FM, clean interior, good condition. \$1,890 851-0281

DART 1976, Special Edition, power steering & brakes, air, 8 cylinder automatic, 2 door, clean. \$1,250 474-7969

DIPLOMAT 1977, 4 door, automatic, power steering & brakes, air, rear defog, \$2,500 476-5412

DIPLOMAT, 1978, early bird gets the deal, original owner, (wife's car), good, clean. \$3250, 464-9285 or 533-1813

MAGNUM 1978, GT Air, T-tops, much more. Very sharp & clean. \$3,900, will deal. 358-0812

OMNI 1978, Automatic, air, amfm stereo, luggage rack, new tires, 2 tone paint. \$3,650 373-3469

OMNI 1980, power steering, automatic, air, \$550 375-1351

OMNI 1980, Excellent condition, 4 door, loaded, 9000 miles, \$5800 or best offer. \$1,500 After 6PM 476-4822

COLT 1977, air, conditioning, stereo, good condition 685-9314

866 Ford
CREDIT PROBLEM NO PROBLEM! Call Mr. Small 421-1376

ELITE 1975, excellent condition, have been offered \$1,100. Wholesale. Must have \$1,300. Air, power steering, brakes, AM radio. 354-2286

ELITE 1976, low mileage, 31,000 miles, air, undercoating, power steering. \$1,900. Call after 6pm 455-0838

FAIRMONT 1978 Futura, low mileage, excellent condition, power steering & brakes, air, fm stereo, vinyl roof, rear window defogger, asking \$3,495. After 5pm 569-8466

FAIRLANE, 1969, 4 door, good running condition, \$325. 427-2977

FAIRMONT 1978 Wagon, 6 cylinder, automatic, air, power steering, brakes, am-fm, 19,000 miles, excellent condition. \$3,900 553-0586

FAIRMONT 1979 wagon, Low mileage, excellent condition, am-fm stereo. After 6pm. 538-8860

FAIRMONT 1979 Futura, air, automatic, am-fm. Many extras. 18,700 miles. \$4,400 or best offer. 652-0692

FAIRMONT 1979, Squire Wagon. Air, AM-FM, cruise, low miles. Great Condition. Only \$4,595. O'Hara Datsun/35455 Plymouth Rd. 425-3311

FIESTAS, 1978-79, 5- to choose from. Priced from \$3,395 421-1376

FORD 1978, Country Squire Wagon. 10 passenger, 8 cyl., automatic, power steering & brakes, excellent condition. \$2,995. JACK DEMMER FORD 721-6560

FORD 1978, LTD II, 8 cyl., automatic, power steering & brakes, cruise, dove grey. One owner. \$3,195. Bill Brown Ford, 35000 Plymouth Rd. at Wayne Rd. 421-7000

FORD 1979 Pinto Wagon. 4 cyl., automatic, power steering & brakes, 32,000 miles. \$3,795. Bill Brown Ford, 35000 Plymouth Rd. at Wayne Rd. 421-7000

866 Ford
FIESTA 1979, sports package, air, sun roof, many extras. 237-1003, 437-5278

GALAXIE 500, 1966, 2 door, power steering & brakes, low miles, good rubber \$200 356-0647

GALAXIE 500, 1973, amfm 8 track stereo, air, new brakes, new exhaust, power steering & brakes. \$500 261-2405

GRANADA, 1975, power steering/brakes, air, 80,000 miles, good condition. \$3,200 Call. 422-1099

GRANADA 1975, 4 door, Ghia, 6 cylinder, sbck, power steering, air, good condition, 80,000 miles, \$1,200 474-2633

GRANADA, 1978, very clean, 4 door, automatic, air, amfm stereo, power steering & brakes, 2 tone green, vinyl roof, rustproofed, economical 6 cylinder. \$2,400. After 6pm. 626-4810

GRANADA, 1979, ESS auto, 6 cyl., stick-overdrive, loaded, rustproofed, 25,000 miles, \$4,900 474-2599

GRANADA 1979, 2 door Ghia, 6 cylinder, 4 speed with overdrive, 30,500 miles, asking \$3,800. 261-7466

GRANADA, 1979, 6 cylinder, 4 door, power steering, brakes, air, AM-FM, low miles, 1 owner. \$4,900 642-5073

GRAND TORINO, 1973, 4 door, auto, automatic, loaded, rustproofed, 26,000 miles. Power steering & brakes, air, automatic, cruise. \$4650 or best offer. After 5 PM. 474-3952

GRAND TORINO 1972, wagon, \$400, 60,000 miles, dependable transportation. Clean, like new interior, body good, some rust. Snow tires. 348-6415

GRAN TORINO 1974 Brougham, automatic 302, power steering & brakes, air, stereo, vinyl top, new paint, wire Mags, extra wheel set. Excellent condition. \$1,900 or offer. 453-2956

GRENADA 1976, 38,000 miles, rust proofed, fm stereo, air, extra clean. 538-8547

LTD 1974, 2 door, Power steering & brakes, air, AM-FM, rear speaker & window defroster, low battery, good tires, 2 remote mirrors. Very clean inside. \$500 535-9439

866 Ford
LTD Brougham, 1968, V-8 302, ziebart, very clean. New muffler system, tires, brakes, \$575

LTD II, 1978, air, power steering, brakes, am-fm tape, Firestone 721 steel belted radials, 36,000 miles, \$7,990. Call after 5pm. 729-8465

LTD 1971, air, power steering/brakes, regular gas, good condition. \$300. Call. 642-9310

LTD, 1974 Brougham, automatic 8 power, factory air, 46,000 miles, real clean. Call John. 273-5548

LTD 1978, fantastic buy \$2,688. 459-3924

LOU LaRICHE CHEVROLET
Plymouth Rd - Just West of I-275
453-4600

LTD 1978 Landau, air, amfm stereo, cruise, all power, new tires & brakes, very good condition. Best offer \$2500. Call. 427-9839

LTD 1978, loaded, excellent condition, low mileage. Days \$43,3422. Evenings & Weekends 689-8863

LTD 1979, Landau, 4 door, beautiful light green & dark green, vinyl top, 26,000 miles. Power steering & brakes, air, automatic, cruise. \$4650 or best offer. After 5 PM. 474-3952

MACH I 1973, air, automatic, AM-FM, power steering, brakes, 57,800 miles, very good condition, \$3,150 722-7281

MACH I 1978, Power steering, brakes, stereo, rear defog, excellent condition. \$3,500 459-6452

MUSTANG, 1977, stereo, 4 cylinder, power steering/brakes, rustproof, low miles, good condition 585-1180

MUSTANG 1978 Ghia, V-6, power steering, brakes, air, automatic, stereo, \$3,800 After 6PM 649-3697

MUSTANG 1978 hatchback, power steering, brakes, am-fm stereo, rear defrost, rust proofed, under 22,000 miles. \$3,700 553-9427

MUSTANG 1978 2 + 2 3 door, T roof, AM-FM, rear defogger, excellent condition. 981-0713

866 Ford
MAVERICK 1970, \$300. Runs great, good on gas. 459-3924

MUSTANG 1978 2 door, 4 cylinder, automatic, power steering & brakes, stereo, 38,000 miles. \$3,200 offer. 553-9331

MUSTANG 1979, automatic, power steering, am-fm, rear defog, rustproofed, 16,000 miles. \$4,200 643-4834

MUSTANG 1979 Ghia, 2 door, 4 cylinder, 4 speed, air, power, am-fm, rustproofed. \$4585. After 6pm. 729-8465

MUSTANG 1979 Ghia, 3 door, 6 cylinder, power steering, brakes automatic, am-fm cassette, moon roof, rear window defroster, rustproofed, 1 owner. \$5,000 425-8635

MUSTANG, 1979, Stereo, air, sunroof, velour mt. low miles, power steering, brakes A-1, loaded \$4,490 398-0008

MUSTANG 1979, 3 door, air, power steering, brakes, am-fm, rear window defogger. \$3,800 453-9828

MAVERICK 1975, excellent condition, loaded. \$1,900 or best offer. After 6PM. Call. 427-9839

MAVERICK 1975, 6 cyl. automatic, only 35,000 miles. Excellent condition. North Bros. 421-1376

MAVERICK 1977, 2 door, 6 cylinder, automatic, air, power steering, low miles, excellent. \$2,900 689-8269

MAVERICK 1977, automatic, 45,000 miles, \$2,100. Call after 7PM or week ends. 645-9041

MAVERICK 1977, 4 door, 6 cylinder, power steering, air, tinted glass. Excellent condition. \$2,800 348-6219

MAVERICK 1977, 6 cyl. automatic, power steering & brakes, 41,000 miles. \$2,595. Bill Brown Ford, 35000 Plymouth Rd. at Wayne Rd. 421-7000

MUSTANG II 1974, 4 cylinder, 2300 cc, 40,000 miles, transmission 4 speed, German made engine. Best offer. 336-4703

MUSTANG II 1974, 4 cylinder, automatic, power steering, am-fm, rebuilt engine, transmission & brakes, 41,000 miles. Clean no rust. \$1,375 453-4026

MUSTANG II 1976, V-6 4 speed, radials, am-fm stereo, (lastback 25 hwj, 20 city. \$2,350 After 6pm. 533-0570

MUSTANG II 1976, Ghia, 4 cylinder, stick, power steering, power brakes, air, AM-FM stereo with cassette tape & CB radio, bright red with white vinyl top. Good MPG. \$2,395 459-9659

MUSTANG 1965 convertible, restored. \$4,500 464-0552

MUSTANG 1969, 6 cylinder, 200 cu in. Call Saturday or after 425-2537

MUSTANG 1971 Fastback, 351 Cleveland V-8, air, 75,000 miles. \$300 offer. Call Lauren. 474-8411 or 626-2823

PINTO 1971, new battery & alternator. Good mileage. \$300 525-9707

MUSTANG 1976 Fastback, automatic, power steering, rally sport wheels. Beautiful metallic blue finish, looks and runs like the day it left the factory. 1 Yr Limited Warranty. Open Saturday. 35545 Michigan Ave. West, Wayne 455-6449

AUTOLAND
728-3100

PINTO 1979, 2 door, automatic, power steering, power brakes, rear defog, AM radio. 397-0760

PINTO 1973, Wagon, 4 cylinder, 4 speed, excellent transportation. Some rust. Good MPG. \$625 565-9476

PINTO 1975-1979, ROUND UP SALE: 8 to choose from. 421-1376

PINTO 1976, 3 door, 4 cyl. auto, air, power steering, brakes, am-fm, 20 MPG, 50,000 miles. \$2,000. After 6pm. North Bros. 455-6449

PINTO 1976, 3 door, 4 cyl. auto, air, power steering, brakes, am-fm, 20 MPG, 50,000 miles. \$2,000. After 6pm. MFC, 50,000 miles. \$2,000. After 6pm. 565-6449

PINTO 1979, Runabout, automatic, power steering extra sharp & only \$3,885. #B1306A. 425-3036

AVIS FORD
Telegraph at 12 Mile
354-3100

PINTO 1979, 3 door, 4 cylinder, automatic, radio, heater, white wall radials, clean. \$2,995 422-8237

PINTO 1980, 4 cyl. automatic, power steering, tinted glass, 13,000 miles. \$3,995. JACK DEMMER FORD 721-6560

T-BIRD 1978, Diamond jubilee edition, fully loaded. \$4,200. After 5pm. 852-3610

T-BIRD 1978, Town Landau, loaded, 18,000 miles. \$4,150 453-3760

T-BIRD 1980, under warranty, fully loaded, rustproof. Less than 25,000 miles. \$7200. Call after 6 PM. 425-3760

THUNDERBIRD 1977, air, stereo, wire wheel covers, sharp, only \$2,295. AutoSense Computer Checked. Hines Park Lincoln Mercury. 425-3036

THUNDERBIRD 1978, Town Landau, full power, moon roof, \$4,795. AutoSense Computer Checked. Hines Park Lincoln Mercury. 425-3036

THUNDERBIRD 1980, air, stereo, low miles, choose from 2. AutoSense Computer Checked. Hines Park Lincoln Mercury. 425-3036

TORINO 1970 Wagon for parts. Shaker scoop & hood, Cobra grill, 351C engine, wire rims. All for \$200. 425-1178

TORINO 1974, power steering, brakes, air, cruise good, body sharp, 58,000 miles. Must see! \$1,500 offer. 421-1795

TRANSPORATION SPECIALS: 8 to choose from, priced from \$295 to \$895. North Bros. 421-1376

SAVE AT SELLERS

GRAND RIVER 10 MILE

Hurry For Your GM Factory REBATES

UP TO \$700 BACK

ON CERTAIN MODELS

Large In-Stock Selection or Order Yours by Thursday, March 19, 1981

OPEN Monday & Thursday til 9 P.M.

38000 Grand River AT 10 MILE ROAD 478-8000

BOB SELLERS

PONTIAC

500 CADILLACS

READY TO GO!

YOU'RE CLOSER THAN YOU THINK!

TEST PRICE A CADILLAC TODAY!

Don Massey Cadillac

YOUR CARING, SERVICING, SELLING MASTER DEALER

40475 ANN ARBOR RD. AT I-275 PLYMOUTH 453-7500

ART MORAN ITALIAN SERVICE COUPON

In introducing our new Fiat Service Department, we are offering....

INTRODUCTORY OFFER!

10% OFF

ON ANY FIAT REPAIRS

NOW THRU APRIL 15th, 1981

(1) Coupon Per Customer

FIAT SERVICE AND SALES

ART MORAN ITALIAN LTD.

29300 Telegraph, N. of 12 Mile 353-9102

VALUABLE COUPON

SAVE SAVE SAVE

DO IT WITH ONE OF OUR QUALITY DOUBLE CHECKED USED CARS

1976 CUTLASS SUPREME Loaded, 41,000 miles. Showroom condition. Must see. \$2488	1976 MONARCH 2 door, 34,000 miles, like new. Sale Priced. \$2189
1978 REGAL Triple black, loaded. Excellent condition. Sale Priced. \$4788	1978 OLDS CUTLASS SUPREME Air, stereo, road wheels. Excellent condition. Sale Priced at \$4889
1975 REGAL 2 door, automatic, air. Excellent condition. \$1988	1978 COUGAR XR-7 Loaded, low miles. Sale Priced. \$3488

Ask about the works - 12 months or 20,000 miles mechanical repair protection for used car buyers

ARMSTRONG

Bulck-Opel - 525-0900
30550 PLYMOUTH RD., LIVONIA (between Middlebelt & Merriman)

ATTENTION

PUBLIC NOTICE

LEO CALHOUN FORD HAS ACCESS TO

OVER 200 150

BRAND NEW 1980 FRONT WHEEL DRIVE FORD FIESTAS*

ALL ELIGIBLE FOR

\$400

CASH REBATE

ONLY AT LEO CALHOUN FORD

ALL FORD MOTOR COMPANY EMPLOYEES WELCOME

*** All orders must be in by 3 P.M. March 31st, 1981. *This offer good while supply lasts**

1982 EXP NOW ON DISPLAY

A, X, & Z PLAN ORDERS WELCOME

LEO CALHOUN

41001 PLYMOUTH ROAD PLYMOUTH 453-1100

WHERE CUSTOMERS BRING THEIR FRIENDS

Ford

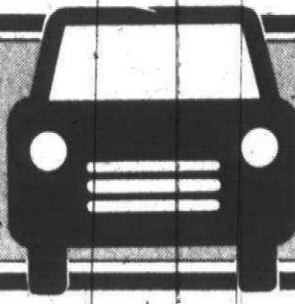

AUTOMOTIVE

866 Ford

MUSTANG 1981, 4 cylinder, automatic, dark brown metallic, carnal interior, poly guarded, under 2000 miles, perfect condition. Sacrifice \$6000 Anytime 345-6415

ZEPHYR, 1979, air, 4 door, power steering & brakes, fm stereo, rear window defroster. \$4300 325-1437

870 Jeeps & Other 4-Wheel Drives

BLAZER 1976 Cheyenne, excellent condition, loaded, see to appreciate, make offer. 851-3246

BLAZER 1976, 4 wheel drive, Like new 49,000 actual miles. \$2,095. Tyne Sales 455-5566

BRONCO, 1978, 4 wheel drive, automatic, real low mileage \$4,495

MATICK CHEVROLET 14001 Telegraph at Jefferies (1-96) 531-7100

CHEVY 1978, 1/2 ton pick up, 4 wheel drive, Silverado package, dual tanks, new radiats, am-fm cassette. \$14000 or best offer. 537-2724

CHEVY 1979, Luv, 11,000 miles, Am/FM cassette, liner. \$5,250 851-6773

DODGE Ram Charger, 1978, 318 engine, Uses regular gas, customized, must see \$4,800 528-3102

FORD 1975, F250, full time 4 wheel drive, automatic, power brakes & steering, part or whole \$1900 689-1806

FORD, 1979, F150 4 x 4, dual tanks, aluminum cap, \$4,700 or make offer. Call 522-0368

FORD 1979 F150 truck, 4 wheel, automatic, built-in CB, AM-FM stereo, rust proofed, Low mileage \$5000 534-3549

GMC JIMMY 1978, fully equipped, clean, never run off road or for plowing, 18,000 miles \$5,000 851-4488

JEEP CJ7 1976, Am/FM 8 track, CB, 74 dis, good condition. \$2,950. After 5:30PM. 360-1799

JEEP 1978 CJ5 Renegade, 6 cylinder, 3 speed, Lvs interior, power steering, am-fm cassette. CB \$4100 421-6674

JEEP 1978 J-20 Pick up, 4 wheel drive, cap, excellent condition, must sell, best offer. 538-8466

JEEP 1979 Cherokee, 2 door, 19,000 miles, rustproofed bits of extras \$5500 525-7761

JEEP 1979 CJ7 golden eagle, hardtop, 6 cylinder, automatic, quadra trac, extras \$5900 Excellent. Call Barb 9:30pm 827-4244 After 6pm 227-5464

JEEP 1979 Wagoneer (Cherokee Chief) Loaded, automatic, tilt, cruise, air, stereo, luggage rack, 20,000 miles, excellent condition. Off lease special \$4,788. Armstrong Buick Leasing, Livonia 522-0900

JEEP 1980, CJ-7, 4 speed, power steering, HARDTOP, tilt wheel, much more \$6,495 O'Hara Datsun, 35855 Plymouth Rd 425-3311

RAM CHARGER, 1979, 4 wheel drive, 2 tone, power steering, automatic, am/fm, rustproof, under 10,000 miles, CB included, \$4,995 522-0919

SURPLUS JEEP Value \$3,196 - Sold for \$44 Call 312-742-1143, Ext 1326 - for information on how to purchase bargains like this

872 Lincoln
LINCOLN 1979 towne car, low mileage, show room condition. Loaded. 673-2037

MARK V, 1979, Diamond Jubilee, gold, fully loaded including passenger 6-way seat, vanity mirrors, tilt, Quad Stereo. Call weekdays 9AM-5PM. 644-4477

NICE SELECTION OF 1977-1980 Lincoln Towne Cars, Marks & Versailles, Autotune Computer Checked, Hines Park Lincoln-Mercury 425-3036

872 Lincoln

1980 LINCOLN TOWN SEDAN Loaded, 10,000 miles, velour interior. SAVE \$, SAVE \$, SAVE \$

BOB BORST LINCOLN-MERCURY (TROY MOTOR MALL) 643-6600

874 Mercury

BOBCAT 1978, 2 door wagon, V6, power brakes, steering, Am-fm, good condition, rear defroster. \$2600 539-2367

CAPRI 1974, 6 cylinder, automatic, rear defroster, stereo, new tires, 1 owner. \$1,500 474-8917

BOBCAT 1978, 4 speed, excellent condition, extras, \$3,500 422-7973

CAPRI, 1979 Sport Model, 4 cylinder, 4 speed, power steering & brakes, AM-FM, rear defrost. \$4200 474-2599

CAPRI 1979, 6 cylinder, automatic, console, stereo, air, defrost, power steering-brakes, rustproofed. 422-4661

COUGAR, 1977 XR7 351 V-8, power steering, brakes, windows, seat, am-fm 8 track stereo, tilt wheel, new brakes. Black exterior, burgandy interior. Excellent condition. 61,000 miles. \$2,395. 349-3361

COUGAR 1978 XR-7, loaded, stereo, etc. Excellent condition. \$3,880. 476-8852

GRAND MARQUIS 1978, 2 door, excellent condition, loaded. 425-8851

874 Mercury

GRAND MARQUIS 1979, triple antique cream, excellent condition, loaded, good MPG, must see \$5100 or best offer. Must sell. After 6pm. 349-8056

MARQUIS 1977, 4 door, power steering and brakes, air, 33,000 miles, very clean, must sell. \$2,700. 478-6053

MARQUIS 1977 4 door, Air, automatic. Power steering, brakes, locks, antenna. Cruise, tilt wheel, remote trunk opening, new pipes & shocks, rear defrost, stereo, undercoat, vinyl roof, 35,000 miles. \$2,800. 422-3342

MONARCH 1976 Gha, 4 door automatic, loaded, \$2,000. 459-1969

MONARCH 1980 4 door, power steering, brakes, air conditioning, automatic am/fm stereo, 10,000 miles. \$5900 455-4553

874 Mercury

GRAND MARQUIS 1978, All power, air, 4 door. Excellent condition, low mileage, stereo. \$3500. 879-0240

MERCURY 1973 Continental Custom, fully loaded, new exhaust, radiator & water pump, recent engine repair, \$400. Call between 9-5 531-0111

MONTGO, 1971, MX, power steering, brakes, vinyl top, 28,000 miles. Excellent condition. \$900 or offer. 362-3429

MONTGO 1973 351CJ, 4 speed, Hurst shifter, power steering, air, am-fm stereo, cruise, good condition. \$995. 422-5181

874 Mercury

MONARCH, 1980, 4 door, 6 cylinder, automatic, air, am/fm, other options \$5,775 474-3370

MONTEREY, 1973, 4 door, power steering/brakes, auto, air. Call Saturday or after. 425-3537

MONTEREY 1969, California car, very good condition, \$600 or offer. 671-2199

GLDS, 1975, Cutlass, 2 door, automatic, one owner. \$2,495

MATICK CHEVROLET 14001 Telegraph at Jefferies (1-96) 531-7100

874 Mercury

MONTAGO 1974, no rust, good condition, auto, power steering, brakes, \$850. After 5pm 397-3027

ZEPHYR 1978, stick shift, 42,000 miles, AM-FM stereo tape, \$2800 or best offer. Weekdays 8-4 835-0930

ZEPHYR, 1978, Villager Wagon Air, stereo, extra clean, \$4,195. Autotune Computer Checked, Hines Park Lincoln-Mercury 425-3036

ZEPHYR, 1980, 2 door, 6 cyl., automatic, air, 7,000 miles, \$5,395. Autotune Computer Checked, Hines Park Lincoln-Mercury 425-3036

the time is NOW! GET IN ON THE REBATE RUSH

FACTORY OFFICIAL CARS
Choose from 10 All makes and models
SAVE UP TO \$2000

1981 GRAND PRIX
AIR CONDITIONED Steel belts, whitewalls, custom bells, rear defogger, tinted glass, sport mirrors, AM/FM stereo, custom wheel covers, body molding, pin stripe, demo. Stock #B0064
SALE \$8115
REBATE \$700
YOU PAY \$7415

1981 FIREBIRD
AIR CONDITIONED Automatic, white side walls, cruise, rear defogger, stereo and much more. Stock #221.
SALE \$8407
REBATE \$700
YOU PAY \$7700

1981 PHOENIX
4 cylinder, 5 door hatchback, cloth interior, power steering, removable cargo cover. Stock #309.
SALE \$6727
REBATE \$500
YOU PAY \$6227

SUNBIRDS 14 READY FOR IMMEDIATE DELIVERY

1981 TRANS AM TURBO SPECIAL EDITION DAYTONA 500 PACE CAR NOW ON DISPLAY

BOB JEANNOTTE PONTIAC 300 CARS IN STOCK
"THE AWARD WINNING DEALER"
14949 SHELTON RD. - PLYMOUTH - JUST N. OF M-14 X-WAY
DETROIT PLYMOUTH AREA 963-7192 • 453-2500
OUT-OF-TOWN CALLS ACCEPTED - OPEN MON. & THURS. TIL 9 P.M.

IT'S YOUR MOVE! WE'VE MADE OURS!

REBATES

FACTORY INCENTIVE MONEY WILL BE PASSED ALONG TO YOU FROM US!

BUY NOW AND GET A REBATE CHECK FROM FORD UP TO \$1769⁰⁰

FORD A-PLAN & HOURLY EMPLOYEES INCLUDED

OPEN MONDAY & THURSDAY 'TIL 9 P.M.

Hines Park **CALL 453-2424**

LINCOLN-MERCURY 40601 ANN ARBOR RD. - PLYMOUTH (AT THE I-275 INTERCHANGE)

Town & Country Dodge

474-6668

SEE THE GOOD GUYS For The Best Deals In Town - For Example -

- UNDER \$2000 ● 9 To Choose From
- UNDER \$3000 ● 18 to Choose From
- UNDER \$4000 ● 43 To Choose From

'76 CUTLASS \$1995
'77 PINTO WAGON \$2995
'79 HORIZON \$3495

9 MILE & GRAND RIVER FARMINGTON • 474-6668

STARK HICKEY WEST SAYS: Now's the time!!

10% Rebate up to \$1157



on Fairmonts - Mustangs - Granadas or thunderbirds purchased out of stock or ordered.

HURRY OFFER ENDS Saturday, March 21st

ORDER YOUR BRAND NEW EXP NOW!!

225 Available To Choose From
NOW'S THE BEST TIME TO BUY! PRICES WILL NEVER BE LOWER.

VALUABLE COUPON

\$100⁰⁰ EXTRA ON YOUR TRADE-IN
Good thru March 21st



STARK HICKEY WEST

24760 W. SEVEN MILE RD. AT GRAND RIVER

Open Monday & Thursday til 9 p.m. **538-6600**

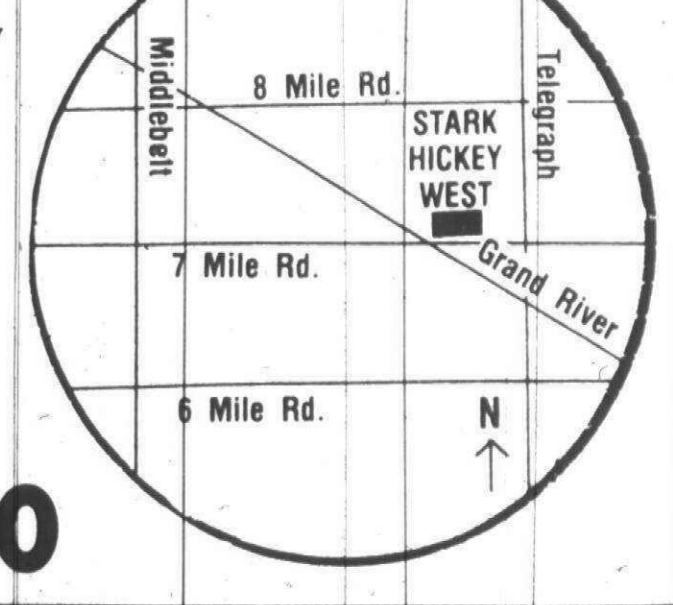

We've been Michigan's #1 FORD DEALER FOR 14 CONSECUTIVE YEARS

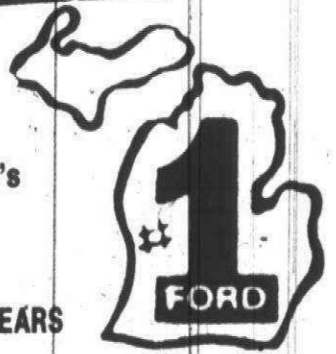

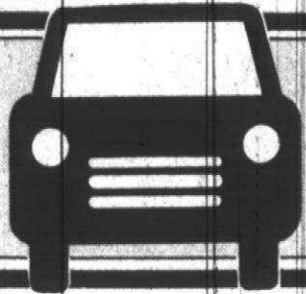

AUTOMOTIVE

874 Mercury

ZEPHYR 1978 Z-7, air, stereo, new brakes. 427-6032
 ZEPHYR 1978, Z-7, power steering, brakes, automatic, stereo, air, wire wheels, 61,000 miles. 455-4215
 ZEPHYR 1979, Sedan, automatic, power steering, air, ideal family car & only \$4,750. #B1333

AVIS FORD

354-3100
 Telegraph at 12 Mile

876 Oldsmobile

CUSTOM CRUISER 1975, full power, air, am-fm stereo 8 track, good condition. 464-0781
 CUSTOM CRUISER 1979, wagon, 9 passenger, full power, tilt & cruise, 29,000 miles. 357-9881
 CUTLASS SUPREME 1979, V8, 23,000 miles, 2 tone body and interior, \$4,500. After 4 PM. 729-6163
 CUTLASS S 1974, power steering, brakes, air, good condition, runs excellent. 349-8459
 CUTLASS 1973 Supreme New paint, rebuilt engine. \$1,500 or best offer. 464-7588
 CUTLASS 1975, 4 door, power brakes, power steering, good condition. 647-0783
 CUTLASS 1976 Am-fm, air, power steering, power brakes, low miles. Excellent condition inside and out. \$2,950 or best. After 5:30. 478-0458
 CUTLASS 1978 Cruiser wagon, tilt, power steering & brakes, stereo, air, cruise control, woodgrain exterior, rustproof, 51,000 miles, good condition. \$2,950. After 5pm. 397-0894
 CUTLASS 1979 Supreme Brougham, 260 V-8, power steering, power brakes, air, tinted glass, rear defroster, intermittent wipers, AM-FM & track. Stereo, cloth seats. 19,000 miles. \$6,000. After 5 PM. 545-2599

876 Oldsmobile

CUTLASS 1980 Brougham, Factory Warranty Loaded, Executive Car. \$6,950. Call. 649-2694
 CUTLASS 1980, Brougham, loaded, executive car, low mileage. \$6,850. 455-7442
 CUTLASS 1980 Cruiser Diesel. Many options. Power door locks, custom interior. Must sell. \$7,950. 855-9218
 CUTLASS 1980 Diesel, Brougham sedan, loaded. 3 year warranty. polyolefin Sony stereo, luxury interior. 14,000 miles. \$7,950. Eves. 428-8113
 CUTLASS 1980 Brougham, 2 door, loaded, 9000 miles. \$7,500. 477-4304
 CUTLASS 1980 Supreme, all power, air, AM-FM stereo, tilt, cruise, many other extras. Must sell. \$6,895. 373-7396

GOOD SELECTION OF NEW & USED OLDSMOBILES

AMCS & TOYOTAS BOB SAKS
 The Complete Dealer
 35300 Grand River Farmington Hills
 478-0500
 LEASE A CUTLASS FOR 35 MONTHS
\$149.82/mo
 \$150.00 pre-payment, 25 mos. option to purchase \$5,100. EPA 21-30
 Key Olds-Datsun 751-6100
 OLDS 88 1978, Royale, fully equipped, 4 door, like new. \$4,095. 375-0980

876 Oldsmobile

REGENCY 1978, 98, 4 door, loaded, exc. for sunroof, 26,000 miles, good condition, must sell. \$4,995. Eves. weekdays. 683-2539, weekdays. 855-3400
 TORONADO 1972, new tires, new battery. Good condition. \$500. 474-7590
 TORONADO 1976, good condition, no rust, power seats, windows, cruise, tilt, stereo, complete new exhaust, \$1,995. 474-8044 or 255-3372
 TORONADO 1980, Diesel Electric Astro roof, loaded, Charcoal firemist oxygen. \$11,300. 739-1259
 TORONADO 1980 Brougham, dove grey, Landau roof, deluxe stereo & 8 track, leather interior, convenience group, power windows & locks, tilt wheel. Executive car. 626-7703

878 Plymouth

ARROW 1977 GT, 2000 cc, 5 speed, radials, AM-FM, stripe pkg., 25 m.p.g., reg gas. \$2,495. 537-0152
 CHAMP 1979 Custom, 1.6 twin stick, am-fm, 38 MPG. \$4,300. 528-1728
 CHAMP 1980 Like new Reasonable. 474-3008
 FURY 1973, dark blue with black vinyl top. Air, good condition. Needs new muffler. \$300 or best offer. 721-5374
 FURY 1975, 2 door, hardtop, automatic, good transportation, \$695. 652-7687
 MATICK CHEVROLET
 14001 Telegraph at Jerries (1-96) 531-7100
 GOLD DUSTER 1973, 2 door, automatic, small V8, power, air, 30,000 miles, like new. No rust. \$1,500. Cash. 538-8813
 HORIZON 1978, 4 speed, 4 cylinder, AM-FM radio, rear window defogger, cloth seat. \$3145, 353-3460 or 841-6087
 HORIZON 1978, 46,000 miles, rack, auto, new tires, stereo, good condition. \$3,000. Call after 5pm. 852-4284
 HORIZON 1979, TC3, automatic, rust proofed, 5MPG, like new. \$4,000 or best offer. 455-7451
 HORIZON 1979, 34 MPG, 4 door, 4 speed, \$3,800. Call Howell after 5 PM. 517-546-3096
 PLYMOUTH 1973, 2 door, excellent condition, power steering, power brakes, automatic transmission, air, AM-FM, \$1,250 or best offer. 9 AM to 5 PM. Mon thru Fri. 358-1050, after 6 PM. 855-1087
 PLYMOUTH 1978, Sapparo, 5 speed, air, stereo, sharp. \$4,495. Autotone Computer (checked) Hipes Park Linn. 425-3036
 VALIANT 1976, brougham, sedan, automatic, small 8, factory air, 36,000 miles, excellent condition. \$1,700. 538-8235

876 Oldsmobile

REGENCY 1978, 98, 4 door, loaded, exc. for sunroof, 26,000 miles, good condition, must sell. \$4,995. Eves. weekdays. 683-2539, weekdays. 855-3400
 TORONADO 1972, new tires, new battery. Good condition. \$500. 474-7590
 TORONADO 1976, good condition, no rust, power seats, windows, cruise, tilt, stereo, complete new exhaust, \$1,995. 474-8044 or 255-3372
 TORONADO 1980, Diesel Electric Astro roof, loaded, Charcoal firemist oxygen. \$11,300. 739-1259
 TORONADO 1980 Brougham, dove grey, Landau roof, deluxe stereo & 8 track, leather interior, convenience group, power windows & locks, tilt wheel. Executive car. 626-7703

878 Plymouth

ARROW 1977 GT, 2000 cc, 5 speed, radials, AM-FM, stripe pkg., 25 m.p.g., reg gas. \$2,495. 537-0152
 CHAMP 1979 Custom, 1.6 twin stick, am-fm, 38 MPG. \$4,300. 528-1728
 CHAMP 1980 Like new Reasonable. 474-3008
 FURY 1973, dark blue with black vinyl top. Air, good condition. Needs new muffler. \$300 or best offer. 721-5374
 FURY 1975, 2 door, hardtop, automatic, good transportation, \$695. 652-7687
 MATICK CHEVROLET
 14001 Telegraph at Jerries (1-96) 531-7100
 GOLD DUSTER 1973, 2 door, automatic, small V8, power, air, 30,000 miles, like new. No rust. \$1,500. Cash. 538-8813
 HORIZON 1978, 4 speed, 4 cylinder, AM-FM radio, rear window defogger, cloth seat. \$3145, 353-3460 or 841-6087
 HORIZON 1978, 46,000 miles, rack, auto, new tires, stereo, good condition. \$3,000. Call after 5pm. 852-4284
 HORIZON 1979, TC3, automatic, rust proofed, 5MPG, like new. \$4,000 or best offer. 455-7451
 HORIZON 1979, 34 MPG, 4 door, 4 speed, \$3,800. Call Howell after 5 PM. 517-546-3096
 PLYMOUTH 1973, 2 door, excellent condition, power steering, power brakes, automatic transmission, air, AM-FM, \$1,250 or best offer. 9 AM to 5 PM. Mon thru Fri. 358-1050, after 6 PM. 855-1087
 PLYMOUTH 1978, Sapparo, 5 speed, air, stereo, sharp. \$4,495. Autotone Computer (checked) Hipes Park Linn. 425-3036
 VALIANT 1976, brougham, sedan, automatic, small 8, factory air, 36,000 miles, excellent condition. \$1,700. 538-8235

878 Plymouth

PLYMOUTH 1978, Horizon, 4 door, automatic, air, showroom condition. North Bros. 421-1376
 VOLARE 1976 Premier wagon, 8 cyl, many options, best price over \$1700. 353-9206
 VOLARE 1976, Premier Wagon Automatic, air, just \$1,495. 421-1376
 VOLARE 1976, Premier wagon, 318 engine, air, stereo, power brakes, \$1,450. 427-6022
 VOLARE 1976 station wagon, power steering, brakes, radio, air, rustproofed, very clean. \$1,800. 538-8547
 VOLARE 1976 station wagon, automatic, 6 cylinder, good condition, \$1,900 or best offer. Call after 2pm. 425-3526
 VOLARE 1976, Wagon, 6 cylinder, air, rustproof, \$1,500. Brighton Area. 229-4094
 VOLARE 1977, 4 door, 6 cylinder, automatic, power steering & brakes, AM-FM, air, excellent condition. 427-0571
 VOLARE 1979 Power steering, brakes, AM-FM radio, air, 25,000 miles. \$3,800. Call 525-9588, after 6 PM. 495-1266

880 Pontiac

ASTRE 1976, 2 door, automatic transmission, clean, good condition. New radials. Radio. \$1,200. 348-9132
 BONNEVILLE BROUGHAM 1979, 2 door, one owner, 3000 miles. \$4,300. Livonia. 591-1905
 BONNEVILLE 1977, power steering, brakes, air, am-fm stereo, beautiful condition. \$4,995. 427-1960
 CATALINA 1973, power steering & brakes, no rust, regular gas, 61,000 miles. \$550. 455-1289
 CATALINA 1975, 2 door, power steering, brakes, am-fm radio, rear speakers, air, vinyl top, triple black, good condition. excellent tires. \$1,295. 525-7783
 FIREBIRD 1972, 350 4 speed, runs good. \$1,000. Call after 6 PM. 422-3644
 FIREBIRD 1976, Exprit, automatic, air, rear defogger, am-fm, asking \$3,000. 588-6503 or 576-0423
 FIREBIRD 1978 Spirit, white, T-top, low mileage, loaded. \$4,900. 425-9038
 GRAND PRIX 1979, LJ, excellent, air, am-fm stereo, power windows & doors, rear defog. sacrifice. 681-2702
 GRAND PRIX 1977, power steering & brakes, air, cruise interior, excellent condition. \$2,900. 348-6017
 GRAND PRIX 1977, excellent MPG, excellent condition, full power, am-fm, air, rustproofed. 476-3033
 GRAND PRIX, 1978, 35,000 miles, loaded, cruise control, air, power windows & locks. \$4,100. 274-2030

880 Pontiac

FIREBIRD 1977, Exprit, power steering & brakes, automatic, air, am-fm stereo, cassette, rustproofed, excellent. \$3,500. 879-8336. 649-2735
 GRAND PRIX 1977, air, am-fm, low mileage, excellent condition. \$2,850 or best offer. 458-7653
 GRAND PRIX 1980, loaded, V6, Executive, low mileage, \$7,200 or best offer. After 5pm. 644-8726
 GRAND PRIX 1980, LJ, loaded, sharp, 2 tone blue, under warranty. \$6,500. Call Cheryl, 492-3229, or 656-1726

1973 LEMANS

2 door, automatic, power steering & brakes, air, \$895. We take trades & arrange financing.
 Roger Peck Chev. Farmington 474-6723
 1979 SUNBIRD
 6 cyl., automatic, power AM-FM stereo, plus more than 20,075 MILES.
 PAT MILLIKEN FORD
 "HOME OF THE SMILING IRISHMAN"
 9600 Telegraph Btwn Plymouth & W. Chicago. 255-5840
 LE MANS 1973, good condition, new battery, tune-up, exhaust system, asking \$800. Ray. 367-4053 or 358-4955
 PHOENIX 1980 Hatchback, red, 20,000 miles, 4 speed, air, power steering, brakes, FM. After 5 PM. 476-7593

880 Pontiac

PONTIAC 1978, Grand Prix Like new, fully equipped. 421-1376
 SAFARI 1972 station wagon, good rubber, runs good, regular gas. \$390. 476-0432
 SUNBIRD 1977 Red white interior compare. 455-5566
 SUNBIRD 1978, 4 cylinder, 4 speed, am-fm stereo, good condition. \$2,400 or offer. 350-2889

SUNBIRD, 1979

Air, rear defogger, custom interior, AM-FM stereo, automatic, very sharp. Only \$4,685.
 JACK CAULEY CHEVROLET ORCHARD LAKE RD. Between I-4 & 15 Mile Hts. 855-9700
 TEMPEST, 1967, 6 cylinder, 230 cu in, low mileage, gas miser, very good condition. \$575. \$38-2191
 TRANS AM, 1977, black, 26,000 miles fully loaded, 6.6 liter engine. \$4,000. 739-4128
 TRANS AM, 1978, automatic, air & a whole lot more. \$4,949. 421-3567
 LOU LaRICHE CHEVROLET Plymouth Rd. - Just West of I-275. 453-4600
 TRANS AM 1979, no T, clean, sharp, few options, \$5,800. Please leave message. 589-3154
 TRANS AM 1980 Turbo, hatch roof, power windows, doors, rear defroster, stereo, am-fm, air, cruise control, loaded, low mileage, excellent condition. \$8,100. After 4:30pm. 595-6837

880 Pontiac

PONTIAC 1978, Grand Prix Like new, fully equipped. 421-1376
 SAFARI 1972 station wagon, good rubber, runs good, regular gas. \$390. 476-0432
 SUNBIRD 1977 Red white interior compare. 455-5566
 SUNBIRD 1978, 4 cylinder, 4 speed, am-fm stereo, good condition. \$2,400 or offer. 350-2889

AUTOLAND

728-3100
 RABBIT 1977, deluxe, 2 door, 4 speed, regular gas, fuel injection, air, rear defroster, am-fm stereo with cassette. Excellent condition. \$3,650 or best offer. Must sell. 477-8373
 RABBIT 1977, 4 door, AM-FM stereo, automatic, regular gas, 27,800 miles. \$4,100. 647-7434 or 644-2387
 RABBIT 1978, excellent condition, low mileage. Best offer. Call Miss Toy between 9:30am-7pm. 421-3567
 RABBIT 1980 Diesel, deluxe perfect condition, under warranty, sunroof, am-fm. \$7,400. 375-1372
 SCIROCCO 1975, like new condition, showroom condition. \$AVE. \$AVE. \$AVE. North Bros. 421-1376

884 Volkswagen

SCIROCCO 1980 AM-FM cassette, air, 5 speed, loaded. Excellent condition. Must see. \$6,895. 535-9078. 362-6453
 SUPER BEETLE 1972, new, clutch, tires, brakes, excellent condition, many options. \$1,200 or best offer. 531-6011
 SUPER BEETLE 1973, excellent condition, AM-FM new seats, no rust, regular gas. 28mpg. \$1,850. 255-3861
 VOLKSWAGEN 1973, Will sell as is or for parts. 349-9409

1978 CHAMPAIGN EDITION RABBIT

Green metallic paint, green velour interior, one year warranty. 10 others in stock.
 TOM SULLIVAN VOLKSWAGEN 25400 W. 8 Mile. 353-6900
 1979 RABBIT DIESEL
 4 door, deluxe silver metallic paint, sunroof, rear wiper. 1 year warranty. \$5,995.
 TOM SULLIVAN VOLKSWAGEN 25400 W. 8 Mile. 353-6900
 '77 RABBIT \$2,295
 '75 DUSTER \$1,695
 '75 BUICK SKYLARK \$1,295
 TOM SULLIVAN VOLKSWAGEN 25400 W. 8 Mile. 353-6900

Bill Cook

The Best Buick Dealer In Farmington Hills

<p>1977 MONTE CARLO Landau, 44,000 miles, 2 tone paint, split seats, tilt, cruise, power locks, stereo. \$3999</p>	<p>1976 MALIBU CLASSIC 2 door, air, automatic, stereo, Rally wheels, full warranty. \$2595</p>
<p>1979 LeBARON MEDALLION 6 cylinder, automatic, stereo, air and more. Immaculate. \$4499</p>	<p>1980 BUICK LeSABRE DIESEL WAGON Loaded with equipment, like new. \$8699</p>
<p>1979-'80 and 1981 RIVIERAS AND TORONADOS 11 in stock. From \$7495</p>	<p>1976 LeSABRE CUSTOM COUPE Automatic, air, 59,000 one owner miles. \$1995</p>
<p>1978 CORVETTE Red, power windows and locks, tilt, cruise, stereo tape, aluminum wheels, 18,000 miles, absolutely perfect!</p>	<p>1978 FORD FAIRMONT 4 door, 15,000 miles, automatic, air. \$3999</p>
<p>1977 CUTLASS SUPREME Air, stereo. This weeks special. \$2999</p>	<p>1978 GRAND LEMANS 4 door, air, wire wheels, automatic. Must See. \$4450</p>

CALL 471-0800
 37911 GRAND RIVER - AT 10 MILE IN FARMINGTON HILLS
 OPEN: Monday & Thursday 'til 9 p.m.

AT MARK CHEVROLET

SAVE AT LEAST \$500 TO \$700

There's a \$500 Cash Bonus on Citation and Chevette... a \$700 Cash Bonus on Camaro and Monte Carlo. You can use the money as your down payment, or get a check directly from Chevrolet. You must take delivery between now and March 19th.

WE HAVE A BIG SELECTION OF ALL MAKES & MODELS

JOHN ROGIN

now general sales manager

- Dodge National Sales Leader for 3 years
- 1980 Cadillac Man of the Year

John invites his 7,000 previous customers to see him for a great deal.

Customer satisfaction is our goal before and after the sale!

33200 MICHIGAN AVE. WAYNE
 Between Merriman and Wayne only minutes from Livonia, I-275, Westland & Garden City & Dearborn
722-9100

CORVETTE & CUSTOM VAN SPECIALISTS

Subaru

ALL MODELS, INCL. 4x4's
STATION WAGON SALE
 12 MONTHS WARRANTY - UNLIMITED MILES
IMMEDIATE DELIVERY
TRIUMPH TR7-----SPITFIRE
\$1,000 REBATE
MGB-JAGUAR XJ6 SERIES III
BOB OWENS IMPORTS
 34043 Ford Rd., Westland
 3 1/2 Miles East of I-275 **722-3910**

REBATE 10% REBATE 10%
STARK HICKEY WEST
 Since 1926
10% REBATE
 up to \$1,157⁰⁰
 Michigan's #1 Ford Dealer For 14 Consecutive Years.
STARK HICKEY WEST
 24760 W. SEVEN MILE RD. AT GRAND RIVER **538-6600**
 REBATE 10% REBATE 10%

NO REBATES NEEDED AD!

'78 VW CONVERTIBLE 29,010 miles, AM/FM stereo, Special Car!	\$6895
'79 MAZDA GLC WAGON Automatic, corona blwn color!	\$4495
'80 MAZDA RX7-GS 5 speed, stereo, sunroof	\$8495
'76 DODGE ASPEN 34,000 miles, 6 cylinder, air, automatic.	\$2695
'74 MAVERICK 66,000 miles, 6 cylinder transportation, power steering, automatic.	\$895
'77 VW SCIROCCO 39,000 miles, automatic, air, cruise, stereo, pearl color!	\$4995
'72 PLYMOUTH SATELLITE 6 cylinder, transportation, power steering, automatic.	\$1295
'77 THUNDERBIRD 42,000 miles, steel wheels, air, stereo, vinyl top, beautiful car.	\$3495
'77 AMC GREMLIN X 4 cylinder, 4 speed, good price, good car.	\$1995
'75 DATSUN B210 4 cylinder, transportation.	\$1195

LIVONIA VW-MAZDA
 34501 Plymouth Rd. 425-5400

WE NEED USED CARS!

- TOP CASH PAID • ANY MAKE
- ANY MODEL • BONUS FOR EXTRA CLEAN CARS AND TRUCKS
- WE PAY OFF NOTES

SEE GARY McQUISTON
CRESTWOOD DODGE
 32850 FORD ROAD GARDEN CITY **421-5700**

NO WAITING HERE!

CHEVY CASH BONUS CARS IN STOCK

CHEVETTES & CITATIONS \$500	CAMAROS & MONTE CARLOS \$700
-----------------------------	------------------------------

CASH BONUS DIRECT FROM GM offer ends march 19, 1981
 OPEN MONDAY & THURSDAY 'TIL 9 PM
 WE FINANCE - SWITCH TO LaRICHE
LOU LaRICHE CHEVROLET
 40875 Plymouth Rd., Plymouth
 Just West of I-275
 Phone 453-4600

RED HOLMAN

DON'T MAKE THE \$100 MISTAKE!

ORDER THE NEW J-2000
PONTIAC
 GM EMPLOYEES WELCOME
 We'll guarantee trade value on delivery (your trade will be worth as much at delivery as it is when you order)
WE STILL HAVE OVER 60 GM REBATE CARS AVAILABLE!
 ORDER THE NEW T-1000
GMC TRUCKS
 1981 Special GMC 1/2 ton Pickup
 8 ft. box, gauges, radial tires.
 #5076-A **\$5495**
 Over 35 others priced to sell NOW including the all new Super Saver

TOYOTA

1981 COROLLA 2 door

Super Special **\$4777** (ONE DAY ONLY)
 Stock #7436A
 Stock #7429A
 Stock #7410A
 BEAT THE SPRING PRICE INCREASE
 Over 60 other Toyota Super Discount Deals Available. Red Holman will beat any other bonafide Toyota deal.

RED HOLMAN

721-1144
 FORD RD. AT WAYNE RD. WESTLAND
 DON'T MAKE THE \$100 MISTAKE

CLASSIFIED REAL ESTATE

Reach 12 communities with 1 call to
591-0900
ONE CALL DOES IT ALL!

312 Livonia

AFFORDABLE FORTIES
Sharp 3 bedroom brick ranch featuring large kitchen with table space, dinette off living room, garage and more for only \$44,900. LAND CONTRACT TERMS.

CENTURY 21
CORNERSTONE 478-4660

ACCENT ON LIVONIA

"GREAT TERMS"
Super land contract terms offered on this immaculate 3 bedroom brick ranch with gorgeous kitchen and table space, large bedrooms, central air, full finished basement and 2 1/2 car garage. Popular area, \$54,900.

\$9,000 ASSUMES
This perfect kept home offering enormous country kitchen with beautiful workmanship, 3 roomy bedrooms, 1 1/2 baths, new carpeting, attached garage and beautiful yard. Asking only \$51,500.

CENTURY 21
TODAY 261-2000

1/4 ACRE
Super buy on this beautiful brick ranch with 3 bedrooms, basement, natural fireplace, 1 1/2 baths, family room, dining room, oversized, 2 car attached garage. Excellent financing! \$73,000.

WOLFE
COMPANY
421-5660

ALL OPEN
SUN 2-5

Land contract 38432 Grandon, So. of Joy, W. of Dix. Three bedrooms, 2 1/2 baths, family room, fireplace, 2 car garage. Only \$68,900. Hurry!

Below market - 38444 Grenada, So. of Lyndon, W. of Dix. Three bedrooms, 1 1/2 baths, family room, fireplace, large fenced yard with shade trees. Only \$65,900. Hurry!

ERA
FIRST FEDERAL
478-3400

AN ACRE
2 bedroom brick bungalow with huge formal dining room, natural fireplace in living room, possible bedroom in unfinished attic, 1 car garage. Huge lot with plenty of shade trees. Close to freeway. Asking \$59,900.

CENTURY 21
TODAY 525-7700

A QUICK SALE
Is needed for this 1 1/2 yr old brick ranch. REDUCED DRastically! Priced \$10,000 below current model, only \$14,200 to assume. Family room, fireplace, center entrance foyer and more. Located in N.W. Livonia.

CALL RAY HURLEY
Red Carpet 522-3500

ATTRACTIVE 3 bedroom brick ranch, 2 baths, sunny kitchen, refinished hardwood floors, air, full basement. Terms \$57,950. By owner. 433-5123.

312 Livonia

BEAUTIFUL COUNTRY setting, 3 bedroom bungalow, fireplace, garage \$54,900. Land Contract terms. Up Investment Realty 531-7382

BRAND NEW
Add your own personal taste to this spacious colonial featuring formal dining, 1st floor utility, large family room with fireplace, 2 1/2 baths, and 2 car attached garage. Ask for:

HELEN KAVANAUGH
CENTURY 21
Gold House Realtors
464-8881

BRICK RANCH - 3 bedrooms, 2 car attached garage, family room with fireplace, 1400 Woodside, 1 block N of Schoeller, 1 block E. of Levan. Open House Sunday 1-5PM. \$84,900. Land Contract terms. 591-3252

BRIGHTEN YOUR FUTURE
With this nice 3 bedroom brick ranch with finished basement, 2 car garage, fenced yard & more for only \$59,900. LAND CONTRACT AVAILABLE.

CENTURY 21
CORNERSTONE 478-4660

BY OWNER - Sacrifice \$60,000 cash to mortgage beautiful brick ranch, 3 bedrooms, 2 1/2 baths, full basement, garage, central air, beautiful porch and patio. After 4 PM, call 591-2198.

BY OWNER Brick 3 bedroom, 1 1/2 bath, aluminum trim ranch, 2 1/2 car garage, patio, finished basement with 4th bedroom or office including kitchen, built ins, central air. \$68,900. 478-5042.

CHARM
Fantastic 3 bedroom brick ranch in prime Livonia features full basement, 2 car garage, on beautiful lot. Kitchen has been remodeled with built in oven, range and dishwasher. Call today \$53,900.

CENTURY 21
TODAY 525-7700

Charming Ranch
Lovely 3 bedroom all brick ranch featuring a lovely finished rec room with bar, garage, plus an excellent location. Only \$66,900.

Century 21
Hartford South 464-6400

CITY FARMER
wanted for this cozy 2 bedroom home on over 1 acre. Featuring dining room, fireplace, garage, more. Asking only \$49,900 with land contract terms available.

CALL 474-2130 NOW
REAL ESTATE STATION

Colonial Charm
Spacious 2000 sq. ft. 4 bedroom 2 1/2 bath brick colonial, formal dining room, family room with natural brick fireplace, tiled basement, 2 car attached garage. \$87,900.

Century 21
Hartford South 464-6400

EXCELLENT STARTER HOME
2 bedrooms, on crawl, new plumbing, kitchen cabinets and lovely ceramic tile in bath. 2 car garage. \$35,000. Call 261-5860.

Thompson-Brown

312 Livonia

COZY AND ELEGANT
Owner leaving state, must sell this beautiful Colonial with huge rooms, 1 1/2 baths, formal dining room, kitchen with built-ins, family room with fireplace, full basement and 2 car attached garage. \$81,900.

Guaranteed Sale
With Reimbursement Plan
WOLFE
COMPANY
421-5660

CUSTOM BUILT
Lovely almost new 3 bedroom brick ranch featuring a huge 21' front driveway, large family room with fireplace, 2 1/2 baths, 2 car attached garage. \$90,000.

Century 21
Hartford South 464-6400

ASSUME 11 1/2% loan for \$13,900. 3 bedroom, 2 1/2 bath brick ranch with aluminum trim, central air, professionally finished basement, 2 1/2 car garage, fenced yard, 2 blocks to school. \$65,000. Before 9 PM. 425-1048.

ASSUME 3 bedroom, 1 1/2 bath brick ranch with attached garage, finished basement, beautiful landscaping. \$64,900. Open House Sunday, 2-5. 14074 Park. 454-0783.

ASSUMPTION
A beautiful location with 4 bedrooms, 2 1/2 baths and this Cape Cod has it all. A nice kitchen with built ins overlooking family room with brick wall fireplace, doorwall to patio overlooking private yard with inground heated pool, full basement with wet bar and 2 car attached garage. \$89,900. Call 454-0783.

WOLFE
COMPANY
421-5660

ASSUMPTION
Transfer forces sale of this immaculate 3 bedroom brick ranch. Newly decorated, like new carpet, hardwood floors, rec room, central air and 2 car garage. Great assumption terms \$53,900.

WOLFE
COMPANY
421-5660

Distressed Sale!
Excellent Assumption! Owner says have to sell 3 bedroom colonial with 2 1/2 baths, family room with fireplace, finished basement. Make him an offer! Mid-Nineties. Call 261-5080.

DOLLAR FOR DOLLAR
You can't beat this nice 3 bedroom, 1 1/2 bath colonial. Excellent floor plan features family room with natural fireplace, basement attached 2 car garage & more for only \$68,900. LAND CONTRACT terms.

Century 21
CORNERSTONE 478-4660

FIRST OFFERING
20 year contract! Sound to good to be true? Or assume 8 1/2%? 3 large bedrooms, brick colonial. Built 1975. Unique floor plan. Family room, fireplace, basement attached garage, central air. \$78,900. Someone will be fortunate they read this ad.

Century 21
CORNERSTONE 478-4660

CALL CONNIE ESPEY
Guaranteed Sale Plan
MAYFAIR 522-8000

312 Livonia

EIGHT IS ENOUGH
Plenty of rooms for a family of 8 or more in this spacious 5 bedroom, 3 bath brick ranch level home. Situated on a half acre wooded lot with family room and fireplace, basement, central air, 3 car attached garage and ideally suited for in-laws. \$129,900.

Guaranteed Sale
With Reimbursement Plan
WOLFE
COMPANY
474-5700

ENGLISH/TUDOR QUAD
(7-0) Out of state move forces sale of best buy in Francavilla Sub. Finished wet bar in cozy family room, stained woodwork and so much more. \$114,900. LAND CONTRACT TERMS.

Century 21
Hartford South 464-6400

VINCENT N. LEE
EXECUTIVE TRANSFER SALES
851-4100

Executive Colonial
Magnificent Nottingham Woods West colonial - features 4 bedrooms, 2 1/2 baths, formal dining, family room with fireplace, 1st floor den/library, 1st floor laundry, central air, tiled basement, common use pool, with large patio, side entrance garage, stained woodwork, crown moldings, neutral decor and papers throughout. Flexible occupancy 11% contract available. Call for details. Open Sun. 2-5. 17523 Edgewood N. of 6 Mile. E. of Wayne. Call 522-6000.

ONE WAY
FANTASTIC FINANCING AVAILABLE

4 bedroom brick ranch with family room and finished basement, oversized garage, 1 1/2 baths, all new kitchen with extras. Your house in time \$69,900. Call Connie Kaper 421-5660.

MAYFAIR 522-8000
FIRST OFFERING
Clean and ready for you and yours. It's a 3 bedroom, brick ranch with a formal dining room, nice kitchen with in-ground pool, full finished basement and garage. \$59,900.

WOLFE
COMPANY
421-5660

KIMBERLY OAKS
Fantastic home in a great area close to Ford Field, the "Y" and ice rink. Custom ranch has 3 bedrooms, formal dining room, family room with fireplace, attached 2 car garage, and beautiful finished basement with bar. \$85,500.

Century 21
Quality Homes, Inc.
274-7200 261-1820

LIVONIA
Only \$23,900 is all it takes to assume the mortgage on this neat ranch in one of Livonia's most popular subs. All the features you are looking for, family room with natural fireplace, full basement and attached garage. 478-1310.

Rymal Symes
LIVONIA Brand new 1,650 ft. ranch on 1/4 acre. \$82,900. L.I. available. Builder will pay taxes for 2 years. Possible trade accepted. 425-5252.

312 Livonia

HAGGERTY - 6 MILE QUAKER TOWN SUB.
BUILDERS CLOSE OUT
10 3/4%
5 YEARS
IMMEDIATE OCCUPANCY
\$79,990-\$89,990

4 left, RANCH 3 bedrooms, 2 1/2 bath, laundry main floor, 2 car garage, dishwasher, family room, fireplace, numerous extras.

Century 21
Boardwalk div. 459-3600

NEEDS WORK - \$4,600 moves in, 3 bedrooms, family room, gas heat, 80 x 136 lot. \$41,900. Farmington/Plymouth Rd area. Century 21, ABC. 425-3230.

KIMBERLY OAKS
REALLY GREAT!
To Live Here!

OPEN SUN. 2-5 PM
33146 Lyndon, just East of Farmington Rd. Two bedroom Custom Ranch, attached garage, beautiful rec room with bar, family room, patio, excellent area, custom features thru-out and only \$69,900. CONVENTIONAL or LAND CONTRACT TERMS.

Real Estate NETWORK
Harrison Moore 427-9030

LIVONIA "BILL WILLIS"
THIS IS REALLY NICE

Brick ranch 3 nice bedrooms, excellent condition, basement finished into recreation room with bar and TV area, aluminum trim, terrace, garage. \$53,900. Richard St. By appointment. **MAYFAIR 522-8000**

LIVONIA - by owner, 3 bedroom ranch, \$51,500 10 1/4% simple assumption. Newly fully fenced lot 142x150. Attached 1 1/2 car garage, screened glass terrace. Many nice features. 535-0119

LAND CONTRACT 9% - 3 bedroom colonial, 1 1/2 plus 1/2 baths, family room, fireplace, full basement, 2 1/2 car attached garage, convenient location. \$13,500 assumes \$425 payments, \$65,900. Buyers only. 351-3520

LAND CONTRACT TERMS
Immaculate 3 bedroom, 2 1/2 bath brick ranch with 23 ft. kitchen, family room with fireplace, plus guest room, finished basement with bar and game room, central air, attached 2 car garage, large lot \$84,900.

Guaranteed Sale
With Reimbursement Plan
WOLFE
COMPANY
421-5660

MR & MRS CLEAN
Live in this super sharp 3 bedroom brick ranch newly listed in Plymouth Twp and featuring a large yard with private patio, 2 car garage, finished basement and much more. A real beauty at \$67,900.

Guaranteed Sale
With Reimbursement Plan
WOLFE
COMPANY
421-5660

OPEN HOUSE Sun. 1-4 31557 Perth 3 bedroom, 1 1/2 baths, brick ranch. 2 car attached garage. Basement. Family room fireplace. Central air. Assumable 10 1/2% \$79,900 522-5162.

312 Livonia

MR. CLEAN
Lives in this 3 bedroom brick ranch with 1 1/2 baths, full finished basement, family room, fireplace, attached garage. Situated on a beautifully landscaped 1/4 acre lot. Call for specifics. Asking \$69,900. Terms available.

Century 21
Boardwalk div. 459-3600

NEW ON MARKET
Brick ranch with aluminum trim offers 3 bedrooms, large living room with dining room, 2 1/2 car garage, beautiful finished basement. 2 1/2 car garage, beautiful fully \$53,900.

Century 21
NADA 477-9800

NOTTINGHAM PARK
Super Nottingham Colonial on treed lot backing to a wooded park area. Maintenance free exterior with 4 bedrooms, 2 1/2 baths, formal dining room, family room extra, fireplace, dress kitchen, first floor laundry, full basement, 3 car attached heated garage and much more. \$119,900.

Guaranteed Sale
With Reimbursement Plan
WOLFE
COMPANY
474-5700

OPEN SUN. 2-5
33221 HEES
ASSUME 9% MORTGAGE
3 bedroom brick ranch, 1 1/2 baths, custom built.

Must See To Appreciate
CAMBRIDGE
459-4620

QUALITY & COMFORT
Livonia's best 4 bedroom brick Colonial with 2 1/2 baths, dining room, family room with fireplace, finished basement, 1st floor laundry, 2 car attached garage. Land Contract Terms you won't believe! \$89,900.

Guaranteed Sale
With Reimbursement Plan
WOLFE
COMPANY
421-5660

Run Don't Walk
Just listed immaculate and freshly decorated 3 bedroom brick ranch, 1 1/2 baths, family room with raised fireplace, full basement, 2 car garage, 2 1/2 car garage, plus much more. Asking \$69,900.

Century 21
Hartford South 261-4200

Century 21
SIMPLE ASSUMPTION

Brick 3 bedroom ranch. 1 1/2 baths, heat ed floor. Garage \$57,900. 525-4200.

Integrity

312 Livonia

Simple Assumption
Sharp and spacious 3 bedroom brick ranch, family room, 2 1/2 baths, super finished basement, central air, 2 car garage. Asking \$71,500. Interest rate 10 1/4%.

Century 21
Hartford South 261-4200

SO APPEALINGLY
decorated you'll immediately feel at home! Beautiful 3 bedroom brick ranch featuring bath off master bedroom, custom fireplace, central air, finished basement & much more for \$95,900. LAND CONTRACT AVAILABLE.

Century 21
CORNERSTONE 478-4660

SPECIAL TERMS
Below market new mortgage or assumption with this sharp 3 bedroom brick ranch home. Featuring a country kitchen, family room with natural fireplace, full basement and 2 car attached garage. \$69,900.

Guaranteed Sale
With Reimbursement Plan
WOLFE
COMPANY
474-5700

NEW HOME for sale 19927 Woodring off 7 Mile Rd. Face brick, 3 bedrooms, 2 1/2 baths, carpeted family room, full basement, gas forced air heat \$67,100. Built by Cornell Homes. Call for information call 477-9340.

SPLENDID 3 BEDROOM ranch home beautifully landscaped in a pretty neighborhood. Special financing arrangements available to provide \$200 month subsidy to help defray high mortgage payments. \$64,900. Call 553-8700.

Thompson-Brown
TERMS & BEAUTY - ASSUME or good BLEND RATE. 3 bedroom brick ranch, ideal location, family room, first floor laundry, large lot. \$82,900.

CORINNE THOMAS
REAL ESTATE ONE
455-7050

"TERMS"
ZERO DOWN Sharp 3 bedroom brick ranch with rec room, central air, and garage, only \$58,900.

Century 21
TODAY 538-2000

THREE BEDROOM brick ranch newly remodeled thru-out, country kitchen, full basement, doorwall to patio, 2 car garage & more. Located near Livonia Mall, asking \$58,900. 8 1/2% assumable mortgage. Open Sun. 1-4. 474-5448 Lamar.

Century 21
Hartford South 261-4200

Towering Trees
overlook this custom home offering 34 ft. family room with fireplace, new country kitchen, inground pool of large patio, 2 car attached garage, and immediate occupancy. \$89,500. Ask for:

HELEN KAVANAUGH
CENTURY 21
Gold House Realtors
464-8881

312 Livonia

WONDERLAND area 3 bedroom brick ranch, 1 1/2 baths, aluminum trim, \$54,900 \$1,000 down, balance on 11 1/2 year land contract. Respond by mail to owner by 25253 Plymouth Rd. Redford, Mich. 48239.

\$10,000 DOWN
On a land contract will move you into this 3 bedroom all brick ranch with basement, garage, freshly painted and new kitchen floor. Call us today \$47,500.

Century 21
TODAY 478-1040

\$4,500 DOWN
Five + Large colonial, 4 spacious bedrooms, 2 1/2 baths, large family room, 2 car attached garage. This home decorated to perfection on a lovely cul-de-sac. It won't last! Only \$89,900.

Century 21
Hartford South 261-4200

10 1/2% FINANCING
Sharp 3 bedroom bungalow in Livonia. Remodeled bath, new carpet, plenty of cupboards in kitchen, newer garage. Assume 9 1/2% mortgage possible. Only \$41,900.

Century 21
TODAY 525-7700

12 3/4% MORTGAGE
LIVONIA
Windridge Village
Models \$89,500
IMMEDIATE OCCUPANCY
One 3 bedroom colonial, one 3 bedroom ranch, both complete with carpeting, drapes, landscaping, sprinkler system, air conditioning, many other extras.

Thompson-Brown
3 BEDROOM BRICK RANCH
large living room, in a nice subdivision with lots of recreational areas close by for the family. Good home for handy man. \$86,900. Call 261-5080.

Thompson-Brown
4 BEDROOM TRIP
on large, treed corner lot. A car attached garage. Lots of creative financing available. Immediate occupancy. \$65,800. Call 261-5080.

Thompson-Brown
5 Mile Newburgh
\$68,900. 8 1/2% mortgage on this 3 bedroom brick ranch. Features family room with fireplace, basement, 4 bedrooms, central air, garage, immediate occupancy. Call 522-6000.

ONE WAY

314 Plymouth-Canton
ASSUME
An 11' land contract on this nicely decorated 3 bedroom tri-level with 2 full baths, family room with natural fireplace, central air, oversized garage and wood deck. A must to see. Call today \$69,500.

Century 21
Boardwalk div. 459-3600

CANTON
Quadr 3 bedroom brick garage, open dining room, family room fireplace, earthtone, 7 1/2% Assume or part Land Contract. \$81,215.

CANTON
By Owner 3 bedroom ranch family room, fireplace, 2 car attached garage, simple assumption 10 1/2% \$44 monthly \$66,900. 837-3593.

312 Livonia

ASSUMPTION
on this super ranch beautifully decorated with a great family room, fireplace, 3 bedrooms, and attached garage \$62,900. Ask for:

AL DUBUQUE
CENTURY 21
Gold House Realtors
420-2100

CANTON
Open House Sun. 2-5. 42275 Eberneck Assumption at \$1 1/2 minimum down payment. This is the one to see! A 3 bedroom colonial with a large family room, a natural fireplace, dining room & 1 1/2 baths. Large bedrooms attached 2 car garage & patio on a large lot. R.R.A. Trident Real Estate 459-4422.

CANTON 1008 HOBOKENE
\$100
Complete move in ready for 4 yrs. Also FHA mortgage terms available. Brand new 4 bedroom 1 1/2 bath colonial all brick. Full basement (carpeted).

GOODMAN-BUILDERS
399-9033

CENTRAL AIR
in this 3 bedroom colonial in Plymouth Twp. Large family room with natural fireplace, recreation room in basement, 1 1/2 baths, 2 car garage, many extras and land contract terms. Asking just \$72,900.

GARLING
Realty
453-4800

Attractive
Contract Terms!
BEAUTIFUL 4 bedroom fully carpeted Crevecoeur colonial with large family room with natural fireplace, mirrored formal dining room, private bathroom and attached 2 car garage. Asking just \$77,900 with great terms! Call 981-2900.

PICTURESQUE! Etreeed park (included in this custom built starter home) on large, treed corner lot. A car attached garage. Lots of creative financing available. Immediate occupancy. \$65,800. Call 261-5080.

THOMPSON-BROWN
SUPER SHARP! 3 bedroom brick ranch with upgraded insulation, large family room with natural fireplace, private dining room, finished basement and attached 2 car garage. Offered at just \$78,000. Call 981-2900.

PICKWICK VILLAGE boasts of this central air conditioned 4 bedroom fully carpeted colonial, large sunroom, sunken family room with natural fireplace, formal dining room, full finished basement, and attached 2 car garage. Offered at just \$78,000. Call 981-2900.

SPACIOUS brick quad level 20' x 20' full baths, 20 ft. family room with natural fireplace, 19 ft. full basement and 2 1/2 car garage. Asking just \$69,900. Call 981-2900.

HANDYMAN NEEDED! to make an offer on this 1 1/2 story suburban sided 3 bedroom home over 1/2 acre of intensive (zoned) property included. Asking just \$21,500 with easy terms. Call 981-2900.

Century 21
Hartford South 261-4200

Real Estate One, INC.
REALTORS

SUMPTER TWP.
Here's your chance to move to the country at a price you can afford. Country living is great in this 3 bedroom tri-level on approximately 1 1/4 acres. You'll love the large country kitchen with double oven and range. Many extras. Owners anxious. Bring all offers. \$64,900. Call 455-

314 Plymouth-Canton
Attractive Home
 PLUS PRICE - Impeccable 4 bedroom brick including central air, spacious family room/fireplace, country kitchen with built-ins, beautiful landscaping, attached 2 car garage, patio, convenient location. Blend mortgage available. Asking \$72,900. Call: 459-5222 or 522-6000.

ONE WAY
 Bay Window Wooded Setting with this professionally decorated North Canton colonial, featuring 4 bedrooms, 2 1/2 baths, formal dining, huge family room with fireplace, central air, full basement, large patio, attached 2 car garage, lovely tree setting and immediate occupancy. Possible 7 1/2% assumption or land contract terms. Asking \$89,900. Call 459-5222 or 464-0800.

ONE WAY
 Blend-Assume-Land Contract
 Delightful, impeccable 2 story home - bright, clean interior with play area in rear commons. Large kitchen, family room/fireplace, 1st floor laundry, attached 2 car garage. Asking only \$73,000. Call 459-5222 or 464-0800.

ONE WAY
 CITY OF PLYMOUTH 4 bedroom Colonial on quiet street, large living room, formal dining room, family room with fireplace & deck, finished rec room in basement, 2 car attached garage with opener. \$88,500. Assumption or blended mortgage possibilities. Open house Sun 2-5 PM. For directions call 453-6004.

314 Plymouth-Canton
 CANTON NORTH - Colonial 3 bedroom, 2 bath ranch with central air. Family room with fireplace, flagstone patio with gas bar-b-que. \$69,900. 455-5369.

Condo - Immaculate OPEN SUN. 1-5
 Care-free living in this original end unit. Maintained beautifully, custom draperies, all appliances, professionally finished 500 sq. ft. basement. Single assumption or land contract terms available. 40598 NEWPORT, Bradbury, S. of Ann Arbor. E. of Haggerty.

Interest Rate To High?
 Sylvia Keough offers homes you "can afford" - 11% financing, 4 bedrooms, 2 1/2 baths, family room, main floor laundry, outstanding CBTM features. \$89,900 - \$92,900. Land contract at 11% or assumption. Please let me show you why you should buy NOW. Thank you Call 261-5090.

SYLVIA KEOUGH, Century 21 Gold House Realtors 459-6000

NEW CONSTRUCTION
 8 1/2% land contract terms are being offered by the builder of these lovely homes. 3 bedroom Ranch at \$75,900 and 4 bedroom Colonials at \$77,900. Come pick your colors today. Call 261-5090.

Thompson-Brown

314 Plymouth-Canton
 LAND CONTRACT
 LOVELY 2 bedroom starter home, completely carpeted, full basement, aluminum siding. After 5 PM. 453-3411.

Exclusive Showing of this convenient 3 bedroom brick ranch can be yours. Pleasing decor with 1 1/2 baths, full basement, fireplace, private patio with rose garden. Ask about possible wrap-around contract at \$68,900. Ask for: BRAD WERNER, Century 21 Gold House Realtors 459-6000

EXTRA LARGE
 rooms. House was enlarged. Beautiful window treatments. Large corner lot, close to clubhouse, pool, and tennis courts. Side entrance garage. 4 bedroom 2 1/2 bath colonial. \$101,500. Ask for: TRENA RUCKER, Century 21 Gold House Realtors 459-6000

314 Plymouth-Canton
 FOUR bedroom colonial (complete), Sunflower Subdivision. Land contract or lease with option to buy. Call 738-5357.

HOLIDAY PARK Sub. By Owner. 4 bedrooms, Cape Cod, 2 full baths, family room with fireplace, Country kitchen. After 6 PM. 459-1492

IN PLYMOUTH MUST SELL
 OPEN SAT. SUN. 3-6 PM. 44888 JOY RD. Large 4 bedroom colonial with family room/fireplace, 2 1/2 baths, attached garage. Simple assumption 7 1/4% or land contract terms 11%. \$69,900. Call: BARB STAHL, Century 21 Gold House Realtors 459-6000

LAND CONTRACT
 Built in '77 and still new! All brick, 3 bedroom, 2 bath ranch with a dream kitchen with built-ins and dinette, family room and 2 car attached garage. \$73,900. Guaranteed Sale With Reimbursement Plan HARRY'S

WOLFE COMPANY 421-5660
 OPEN SATURDAY 2-5 PM. 43283 CANDEWOOD CT. Mayfair Subdivision Super 4 bedroom Colonial.

OPEN SUNDAY 2-5 PM. 46033 ACADEMY - Quail Hollow Estates - A original owner - 4 bedroom Colonial. REALTY WORLD Wm. Decker, Inc. 455-8400

314 Plymouth-Canton
NEED ROOM?
 Move in right away, large family colonial featuring 4 bedrooms with master bath, big country kitchen formal dining room, huge deck off family room, full basement, garage. \$74,500.

Red Carpet
 RICHTER & ASSOC. 522-3500

OPEN SPACES
 Extra large lot affords pleasure and recreation, wood deck for evening quiet, close to major X-ways. 4 bedrooms, 2 1/2 bath colonial with attached garage and partially finished basement. \$79,900. Ask for: BRAD WERNER, Century 21 Gold House Realtors 459-6000

OPEN SUN. 12-2
 160 Hartough. Just reduced 3 bedroom ranch in Plymouth Township. Beautiful finished basement with fireplace, 1 1/2 car attached garage, central air. A must see in condition. \$81,900. 420-0411.

CENTURY 21 CORNERSTONE 437-1010 348-6500

OWNER MUST SELL!
 \$8,000 down on land contract. Sharp 3 bedroom ranch with family room, fireplace, great location. Immediate occupancy. Asking \$65,500. Will look at all offers. Call Betty Greenty for appointment.

EARL KEIM REALTY NORTHVILLE 349-5600

PLYMOUTH TWP. - Lakepointe Sub. 3 bedroom ranch, family room with natural fieldstone fireplace, basement, patio, move-in condition. \$81,900. 420-0411.

314 Plymouth-Canton
 12 1/4% new conventional mortgage available. Brick ranch, 3 bedrooms, family room, fireplace, finished basement with bar, 2 car garage. Mint condition, \$83,900. Must sell. Make offer. Will consider your terms.

NEW WORLD SUMMIT 427-3200

PLYMOUTH TOWNSHIP INFLATION FIGHTER \$89 MOVES VETS IN 3 BEDROOMS
 WALL TO WALL CARPET Based on sales price of \$49,900, mortgage \$89,900 at 13% for 360 months. Payments of \$639. Includes principal, interest, taxes, insurance. Annual percentage rate 14%.

ALTERNATIVE FINANCING TO FIT YOUR BUDGET AVAILABLE
 Newhouse Realty Corp. 277-0816 565-1310

PLYMOUTH TWP.
 This 3 bedroom brick ranch reflects pride of ownership as well as the convenience of being close to shopping and the expressway. ASK FOR MARTHA.

Century 21 HOME CENTER 476-7000

Possible LAND CONTRACT terms on this neat 3 bedroom Aluminum sided home in Plymouth Twp. Detached 2 car garage. Nice lot. 60x145. \$55,900.

LAND CONTRACT terms on 2 bedroom older frame home, basement, large heated garage workshop. Plymouth Twp. \$49,900.

GOOD Plymouth Twp. location with quiet dead-end street is the site of this custom brick Ranch. Attached 2 car garage, 6 1/2 bedrooms, 2 full baths, 3 nice carpeted bedrooms \$101,900. Call for financing details.

NEED 3 bedrooms + basement + 2 car garage? Here is a neat little brick Ranch in Plymouth Twp. For \$58,500. Check with us on how you can own this Great Starter or Retirement home.

WE HAVE several nice 5 and 10 acre parcels located in Superior, Ypsilanti and Northfield Townships. Call for details!

314 Plymouth-Canton
Simple Assumption
 Land contract, VA, FHA, available on this immaculate 3 bedroom brick ranch, open floor plan, and professionally decorated. Only \$74,900. Ask for: NORMA PETERSON, Century 21 Gold House Realtors 459-6000

BETTY VANCE REAL ESTATE ONE 455-7000

VACANT & ANXIOUS
 Bank owned 4 bedroom, 2 1/2 baths brick Colonial. Make an offer on this freshly decorated one featuring formal dining area, family room and fireplace, full basement and 2 car attached garage. Low interest terms \$74,900. Guaranteed Sale With Reimbursement Plan.

HARRY'S WOLFE COMPANY 474-5700

ASSUMPTION OR LAND CONTRACT
 3 bedroom colonial in Windsor Park. \$76,900. \$10,000 down & 11 1/2% land contract or \$24,000 down & 9 1/2% assumption. Call for details. 459-9897. 453-6345

1ST OFFERING
 Gorgeous brick quad in mint condition. Features - 4 spacious bedrooms, 2 1/2 baths, huge family room with fireplace, impressive foyer, formal dining room, country kitchen with built-ins, large patio, professionally landscaped, attached 2 car garage. Land contract terms \$84,900.

CENTURY 21 NADA 477-9800

1ST PRIZE
 In Plymouth Twp., You'll know you have received 1st prize when you own this immaculate 3 bedroom brick ranch with family room/natural fireplace, plush carpeting, central air, finished basement, 2 car attached garage, immediate occupancy and only \$15,000 DOWN ON LAND CONTRACT - GREAT TERMS AND VALUE at \$74,900. Ask for: ED PRINGLEMEIR

CENTURY 21 Gold House Realtors 420-2100

315 Northville-Novl
OPEN SUN. 1-4
 NOVI - TURTLE CREEK
 LAND CONTRACT TERMS offered on this 4 bedroom, 2 1/2 bath COLONIAL with family room and den, built 1979. Immediate occupancy. \$137,900.

LET'S MAKE A DEAL. Bring the family and tour the house & grounds Sunday. 21943 Heatherbrae Way, S. off 9 Mile, E of Meadowbrook. Call John Palmer at 645-9700 for details.

PALMER REALTORS

DESIRABLE MEADOWBROOK HILLS
 Is the location of this 3 bedroom, 2 1/2 bath quality Quad level home. Carefully planned with minimum maintenance, both inside & out. Just relax & enjoy your pool this summer. Land contract terms \$184,000.

Max Brook, Inc. 626-4000

JUST A MILE FROM MEADOWBROOK GOLF COURSE
 An exciting new 4 bedroom Colonial with circular staircase, natural wood work, full basement, large lot. Beautiful family room with brick fireplace. Almost ready for occupancy. A quality home that will stand your closest inspection. \$111,950. Call 553-8200.

Thompson-Brown

Simple Assumption
 (66 bu) \$25,000 will assume at 12% Monthly payment \$750. 4 bedroom colonial, 2 1/2 baths, family room with cathedral ceiling and fireplace built in 1980. Owner transferred. Immediate occupancy. Asking \$99,900.

Century 21
 VINCENT N. LEE, EXECUTIVE TRANSFER SALES 851-4100

433,000 ASSUMES A 9% MORTGAGE.
 On a 4 bedroom, 2 bath Cape Cod in Northville. Novi area. Asking \$53,000. After 5 PM. 348-6465

2824 FANTASTIC garage with roll up door will please him 3 bedroom home and family room will captivate her. Assume 10% mortgage. Harry 54-900

ERA - MASTER ASSOCIATES 478-7550

316 Westland Garden City
 3/4 ACRE
 at end of private drive. Lovely tree fronted property. Outstanding 2 car garage, 3 large bedrooms, large bright kitchen, family room, nicely decorated. New listing. \$44,500. Newburgh. Joy Rd area. Seller will take VA.

BUILDER'S OWN HOME
 1,886 sq. ft. sprawling brick ranch. 2 full baths, full finished basement, full wall fireplace. 4 bedrooms, extra large country kitchen, huge Master bedroom in secluded new addition. Finished basement.

OVERBUILT & UNDERPRICED \$51,900 PRICED FOR QUICK SALE!
 Century 21 Community 522-6410

ASSUME WITH \$10,500
 3 bedroom, attached garage. 2 lots, family room, fireplace. \$33,000. Immediate. \$450/month. Total 12%. Century 21 ABC 425-3250

ASSUME 11%
 Absolutely beautiful 3 bedroom brick ranch with full finished basement, family room with beamed ceiling and natural fireplace. 2 1/2 car garage, kitchen with appliances, patio in rear yard. Priced to sell. \$53,900.

CENTURY 21 TODAY 525-7700

BY OWNER 2 bedroom brick bungalow 2 car garage, nice size lot. Finished basement. Air conditioned. Gas heat. \$46,500. 425-9028

COLONIAL \$5,000 MOVES IN!
 Family room, fireplace, attached 2 car garage, basement. 1 1/2 baths. \$54,900. Century 21 ABC 425-3250

ROBERT BAKE - Realtor
 1005 W. Ann Arbor Trail Plymouth 453-8200



NEVER BEFORE OFFERED! A TREASURE FROM JUST ABOUT ANY POINT OF VIEW. Hidden from all except friends and guests, this superbly conceived Dutch inspired country home is placed on 3 naturally wooded acres in a surprisingly close-in estate area. The sophisticated interior has 4 bedrooms, a noble sized formal dining room, a gracious foyer, 2 1/2 baths, living room with fireplace, a study, a family room with a very attractive fireplace, finished/carpeted recreation room, and side entrance 3 1/2 car garage. EXCEPTIONALLY SPECIAL WITH ITS MANY CUSTOM FEATURES. \$199,000. 453-8200.

FIRST OFFERING! SOPHISTICATED COLORS AND BRICK SELECTIONS create a most favorable first impression upon viewing this 7 year old home. There are 3 bedrooms, 1 1/2 baths, formal dining room, a breakfast area within the kitchen, and 2 1/2 car attached garage with opener. A free form patio and an assumable mortgage further enhance this cheerfully decorated home. \$68,500. 453-8200.

"WALNUT CREEK" OFF N. TERRITORIAL IN PLYMOUTH! An exceedingly popular neighborhood only moments from downtown Plymouth. This welcoming Country Colonial has endless extras of importance... all carefully planned with no thought of ever leaving. An expansive circular drive, richly upgraded carpeting, an extravagant \$4,500 patio/terrace, underground sprinklers, and Central Air. There are eleven rooms. Among them is a pleasing brick foyer, 4 spacious bedrooms, 2 1/2 baths, a formal dining room, a study with a bay window, a family room with wood storage and fireplace, first floor laundry, and side entrance 2 1/2 car garage with opener. A SUPERIOR FAMILY HOME WITH AN ATTRACTIVE ASSUMABLE MORTGAGE. \$169,500. 453-8200.

PLYMOUTH! THIS IMPECCABLY CARED-FOR CENTER ENTRANCE COLONIAL has all the desired features: 4 spacious bedrooms, 2 1/2 baths, formal dining room, an island counter kitchen with all appliances remaining, a study, family room with fireplace, first floor laundry, full basement, and 2 1/2 car attached garage. Its location is very special - backing into a natural wooded commons area. YOU'LL BE FOND OF ITS INTERIOR CONDITION AND COUNTLESS UP-GRADED FEATURES! \$124,900. 453-8200.

NEVER BEFORE OFFERED! FLOWING, UNCONFINED OPENNESS IS EXPRESSED within this "CLIFFORD WRIGHT" designed one story home. A masterly interplay of stained cedar, carefully chosen brick, and cedar shake shingles warmly distinguish the exterior. Over an Acre in the original "BEACON HILL" establishes this location as being without equal... and the expanses of glass and decks take advantage of the lovely, private rear yard. There are 3 generous bedrooms, 2 1/2 baths, a spacious living room with fireplace, and a formal dining room. The 26 ft. long family room encompasses a fieldstone fireplace, a built-in gas barbecue, a 12 ft. ceiling, and a small hospitality kitchen. The main kitchen is fully-equipped. Abundant main floor storage, full basement with a sauna, and oversized 2 1/2 car garage with opener. Central Air, Security system, and underground sprinklers are among the varied extras. FAULTLESSLY MAINTAINED BY THE ORIGINAL OWNERS. \$250,000 WITH LAND CONTRACT TERMS. 453-8200.

NEW ON THE MARKET! CITY OF NORTHVILLE! PERFECTLY GROOMED, THIS LOVELY HOME DESERVES YOUR EARLIEST INTEREST. Spacious rooms and high ceilings provide a wonderful feeling of space. There are 3 bedrooms, 2 1/2 baths, a formal dining room, an efficient kitchen, family room with fireplace, a 20x12 Garden Room, and 2 1/2 car side entrance garage. A newer furnace, roof, and siding are present. A mature setting, skillful interior decorating, and an easily assumable mortgage should stimulate your interest. \$97,900. 453-8200.

NEVER BEFORE OFFERED! PLYMOUTH! A CAREFULLY CHOSEN LOCATION INTENDED TO MINIMIZE OBSTRUCTIVE CAR TRAFFIC, yet moments to both elementary and middle schools. Its exterior reflects immediate pride and quiet good taste. A very special added feature is a separate main floor bedroom with its own private bath... now resulting in a 5 bedroom, 3 1/2 bath center entrance Colonial. There is a formal dining room, a study with floor-to-ceiling bookcases, family room with fireplace, a lovely patio with a brick wall planter, first floor laundry, and 2 1/2 car attached garage. Central Air. YOU'LL LOVE ITS INTERIOR CONDITION! \$129,500. 453-8200.

PLYMOUTH'S HOMETOWN CENTURY 21 OFFICE

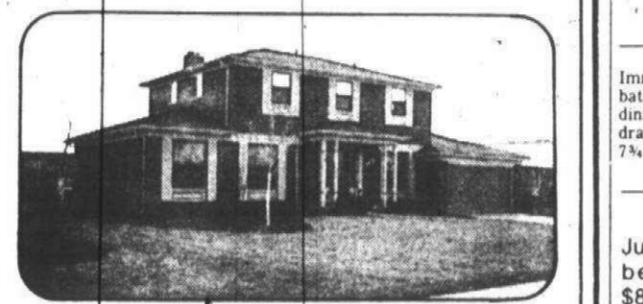

HOME OF THE WEEK
 Northville colony traditional Colonial freshly carpeted and painted this year. Room for the family with 4 bedrooms, 2 1/2 baths, 1st floor laundry, offered to you on a simple assumption or flexible land contract financing. Make a point of taking a look. Call 453-7600.

SIMPLE ASSUMPTION
 Newly decorated 3 bedroom hillside home on 3/4 treed acres. 2 1/2 baths, kitchen totally modernized, fireplace in large family room, enclosed porch and custom wood deck. Call 453-7600.

POTENTIAL INCOME
 Large rooms in this brick 2 story. Make it perfect for a family or a possibility for income investment. 4 bedrooms, fireplace, close to downtown Plymouth. Call 453-7600.

SIMPLE ASSUMPTION
 Spacious 4 bedroom Colonial with family room, featuring brick fireplace and wet bar, 1st floor laundry, 2 1/2 baths, large basement, 2 car attached garage with opener, fenced yard with above ground pool and equipment. All for only \$84,000. Call 453-7600.

OPEN SUNDAY 2-5
 Canton-HAMPTON COURT WEST SUB. 3 bedroom Colonial, 7632 Charrington, \$87,500.

Canton - FRANKLIN PALMER. 3 bedroom ranch, 43761 Antietam, \$62,900.

Canton-NORTH CAVALIER VILLAGE, 3 bedroom ranch, 1228 Franciscan Ct., East, \$81,900.

Century 21 HARTFORD WEST 915 S. MAIN ST., PLYMOUTH 453-7600

WM. FEHLIG
 Real Estate 453-7800
 94 S. Main, Plymouth

PRICED TO SELL AT \$83,900
 Immediate possession. 4 bedroom, 2 1/2 bath colonial, family room, fireplace, dining room, Florida room with cathedral beamed ceiling. L.C. terms or 7 1/4% simple assumption. 455-8359

TRANSFERRED
 Just reduced this lovely 4 bedroom colonial to \$84,500. Super terms. Simple - blend, or land contract. Century 21 Gold House Realtors 459-6000

MAJESTIC VICTORIAN
 Brick pillars lead the way to this eleven room victorian built in 1876. The parlor with hand carved fireplace lends a true feeling of warmth. You'll sense a feeling of nostalgia as the morning rays filter through the stained glass windows, and the built-in leaded glass china cabinet. The kitchen has been remodeled and yet retains its hundred year old charm with the large pantry and first floor laundry. Two stairways ascend to the four large bedrooms or the 3rd floor art studio to the main floor you travel through the den with built-in bookcases and three more fireplaces. The large formal dining room with leaded glass windows was made for entertaining. CR 417 Only \$136,000.

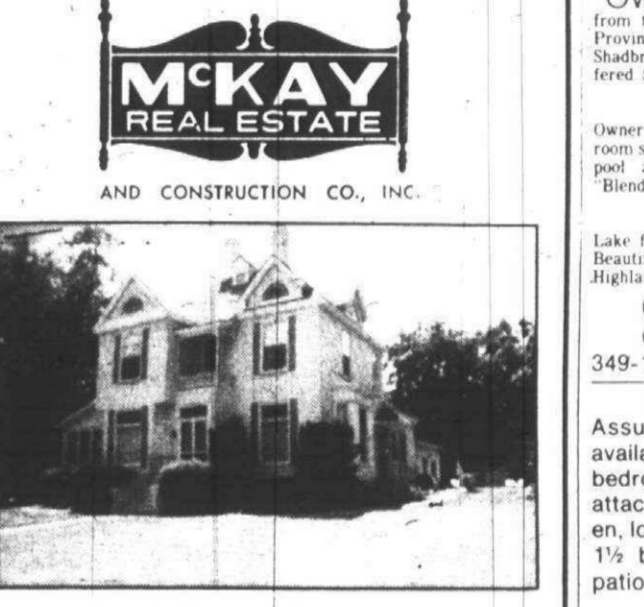

McKay Real Estate
 Brighton (313) 477-8621
 Howell (313) 476-2284

REALTY WORLD W.M. DECKER, INC. PLYMOUTH

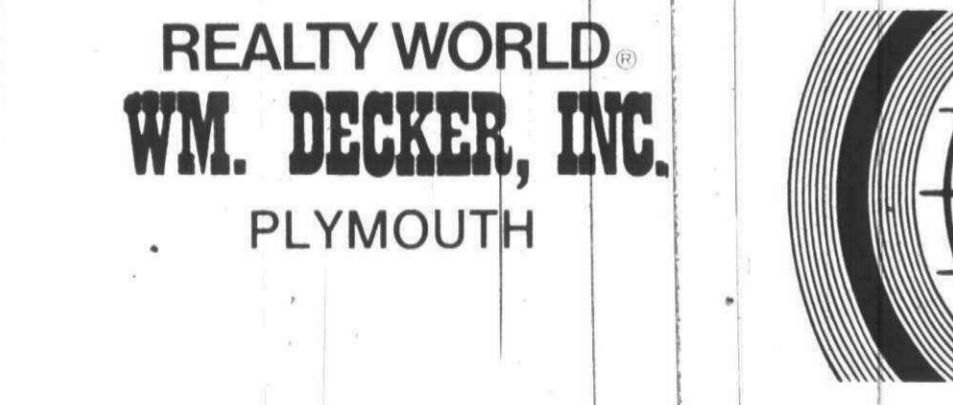

HUNDREDS OF DAFFODILS
 will soon be flowering under the trees in front of this custom, all brick Georgian Colonial nicely offset on 2 1/2 acres west of Plymouth. Quality throughout, it affords four bedrooms, 2 1/2 baths, formal dining room, and family room with Pella windows, six panel doors and magnificent views of the rolling and wooded terrain. \$174,900.

CATCH A FALLING PRICE
 and be the proud owner of a three bedroom Farm Colonial with all the expensive extras, formal dining room, central air, aluminum trim, side entry garage, and the largest lot in the sub! REDUCED \$5,000 below market value. Assume or excellent Blended Rate. \$69,900.

WALK
 to schools and shopping, yet enjoy a wooded setting and a three bedroom brick and cedar ranch. An inviting country kitchen adjoins the cozy family room and the basement is fully finished to extend the living area to the fullest. Land Contract terms offered. \$85,000.

670 S. MAIN STREET 455-8400

LAND CONTRACT TERMS
 Spilling with value at \$64,500. 11% with \$15,000 down. Charming brick 3 bedroom split level. Family room designed for carefree entertaining, has impressive fireplace. Newer furnace, roof and carpeting. Basement, gas heat and many extras. Exceptional value, call today. 525-1810.

ENGLISH-TUDOR COLONIAL
 OLD ROSEDALE. Warm neutral tones make this gracious brick home incomparable. 3 bedrooms, (master bedroom has elegant new fireplace). Living room designed spacious with fireplace. Large formal dining room with carpeting throughout. Gas heat, basement and 2 car garage. Graceful trees adorn this large lot. LAND CONTRACT TERMS or SIMPLE ASSUMPTION. Asking \$84,000. 525-1810.

SAVE MONEY
 Assume the low rate of interest, 8%, \$409.00/month, including taxes. First time offered; be the first to inspect this 3 bedroom brick ranch. Basement, gas heat and 2 car garage. Newer roof and vinyl trim. Private patio with gas grill. Don't miss seeing it TODAY. \$59,900. 525-1810.

DISTINCTIVE
 Traditional 3 bedroom brick ranch with raised foyer to welcome you into this lovely home. Kitchen is designed with busy housewife in mind and opens into cozy family room with fireplace. Basement, gas heat, 2 full baths and 2 car attached garage. SIMPLE ASSUMPTION, and many extras. Asking \$79,900. 525-1810.

Each Office is Independently Owned

REALTY WORLD C. W. ALLEN, INC. LIVONIA



TRADITIONAL
 Winning the approval of all who inspect it. Meticulous 4 bedroom brick and aluminum colonial with 2 1/2 baths. Picturesque setting on cul-de-sac treed lot. Basement, gas heat and large inviting family room with fireplace. The preferred home for the prudent buyer. \$95,900. 525-1810.

COMFORTABLE
 Here's a quiet residential area with schools and shopping just blocks away. Beautifully kept is the right description for this 3 bedroom brick ranch, with 1 1/2 baths. Family room with fireplace, looks onto granite swimming pool off patio. Basement, gas heat and Central Air. Instantly appealing at \$78,900.

SPACIOUS
 split level with distinctive custom quality that reflects your individuality. 3 bedrooms, 2 1/2 baths, and family room with fireplace. Formal dining area. Finished recreation room, gas heat, Central Air and large wood deck with awning. OWNER TRANSFERRED. Professionally landscaped. Asking \$98,900.

TERMS TO SUIT
 ZERO DOWN on V.A. or \$12,000 down on LAND CONTRACT, 11%. Here's a perfect place to welcome Spring. Lovely 3 bedroom brick ranch. Florida room with fireplace and 2 car attached garage. In an area of nice homes. Realistic price \$48,900.

15337 FARMINGTON RD. 525-1810

Martin, Ketchum & Martin REALTORS 522-0200
 31172 FIVE MILE ROAD at Meridian, Livonia

EARL KEIM REALTY REALTORS
 "The Helpful People!"
 A network of franchised offices.

ASSUME LOW INTEREST RATE. Newer 3 bedroom ranch in Plymouth Township, full basement, garage. 1 1/2 baths. \$65,900.

A LOT OF HOME FOR NOT A LOT OF MONEY 4 bedroom Colonial with 1 1/2 baths, family room with fireplace, enclosed patio. \$68,900.

SIMPLE ASSUMPTION. 3 bedroom all brick home with family room, fireplace, 2 baths, finished lower level. \$69,900.

\$1500 MORTGAGE SUBSIDY. Spacious ranch with formal dining room, landscaped lot, 3 bedrooms, family room, fireplace central air. \$71,900.

PRIVATE COURT LOCATION. 3 bedroom, 2 full baths, open family living area and a private formal dining room. \$73,700.

ASSUME AT 13%. Beautiful ranch with upgraded carpeting, solarium floor in kitchen and foyer. 3 bedrooms. \$82,000.

TWO ACRES IN PLYMOUTH TOWNSHIP. Older farm house with lots of trees, separate 2 car garage, 5 bedrooms. \$87,500.

A HOME IN THE COUNTRY. One acre, 2 baths, 3 large bedrooms, stone fireplace and more. Brick ranch for \$89,900.

LAND CONTRACT TERMS on this sprawling 5 acre ranch in New Boston, corralled area with barn, walkout basement, sun room, fireplace, 2 baths. \$119,000.

BELOW MARKET INTEREST RATES. 3 bedroom all brick, park location, pass hall, and 2 full baths. \$72,500.

EARL KEIM REALTY SOUTH, INC. 453-0012

316 Westland Garden City

DRASTICALLY REDUCED Excellent 3 bedroom ranch...

FEEL CRAMPED? Spread out in this 1600 sq. ft. ranch...

FIX & SAVE Great starter with basement, gas heat, new bathroom...

GARDEN CITY BEST AREA!! Three bedroom brick ranch...

Good Assumption Three bedroom brick ranch with finished basement...

GREAT TERMS on this immaculate 3 bedroom brick ranch...

IMMACULATE Tastefully decorated 3 bedroom brick ranch...

LARGE FAMILY? Brick colonial in prime area...

Owner Transferred Priced to sell - maintenance free ranch...

1ST HOME BUYER Call today on this beautiful brick ranch...

LAND CONTRACT 10% is offered with \$400 monthly payments...

ONLY \$5000 MOVES in 4 bedrooms, basement, 2 car garage...

ONLY 13 1/2% interest - \$5000 down Swim pool, lovely 3 bedroom brick...

Well located four bedroom Colonial in Canton's "Carrage Hills Sub"...

For Lease: Northville Commons Colonial - 4 bedrooms - Immediate Occupancy...

316 Westland Garden City

LIVONIA SCHOOLS BRICK RANCH, 3 bedrooms, plush carpeting...

NEW WORLD SUMMIT 427-3200

LIVONIA SCHOOLS In a prime area of north Westland...

LOWER INTEREST RATES Available with as little as \$2200 down...

NEAR PERFECT Very spacious 3 bedroom brick ranch...

NEWLYWEDS \$39,900 and sparkling clean brick ranch...

OPEN SUN. 1-5 JUST REDUCED! Owners must sacrifice...

VETERANS ONLY Garden City, Ford - Venoy area...

316 Westland Garden City

OPEN SUN. 2-5 39246 DILLINGHAM (S. of Cherry Hill...

WOW \$9900 Down assumes custom built 3 bedroom brick ranch...

TERMS Assumption, land contract or blended rate available...

TERMS Terms Terms Assumption or low down land contract on this special 3 bedroom colonial...

UNDER PRICED Priced below the market for quick sale is this immaculate 3 bedroom brick ranch...

WESTLAND, by owner, mid 3 bedroom ranch, many extras...

Blended rate available on new mortgage for this lovely 4 bedroom tri-level in a good location...

Over 1/2 acre lot, all aluminum starter home 2 spacious bedrooms, remodeled kitchen, newer roof, hardwood floors...

Over 1/2 acre lot, all aluminum starter home 2 spacious bedrooms, remodeled kitchen, newer roof, hardwood floors...

316 Westland Garden City

WESTLAND, 3 bedroom brick home, new furnace, 1 1/2 car garage...

CASTELLI 525-7900

ASSUMABLE MORTGAGE on newly decorated 2 bedroom bungalow, large kitchen, basement, fenced yard...

BARGAIN 3 bedroom brick bungalow with full basement and garage...

BOTH OPEN SUN. 1-5 Franklin fireplace - 1944 Imperial Highway, No. of Grand River...

Large lot - 15453 Winston, No. of 5 Mile, W. of Telegraph...

BRICK 2 bedroom, full dining room, carpeting, drapes, finished basement...

Brimming Brick Ranch Excellent neighborhood for this just listed brick home with 3 bedrooms...

BY OWNER, 2 bedroom, crawl, aluminum, 2 car garage, treed corner lot...

COUNTRY LOT Large treed lot with loads of garden space...

CUSTOM-CUSTOM Brick split-level with almost 3000 sq. ft. of luxurious living space...

REDFORD SOUTH 3 bedroom brick ranch, 1 1/2 baths, 1 1/2 car garage...

REDFORD TWP. By Owner, 2 bedroom, brick aluminum trim, 1 1/2 bath, full basement...

REDFORD TWP. 3 bedroom ranch, 1 1/2 baths, full basement, 2 1/2 car garage, fenced yard...

318 Redford

Family Room/Fireplace South Redford - 3 bedroom brick ranch, features finished basement with wet-bar...

CENTURY 21 NADA 477-9800

LAND CONTRACT Good terms available on this 3 bedroom home, nicely decorated throughout...

OPEN SUN. 1-4 25260 DONALD Executive ranch, 3 bedroom brick, full finished basement...

CAMBRIDGE 459-4620 REDFORD Assumption or new mortgage at below market interest rates...

Rymal Symes REDFORD, JERRY STILL "Land Contract" 7 YEARS!

ROOM GALORE 4 BEDROOMS Just purr-fect for the large family...

Red Carpet RICHTER & ASSOC 522-3500

HITCHCOCK Gallery of Homes 607 S. MAIN ST. PLYMOUTH

453-2210

GARDEN CITY Maintenance free aluminum ranch featuring 3 bedrooms...

FRESHLY DECORATED Brick ranch featuring 3 bedrooms, full basement with 2 1/2 car garage...

DEARBORN Sharp maintenance free bungalow in fine area featuring 3 bedrooms...

WESTLAND FANTASTIC LAND CONTRACT TERMS available on this sharp maintenance free 4 bedroom home...

WESTLAND Immaculate well decorated brick ranch featuring 3 bedrooms...

WESTLAND Sharp brick ranch featuring 3 bedrooms, large living room...

WESTLAND Sharp Bi-Level featuring 2 possible 3 bedrooms, dining area...

COLONIAL 4 bedroom, dining room, family room with fireplace, large attached garage...

318 Redford

REDFORD OPEN SUN. 2-5 25711 LYNDON Gracious living and privacy in this attractive custom built ranch...

PRICE REDUCED MINT CONDITION 3 bedroom Brick Ranch, Newly decorated...

EARL KEIM 538-8300 REDFORD INC.

REDFORD "4 & BEECH" Ranch home, family room, full wall fireplace...

"ZERO DOWN" Spacious 3 bedroom ranch with country kitchen and garage...

Sharp 3 bedroom brick with formal dining room, full basement and garage...

CENTURY 21 TODAY 538-2000

319 Homes For Sale Wayne County LET'S TALK

4 bedroom brick ranch with professionally finished basement...

CHAMBERLAIN 388-2200

319 Homes For Sale Wayne County

LAND CONTRACT TERMS S. of Gunwood, E. of Newburgh...

MAYFAIR 522-8000

N.W. DETROIT NICE AREA!! Schoolcraft & Outer Drive...

Real Estate NETWORK Harrison Moore 427-9030

ROSEDALE GRANDMONT SUB As Low as 10% Down Brick colonial 2 bedrooms...

BIRMINGHAM Open Sat & Sun 1 to 5 1420 Yosemite 3 bedroom quality built brick ranch...

302 Birmingham Bloomfield

ARCHITECT'S DESIGN - LAND CONTRACT - BLOOMFIELD'S BEAUTIFUL KIRK-IN-HILLS AREA...

ASSUMPTION SIMPLE Beverly Hills, 3 bedroom 1 1/2 bath ranch, family room, fireplace...

ATTRACTIVE BIRMINGHAM ranch 3 bedrooms, 2 baths Florida room Full basement, 2 car garage...

TAYLOR - Metro Airport area, farm house with efficiency apartment...

BIRMINGHAM Open Sat & Sun 1 to 5 1420 Yosemite 3 bedroom quality built brick ranch...

302 Birmingham Bloomfield

M1237-Rochester, 4 bedrooms 2 1/2 baths Transferred Owner K1427-Lakefront, 3 bedrooms Land Contract \$104,900

N1230-Rochester, 4 bedrooms 2 1/2 baths L.C. or Assume, \$93,000 E970-Clawson, 3 bedrooms, 1 1/2 baths, L.C. of assume, \$66,900

G1010 - Clarkson, 3 bedrooms 1 1/2 baths, extras \$54,500

884 S. ADAMS BIRMINGHAM 642-1620 1-800-462-6150

SHARE ADVERTISING INC.

302 Birmingham Bloomfield

ALL BLOOMFIELD HILLS SCHOOLS SHERBY HOMES is proud to offer custom quality homes...

BIRMINGHAM IN TOWN - Luxury home, all brick, Contemporary 3 bedrooms, 2 full baths...

BIRMINGHAM Located in one of the most desirable areas, center entrance...

ASSUMPTION SIMPLE Beverly Hills, 3 bedroom 1 1/2 bath ranch, family room...

ATTRACTIVE BIRMINGHAM ranch 3 bedrooms, 2 baths Florida room Full basement, 2 car garage...

TAYLOR - Metro Airport area, farm house with efficiency apartment...

BIRMINGHAM Open Sat & Sun 1 to 5 1420 Yosemite 3 bedroom quality built brick ranch...

302 Birmingham Bloomfield

M1237-Rochester, 4 bedrooms 2 1/2 baths Transferred Owner K1427-Lakefront, 3 bedrooms Land Contract \$104,900

N1230-Rochester, 4 bedrooms 2 1/2 baths L.C. or Assume, \$93,000 E970-Clawson, 3 bedrooms, 1 1/2 baths, L.C. of assume, \$66,900

G1010 - Clarkson, 3 bedrooms 1 1/2 baths, extras \$54,500

884 S. ADAMS BIRMINGHAM 642-1620 1-800-462-6150

SHARE ADVERTISING INC.

EARL KEIM REALTY ...The Helpful People! REALTORS® A network of franchised offices

VACANT LAND Plymouth-Exceptional building site in subdivision of custom homes \$335,900

DEARBORN Sharp maintenance free bungalow in fine area featuring 3 bedrooms...

WESTLAND FANTASTIC LAND CONTRACT TERMS available on this sharp maintenance free 4 bedroom home...

WESTLAND Immaculate well decorated brick ranch featuring 3 bedrooms...

WESTLAND Sharp brick ranch featuring 3 bedrooms, large living room...

WESTLAND Sharp Bi-Level featuring 2 possible 3 bedrooms, dining area...

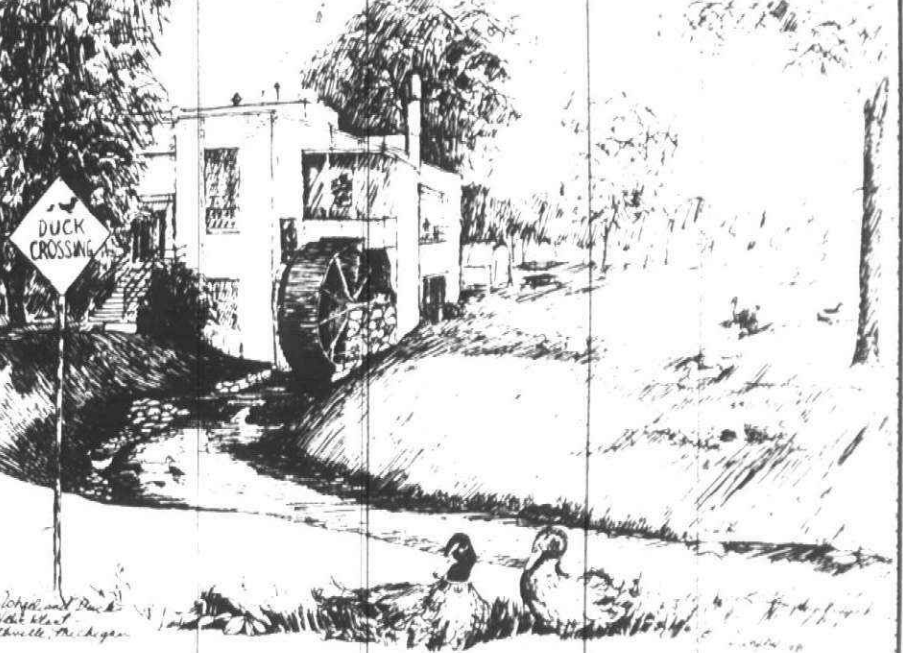
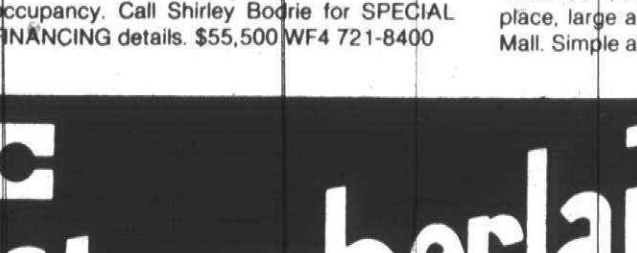
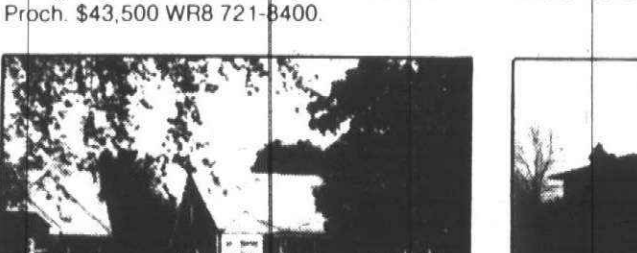
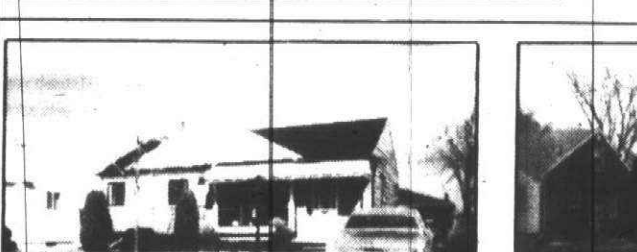

Northville's old world charm surrounds you at ... Beacon Woods North

Discover Northville's Old World Charm in it's newly restored downtown, beautiful parklands, churches and it's traditional atmosphere...

12 3/4% 30 YEAR MORTGAGES Priced from Mid 1120's Model Hours Daily & Sunday 1-7 Closed Thursday

Table with 2 columns: BECK, NINE MILE, BEACON WOODS NORTH, SHILBORN, HAGGERTY, EIGHT MILE

GARDEN CITY Maintenance free aluminum ranch featuring 3 bedrooms, kitchen appliances and window treatments...

FRESHLY DECORATED Brick ranch featuring 3 bedrooms, full basement with 2 1/2 car garage...

DEARBORN Sharp maintenance free bungalow in fine area featuring 3 bedrooms, formal dining room...

WESTLAND FANTASTIC LAND CONTRACT TERMS available on this sharp maintenance free 4 bedroom home...

WESTLAND Immaculate well decorated brick ranch featuring 3 bedrooms, family kitchen...

WESTLAND Sharp brick ranch featuring 3 bedrooms, large living room, 1 1/2 baths, fully tiled basement...

WESTLAND Sharp Bi-Level featuring 2 possible 3 bedrooms, dining area, 1 1/2 baths, family room...

COLONIAL 4 bedroom, dining room, family room with fireplace, large attached garage...

302 Birmingham Bloomfield
AT 11% FINANCING. This Wake Forest home is a bargain! The ultimate in luxurious living with 4600 sq. ft. plus walkout basement. 57 ft. first floor master suite with fireplace, jacuzzi & steam bath. 3 full, 2 half baths. 3 car garage, lots of glass, high ceilings & balconies, premium lot. Seeing is believing. Call for your personal inspection. Sherry Homes, 557-0770. 642-7911

302 Birmingham Bloomfield
BEVERLY HILLS - Georgetown. By owner. Beautifully maintained 4 bedroom, 2 1/2 bath, air conditioned colonial. \$139,500. 646-1116
BEVERLY HILLS - Brook Ranch on quiet dead end street. Birmingham Schools. Walk to parochial school. 3 bedrooms, dining room, living room with fireplace, kitchen with eating space, family room and side fireplace in living room. Super rec room with bar & bedroom in large FINISHED BASEMENT. Central air. \$89,500. 647-2488

302 Birmingham Bloomfield
BEVERLY HILLS (13 MILE LAKE AREA) BIRMINGHAM ADDRESS & BIRMINGHAM SCHOOLS. WELL MAINTAINED 3 bedroom 2 bath brick ranch with attached 2 car garage. In over HALF ACRE in beautiful, secluded wooded area. Brick raised hearth fireplace in family room and side fireplace in living room. Super rec room with bar & bedroom in large FINISHED BASEMENT. Central air. \$89,500. 647-2488

302 Birmingham Bloomfield
BIRMINGHAM BY OWNER
3 bedroom, fenced yard, deck, full basement. Must sell. No L.C. 937 Smith. \$43,000 455-2500 or 646-4396
BIRMINGHAM cape cod, western view of Birmingham country club. 3 bedrooms, 2 full baths, 2 fireplaces, & much more. Assumable 9% mortgage, asking \$135,000. 1899 Norfolk 646-4252

302 Birmingham Bloomfield
BIRMINGHAM
MIDVALE AREA. Immaculate colonial with fireplace living room, screened porch, beautifully finished rec room. 3 bedrooms, 1 1/2 baths \$116,000
ON THE LAKE. Pillared colonial backs to Lake Kirkwood for year-round enjoyment. Finished library, fireplace family room, patio, 4 bedrooms, 4 walk-in closets, 1 1/2 baths. Central air. \$149,900

302 Birmingham Bloomfield
CLASSIC BIRMINGHAM COLONIAL
By Owner - 4 bedroom, 1 1/2 baths, close to Phippleton Park and in town. Birmingham. Exceptional 1920's quality, charm and brick construction. Immaculate interior includes refinished oak floors and birch trim thru-out. \$128,500 at 9% assumption. S-1198. Open Sat. 2 to 5 PM 815 Oakland 645-3438 SHARE LISTINGS 642-1620

302 Birmingham Bloomfield
BLOOMFIELD HILLS
Really creative financing will put you in this sharp 4 bedroom 2 1/2 bath colonial with many extras. Decorated in popular neutrals, 2 way natural fireplace, large family room overlooks acres of woods. Large 1st floor laundry, all large customized closets. \$123,500 - Call Dorothy Craven

302 Birmingham Bloomfield
LUXURY LIVING
Custom built Wright contemporary in Bloomfield Hills on approx. 2 acres has every imaginable extra. 19 rooms, 5 bedrooms, 2 family rooms, 5 furnaces. Over 11,000 sq. ft. of quality living includes maid's quarters, Turkish bath, gym & hillside rooms, formal dining room seats 24 & beautiful Mediterranean kitchen. Must be seen. \$795,000

302 Birmingham Bloomfield
CONVENIENCE. 20 minutes to downtown Detroit. Immaculate 4 bedroom colonial. 2 1/2 baths, separate dining room, large family room with fireplace, large kitchen, circle drive, walking distance to St. Hugo's and East Hills. High \$98,000.

302 Birmingham Bloomfield
BIRMINGHAM - Cape Cod 3 bedroom, formal dining area, updated kitchen, 2 car garage, move in condition, very well landscaped large lot. Very attractive mortgage \$82,900 Open Sun. 12:00-4:00 646-0538

Redding 569-7020
BINGHAM FARMS
Highly desirable 3 bedroom, 3 bath ranch offering complete PRIVACY and SECLUSION on over 5 ACRES of magnificent wooded grounds. Property includes a 2 bedroom Guest House. 4 horses allowed. \$399,000. Call today for appointment.

302 Birmingham Bloomfield
BIRMINGHAM \$59,900
1601 COLE - OPEN SUN 2-5
3 bedroom aluminum bungalow, FAMILY KITCHEN 50' corner lot, 2 1/2 car garage, gas heat, rec room. SILENT ASSUMPTION \$40,300 MORTGAGE or SHORT TERM LAND CONTRACT. BIRMINGHAM REAL ESTATE. 642-4500

302 Birmingham Bloomfield
Ralph Manuel Associates
1821 W. Maple 647-7100 Birmingham
BIRMINGHAM - Pembrook Manor Open Sunday, 1 to 4 1/4 story brick newly decorated 3 bedrooms, updated kitchen and bath, fireplace, fully carpeted, 1 1/2 car garage. Simple assumption. \$72,500. 649-5971

Century 21
FAIR TOWNE CO.
626-8000
BLOOMFIELD RANCH
OPEN SUN 1 to 5, 480 S. Evansdale near Charing Cross, N of Wiggins, W of Adams 3 bedrooms, 2 baths, full basement, beautifully landscaped acre walk to commuter many amenities. Greater Bimfd Rhodes 642-0014

302 Birmingham Bloomfield
BY OWNER Bloomfield Twp near Square Lake & Telegraph 1,600 sq. ft. 4 bedrooms, full basement, 1/2 acre. 11% Land Contract or Assump. \$66,900 336-8213

302 Birmingham Bloomfield
MAJOR REDUCTION
GREAT TERMS! Custom Robertson built Quad-level in prestigious Whisper wood on great half acre corner lot. 4 bedrooms, 3 full baths, spacious fire placed family room. Florida room, rec room. Immaculate, lovely decor. Many extras. Priced to sell \$153,500. ASK FOR FRANK KUHIN

303 West Bloomfield
BUILDER'S MODEL CLOSET/IT
4 bedroom colonial 2 1/2 baths large kitchen with breakfast nook & appli areas. 1st floor laundry, formal dining, family room with wet bar & fireplace. 2 car garage, complete landscape. 9 1/2 financing. LaDorville Homes 474-2930

THINK SPRING
Country living. Nearly half acre surrounds this immaculate, 3 bedroom brick ranch. Built-ins modern kitchen, dining room, fireplace, 2 1/2 car garage. \$68,900
5 Years Old+
Very attractive tri-level, 3 bedrooms, 1 1/2 baths, family room with fireplace, large kitchen, 2 car garage with opener. \$67,900.

ROYAL
Presents this Amazing New Home Special for March 1981
\$55,840 - COMPLETE!
Offer good thru March 31, 1981. Freeze prices for spring start! Features quality home construction at lowest possible price including energy saving packages! Has hundreds of plans to choose from - or bring your own. Has owner participation programs saving you thousands! Or we do it all. Still has 11% financing available for qualified customers.

11 1/2% FINANCING
Charming Dutch Colonial on beautifully treed lot in Quanton area. Totally renovated inside & out. Huge modern kitchen, 3 bedrooms, 2 full baths, or 2 bedrooms & den. Must see to appreciate. \$138,800.
Ask for Helen Rose RE/MAX of Birmingham, Inc 647-0500

CRANBROOK RD.
- 1 ACRE - PRESTIGIOUS BLOOMFIELD VILLAGE - 6 BEDROOMS -
Beautifully landscaped, elegant 2 story home. Newly decorated. All large rooms.
-Living Room - 35x20
-Family Room - 35x20
-Formal Dining Room - 13x12
-3 Fireplaces - Marble Foyer

302 Birmingham Bloomfield
GREAT VALUES
ASSUMABLE at 8 1/2% - ideal starter home. 2 bedrooms, 1 1/2 baths. Birmingham ranch near schools, train & shopping. Only \$37,500 645-5800
IMMEDIATE - possession, L.C. & much more offered on this extra special Birmingham bungalow. 3 bedrooms, 2 car garage, priced to sell \$59,900. 645-5800

302 Birmingham Bloomfield
Earl Keim Realty GREENTREES
689-3600 645-5800 649-5100
JUST LISTED!
Sharp on large lot in Bloomfield Hills. 3 bed, 3 bath, 3 bedrooms, 1 bath plus 2 half. Many Extras! Assumable Mortgage asking \$106,000

RED WING TICKET WINNER
Mrs. Daniel Barnes 25500 Keeler Redford
Please call the promotion department of the Observer & Eccentric by 5 p.m. Friday, March 13, 1981 to claim your 2 free RED WING TICKETS. 591-2300 ext 244

CLARK/FRON REALTY
27482 FIVE MILE LIVONIA
425-7300
CAREER IN REAL ESTATE
Unique opportunity for the right person with a long established, reputable broker.

ROYAL PRIDE
801 W. Telegraph Carleton 586-8411
ROYAL CROWN
4370 Michigan Canton 397-1220

CONTEMPORARY QUAD
Builder's own 3650 sq. ft., 3 bedroom, 3 1/2 bath half built, custom built home. Family room and guest suite, formal dining room, custom kitchen, circular drive, central air, alarm system, and for total enjoyment, an inground 20x38 heated pool. Land Contract 10% or 13 1/2% mortgage available \$249,000. For appointment, call weekdays 352-2013, weekends 569-1050

IMMEDIATE - possession, L.C. & much more offered on this extra special Birmingham bungalow. 3 bedrooms, 2 car garage, priced to sell \$59,900. 645-5800

Levelly 4 bedrooms, 2 1/2 baths, center entrance Colonial in family neighborhood in Bloomfield Hills. Family room with fireplace, beamed family room. Assumable Mortgage Asking \$117,500

CENTURY 21
MUL CORPORATE TRANSFER SERVICE
851-6700

DEERFIELD VILLAGE, 4 bedroom Colonial in excellent location. 450-0600

UNIQUE COMBINATION
of custom building, decorating and professional landscaping located in sought after Walnut Creek in Plymouth, 4 bedroom ranch with all the amenities for all seasons - livability plus 9% assumable mortgage. \$185,000. 453-6800

12 1/2% FINANCING
Now Colonial offers many beautiful features. Such as hand stained wood trim, unique wood flooring, etc. 3 bedrooms, 2 1/2 baths, spacious kitchen, family room, heated 2 car garage. Only \$71,900. 522-5333

Super Custom Home By Owner
Plymouth/Canton Area \$89,900
4 Bedroom Colonial
2 1/2 Baths
Family Room with fireplace, wet bar
Attached 2 1/2 car garage with side entrance, oversize drive
Brick with aluminum trim
1st floor laundry
2250 sq. ft. of living area
Plymouth schools

Call Gwen Hanauer 647-1117 after 7PM 684-6300
WEIR, MANUEL, SNYDER & HANKE
KIRK OF THE HILLS AREA
BY OWNER \$159,900
Below Market Mortgage Rate! Brick Ranch on beautifully treed 1 1/2 acres. Spacious living room with walkout to deck on upper level. Completely finished lower level has large family room with walkout to patio, 3 to 5 bedrooms, 2 full baths, 2700 sq. ft. Wet plaster, hardwood floors, recently refinished. New features include roof, wiring, plumbing, carpeting, & much more. Best see to appreciate. Priced well below Appraised Value for Quick Sale. Immediate occupancy. Will also consider Land Contract. Full weekdays, 855-1078, or after 6:30 & weekends, 855-1639 or 1-667-9335. OPEN HOUSE, SAT & SUN 2-6 PM at 1319 Graton Road

GOODE REAL ESTATE
A Good Listing Is Always Hot! 1411 N Woodward 647-1898
ST. HUGO-OF-THE-HILLS IMMEDIATE OCCUPANCY
BIMFD HILLS COLONIAL
Deluxe Colonial on a large fenced lot. 4 bedrooms, 2 1/2 baths, family room with fireplace, built-in breakfast area in kitchen. First floor laundry. Finished recreation room. Very attractive financing available. \$109,000

OPEN SUN. 1-4
Land Contract 5 years
Master bedroom highlights this spacious 4 bedroom colonial. Lovely brick kitchen, family room with full wall fireplace, 2 1/2 baths, added recreation room, carpeting. \$117,500. Vacant. \$226. Outburst N of Maple W of Farmington

LUXURY ABOUNDS
in this 4 bedroom quad in Canton, beautifully finished recreation room plus a family room, dining area, energy package, sprinkling system are only some of the extra features, a must to see. \$99,900 453-6800

FANTASTIC ASSUMPTION
Less than \$10,000 assumes this 12 1/2% mortgage. Beautiful 3 bedroom brick ranch in prime Livonia location. Family room, finished basement. 2 car garage. \$64,900. 522-5333

Simple Assumption 7 1/4% or Special 13 3/4% rate.
43146 Fernwood, North of Ford Road, West of Lilley. 455-8769 Shown by Appointment

INTOWN Birmingham faces community house, 3 bedroom, 1 bath colonial living room with fireplace & bookshelves, dining room, complete kitchen, new ceramic bath, stained wood kitchen, custom lighting fixtures, new carpeting & basement \$87,900. 648-5914

ASK FOR ALICE RUTTEN
RE: AK of Birmingham Inc. 647-0500 or 644-2983
UNDENIABLE CHARM
INSTANT CBIER APPEAL, equals appealing inside. Newly listed 3 bedroom 2 1/2 bath ranch with fireplace family room, big deck in beautiful yard, updated kitchen, 6 panel doors. In prime Bloomfield Hills area near conveniences \$108,400. ASK FOR PERN WAGGONER

Max Broock, Inc. 626-4000
For the quality conscious buyer, FAIRFIELD DEVELOPMENT CO. presents a home with old-fashioned workmanship and contemporary energy features. Special luxuries include interior atrium, 3 fireplaces, master bedroom with his & her baths, plus whirlpool tub, Mutschler kitchen cabinetry, wrap around deck, complete landscaping and much more. Bloomfield Hills Schools \$325,000

MAINTENANCE FREE
brick ranch in Westland adjacent to scenic Edward Hines Park, simple assumption or land contract available, owner anxious. \$52,900. 453-6800

INVITING
Assumable Mortgage or on this unique home that offers 3 large bedrooms, 2 full baths, formal dining, family room with fireplace, attached 2 car garage. Finished recreation room, expansive rear yard. \$98,900. 522-5333

SEASONAL VIEWS
Of the Clinton River and surrounding woods will be yours to enjoy in this unusual two bedroom condominium. One full and two half baths. Fireplaced living room opens to balcony. Walk-out recreation room leads to patio. \$78,000. 644-3500

CRANBROOK
Assoc. Inc. Realtors 645-2500
11% Land Contract
Brand new 4 bedroom 2 1/2 bath colonial
Middle open days except Thurs. 1pm-6pm
2816 Woodcreek Way
1/2 acre add bet. Long Lake & Square Lake Rd.
W of Eastways Rd. off Great Oaks Dr.
Roger Lockwood & Co. 647-0760-644-4024

Chamberlain 646-6000 858-8706
OPEN SUN. 2-5
Charming Beverly Hills brick ranch. Three bedrooms, one full, two half baths, dining room, fireplace, living room. Lovely glassed in porch 3119 Maxwell. N. of 51st Mile between Southfield & Evergreen. \$94,500

OPEN SUN. 1-4
642-1142
Located at Hambleton on Middlebelt S. of Long Pine
We build to suit.
Buyer participation invited.

JUST LISTED
Assume or 20% down and interest rate will be 12 1/2% on this lovely 3 bedroom in Plymouth Township. Upgraded features, family room with fireplace, newer carpet and many extras make this a great buy at \$68,900. 453-6800

LAND CONTRACT
terms on this 3 bedroom brick ranch in Livonia. TWO natural fireplaces, formal dining room, completed recreation room, garage. Summer fun ahead in the heated Gunite POOL. Covered patio. Only \$68,900. 522-5333

SPECIAL FINANCING AVAILABLE!
Newly constructed Colonial residence in convenient Farmington Green. Three bedrooms. Bonus Room, fourth bedroom or library. Two full and one half baths. Fireplaced family room. Farmington Hills. \$121,900. 644-3500

OPEN SUN. 2-5
Charming Beverly Hills brick ranch. Three bedrooms, one full, two half baths, dining room, fireplace, living room. Lovely glassed in porch 3119 Maxwell. N. of 51st Mile between Southfield & Evergreen. \$94,500

CRANBROOK
Assoc. Inc. Realtors 645-2500
11% Land Contract
Brand new 4 bedroom 2 1/2 bath colonial
Middle open days except Thurs. 1pm-6pm
2816 Woodcreek Way
1/2 acre add bet. Long Lake & Square Lake Rd.
W of Eastways Rd. off Great Oaks Dr.
Roger Lockwood & Co. 647-0760-644-4024

OPEN SUN. 1-4
642-1142
Located at Hambleton on Middlebelt S. of Long Pine
We build to suit.
Buyer participation invited.

NEW ON THE MARKET
Three bedroom ranch in Canton is former model with many extras, bay window in living room, super large family room, master bath, access and full basement are only some of the highlights. \$72,900. 453-6800

FIRST OFFERING
Spacious custom built tri-level in much sought after "Burton Hollow." Four bedrooms, huge family room plus recreation room, 2 1/2 baths, formal dining room. Decorated to perfection. \$89,500. 522-5333

CHARM... CONVENIENCE
Lovely English Tudor residence... close to shopping and transportation. Two bedrooms. Fireplaced living room. Paneled family room. Hobby room. Updated kitchen. Paneled recreation room with fireplace. Assumable Mortgage. \$53,000. 644-3500

CRANBROOK
Assoc. Inc. Realtors 645-2500
11% Land Contract
Brand new 4 bedroom 2 1/2 bath colonial
Middle open days except Thurs. 1pm-6pm
2816 Woodcreek Way
1/2 acre add bet. Long Lake & Square Lake Rd.
W of Eastways Rd. off Great Oaks Dr.
Roger Lockwood & Co. 647-0760-644-4024

Chamberlain 646-6000 858-8706
OPEN SUN. 2-5
Charming Beverly Hills brick ranch. Three bedrooms, one full, two half baths, dining room, fireplace, living room. Lovely glassed in porch 3119 Maxwell. N. of 51st Mile between Southfield & Evergreen. \$94,500

OPEN SUN. 1-4
642-1142
Located at Hambleton on Middlebelt S. of Long Pine
We build to suit.
Buyer participation invited.

GUARANTEE SALES PLAN
Schweitzer Real Estate, Inc.
Better Homes and Gardens
PLYMOUTH/CANTON OFFICE
218 S. Main St. - North of Ann Arbor Trail 453-6800
LIVONIA OFFICE
32714 W. Five Mile - East of Farmington Rd 522-5333
Office Open Weekdays 8:30 a.m. to 7 p.m.
Saturdays 8:30 a.m. to 5 p.m. Sundays 10 a.m. to 4 p.m.
626-5900 644-3500

THE GREENHOUSE
Come see the exciting and spacious new concept in PASSIVE SOLAR living. Our HOME INCLUDES such luxury features as a 2 STORY FOYER with ceramic tile floor, a 2 STORY LIVING ROOM with a 16' high heat circulating FIREPLACE, A DINING ROOM served by a pass-through from the LUXURY equipped KITCHEN that includes plenty of cabinets plus a pantry, planning desk, broom closet, dishwasher disposal, vent fan and large nook. Also on the 1st floor is a DEN, UTILITY ROOM AND FULL BATH. THE LIVING ROOM, DINING ROOM AND DEN HAVE DOORWALLS LEADING TO A 2 STORY SOLARIUM.
THE SECOND FLOOR HAS 3 BEDROOMS, THE MASTER BEDROOM has twin closets and a LUXURY BATH FEATURING A ROUND ROMAN TUB with mirrored walls, a stall shower and room for a sauna. TWO OF THE BEDROOMS HAVE DOORWALLS LEADING TO BALCONIES THAT OVERLOOK THE SOLARIUM. (Great for sitting)
The house is a Passive Solar Envelope design that can be 100% Energy Efficient.
IF YOU ARE INTERESTED IN A LUXURY, ENERGY EFFICIENT HOME, YOU WILL ENJOY THIS HOME.

303 West Bloomfield

OPEN SUN. 2-5
LAKE PRIVILEGES
Country atmosphere, acre of trees,
pond and wildlife accentuate this
exciting triple level. Walk out family
room, 2 1/2 baths, full kitchen, carpeting,
newer roof & garage doors, green
house. Nature lover! Don't miss this
one! \$146,500. 4591 Arrowhead, W. of
Orchard Lake Rd. S. of Pontiac Trail.
Call 363-8307.

CENTURY 21

SCENTINE ASSOC.
626-8800

LAKE LIVING
OPEN SAT. - SUN. 12-3
Magnificent new 4 bedroom home
among towering pines with privileges
on Upper Straits Lake. Designed for
gracious living & entertaining. Custom
features thru include deluxe custom
kitchen, Kohler fixtures & much more.
Priced at \$197,500. 4546 Rolling Pines
Ct., Pontiac Trail, W. of Halsted.
PINE LAKE HOMES 851-9117

CENTURY 21

ROBEC PROPERTIES
851-7711
EXECUTIVE RELOCATION
SERVICES

UNIQUE
Lakewood of W. Bloomfield
is the location of this quality
CONTEMPORARY nestled in a tree
setting, this home features 4 bedrooms,
2 1/2 baths & a dramatic fireplace in the
family room. Property backs up to
vacant land. \$159,900.

Max Broock, Inc.
626-4000

WEST BLOOMFIELD
LAND CONTRACT
IMMEDIATE OCCUPANCY
Move right into this 3 bedroom brick
ranch, with Sylvan Lake privileges.
Call today! \$54,900

CENTURY 21

FAIR TOWNE CO.
626-8000

Land Contract
Flexible terms on one open 4 bed
room, 2 1/2 bath colonial with both family
room & den plus central air & sprinklers.
Wooded rear yard. \$127,500. Con-
tract.
Norma Zelich 851-3152, 851-6004

THE DURBIN

COMPANY REALTORS
Your Neighborhood Broker

LARGE TREES FRAME brick ranch in
neighborhood of custom homes. Large
California driftstone fireplace opens to
living room. \$97,900

Chamberlain

W. Bloomfield
851-8100

**Middle Straits
Lake Privileges**
SIMPLE ASSUMPTION
Traditional brick & aluminum 3 bed
room tri-level, 1 1/2 baths, 2 car
garage, fireplace family room, West
Bloomfield schools. Only 9 years old.
Huge yard, country setting. MAKE OFF-
ER! Asking \$64,500. Call 363-8307.

CENTURY 21

OLD ORCHARD

OPEN SUNDAY 2-5
1100 4076 OLD DOMINION, N. of
Walnut Lake W. of Orchard Lake.
Large 4 bedroom colonial in
neighborhood of attractively decorated
colonial homes. Best value in West
Bloomfield. Rooms all generous in size.
Excellent financing options available.
\$119,900

CENTURY 21

EXECUTIVE TRANSFER SALES
851-4100

OPEN SUNDAY!
30 Year Land Contract terms. Modern
4 1/2 bedroom Brick Quad. Spacious
kitchen, with all the appliances.
Furnished library with bookcase, 2 1/2
family room with fireplace, central air,
excellent locations. Asking \$115,900.

CENTURY 21

MJL CORPORATE
TRANSFEREE SERVICE
851-6700

OPEN SUN. 2-5
ORCHARD CREST NORTH
6088 Kiev
Just reduced \$117,900. A spacious colonial
built in 1978 featuring 4 bedrooms,
2 1/2 baths, library and family room with
beautiful fireplace. Neutral decor.
Home backs to Commons area. Has
concrete patio & lovely landscaping.
Present mortgage is assumable with
very desirable interest rates.

CENTURY 21

OLD ORCHARD

OPEN SUNDAY 2-5
1100 4076 OLD DOMINION, N. of
Walnut Lake W. of Orchard Lake.
Large 4 bedroom colonial in
neighborhood of attractively decorated
colonial homes. Best value in West
Bloomfield. Rooms all generous in size.
Excellent financing options available.
\$119,900

CENTURY 21

EXECUTIVE TRANSFER SALES
851-4100

OPEN SUNDAY!
30 Year Land Contract terms. Modern
4 1/2 bedroom Brick Quad. Spacious
kitchen, with all the appliances.
Furnished library with bookcase, 2 1/2
family room with fireplace, central air,
excellent locations. Asking \$115,900.

CENTURY 21

MJL CORPORATE
TRANSFEREE SERVICE
851-6700

OPEN SUN. 2-5
ORCHARD CREST NORTH
6088 Kiev
Just reduced \$117,900. A spacious colonial
built in 1978 featuring 4 bedrooms,
2 1/2 baths, library and family room with
beautiful fireplace. Neutral decor.
Home backs to Commons area. Has
concrete patio & lovely landscaping.
Present mortgage is assumable with
very desirable interest rates.

CENTURY 21

MJL CORPORATE
TRANSFEREE SERVICE
851-6700

OPEN SUN. 2-5
ORCHARD CREST NORTH
6088 Kiev
Just reduced \$117,900. A spacious colonial
built in 1978 featuring 4 bedrooms,
2 1/2 baths, library and family room with
beautiful fireplace. Neutral decor.
Home backs to Commons area. Has
concrete patio & lovely landscaping.
Present mortgage is assumable with
very desirable interest rates.

CENTURY 21

EXECUTIVE TRANSFER SALES
851-4100

OPEN SUNDAY!
30 Year Land Contract terms. Modern
4 1/2 bedroom Brick Quad. Spacious
kitchen, with all the appliances.
Furnished library with bookcase, 2 1/2
family room with fireplace, central air,
excellent locations. Asking \$115,900.

CENTURY 21

MJL CORPORATE
TRANSFEREE SERVICE
851-6700

OPEN SUN. 2-5
ORCHARD CREST NORTH
6088 Kiev
Just reduced \$117,900. A spacious colonial
built in 1978 featuring 4 bedrooms,
2 1/2 baths, library and family room with
beautiful fireplace. Neutral decor.
Home backs to Commons area. Has
concrete patio & lovely landscaping.
Present mortgage is assumable with
very desirable interest rates.

CENTURY 21

EXECUTIVE TRANSFER SALES
851-4100

OPEN SUNDAY!
30 Year Land Contract terms. Modern
4 1/2 bedroom Brick Quad. Spacious
kitchen, with all the appliances.
Furnished library with bookcase, 2 1/2
family room with fireplace, central air,
excellent locations. Asking \$115,900.

CENTURY 21

MJL CORPORATE
TRANSFEREE SERVICE
851-6700

OPEN SUN. 2-5
ORCHARD CREST NORTH
6088 Kiev
Just reduced \$117,900. A spacious colonial
built in 1978 featuring 4 bedrooms,
2 1/2 baths, library and family room with
beautiful fireplace. Neutral decor.
Home backs to Commons area. Has
concrete patio & lovely landscaping.
Present mortgage is assumable with
very desirable interest rates.

LAKE LIVING

OPEN SAT. - SUN. 12-3
Magnificent new 4 bedroom home
among towering pines with privileges
on Upper Straits Lake. Designed for
gracious living & entertaining. Custom
features thru include deluxe custom
kitchen, Kohler fixtures & much more.
Priced at \$197,500. 4546 Rolling Pines
Ct., Pontiac Trail, W. of Halsted.
PINE LAKE HOMES 851-9117

304 Farmington Farmington Hills

ARCHITECTS' own 3 bedroom ranch.
over an acre of mature trees & fruit
trees. Great room, 2 fireplaces, beau-
tiful up-to-date kitchen and much more.
ASK FOR JERRY OR DIANA AN-
DREWS.

CENTURY 21

HOME CENTER
476-7000

FARMINGTON HILLS
Bet. 13th & 14th Mile, Hagerty & Halstead
FARMINGTON RIDGE SUB
FROM \$99,990

RANCH, QUADS, COLONIALS
3 and 4 bedroom brick, family room,
fireplace, air conditioning, dishwasher,
laundry room main floor, basement in-
cluded, under family room. Numerous
extras. Extremely scenic area.

ALSO, lots for sale to parties who want
to buy low - build later. From \$29,900
to \$35,000. \$1,000 down, 10% interest, 3
year land contract.

Open 1 to 5 PM, Sat., Sun.
Call 363-8307 or 851-2111

304 Farmington Farmington Hills

**ALL FARMINGTON HILLS
LAND CONTRACT**
Especially for the family - well main-
tained 3 bedroom brick ranch on spa-
cious 70 x 150 ft. lot for the kids. 1 1/2
baths, basement, swim club. Just listed
\$58,700.

LOWER RATES
Wow! Only \$62,500. Special below mar-
ket blended interest rate. Terrific brick
ranch, 19 ft. family room with fire-
place, central air, 1 1/2 baths, custom
kitchen, finished basement, 2 1/2 car
garage, covered patio, large lot with
trees.

LAND CONTRACT
Breath-taking ravine lot and affordable
terms. Brick split-level, short walk to
schools, parks and downtown 3 bed-
rooms, 2 baths, fireplace. 27 ft. family
room with walkout to picturesque set-
ting. \$75,500.

TERRIFIC TERMS
Gorgeous brick colonial on spacious
landscaped lot with excellent 4 bed-
rooms, 2 1/2 baths, family room with
fireplace, formal dining, 1st floor lanai,
2nd floor kitchen, den, terrace, car-
entry, garage, appliances, quick occu-
pancy. A special value at \$109,900.

CENTURY 21

OLD ORCHARD

304 Farmington Farmington Hills

SPRING SPECIAL only \$20,000
down on this 4 1/2 bedroom home. Fam-
ily room, fireplace, walk-out, well main-
tained 3 bedroom brick ranch on spa-
cious 70 x 150 ft. lot for the kids. 1 1/2
baths, basement, swim club. Just listed
\$58,700.

CENTURY 21

HOME CENTER
476-7000

304 Farmington Farmington Hills

SPRING SPECIAL only \$20,000
down on this 4 1/2 bedroom home. Fam-
ily room, fireplace, walk-out, well main-
tained 3 bedroom brick ranch on spa-
cious 70 x 150 ft. lot for the kids. 1 1/2
baths, basement, swim club. Just listed
\$58,700.

CENTURY 21

HOME CENTER
476-7000

304 Farmington Farmington Hills

SPRING SPECIAL only \$20,000
down on this 4 1/2 bedroom home. Fam-
ily room, fireplace, walk-out, well main-
tained 3 bedroom brick ranch on spa-
cious 70 x 150 ft. lot for the kids. 1 1/2
baths, basement, swim club. Just listed
\$58,700.

CENTURY 21

HOME CENTER
476-7000

304 Farmington Farmington Hills

SPRING SPECIAL only \$20,000
down on this 4 1/2 bedroom home. Fam-
ily room, fireplace, walk-out, well main-
tained 3 bedroom brick ranch on spa-
cious 70 x 150 ft. lot for the kids. 1 1/2
baths, basement, swim club. Just listed
\$58,700.

CENTURY 21

HOME CENTER
476-7000

304 Farmington Farmington Hills

SPRING SPECIAL only \$20,000
down on this 4 1/2 bedroom home. Fam-
ily room, fireplace, walk-out, well main-
tained 3 bedroom brick ranch on spa-
cious 70 x 150 ft. lot for the kids. 1 1/2
baths, basement, swim club. Just listed
\$58,700.

CENTURY 21

HOME CENTER
476-7000

304 Farmington Farmington Hills

SPRING SPECIAL only \$20,000
down on this 4 1/2 bedroom home. Fam-
ily room, fireplace, walk-out, well main-
tained 3 bedroom brick ranch on spa-
cious 70 x 150 ft. lot for the kids. 1 1/2
baths, basement, swim club. Just listed
\$58,700.

CENTURY 21

HOME CENTER
476-7000

304 Farmington Farmington Hills

SPRING SPECIAL only \$20,000
down on this 4 1/2 bedroom home. Fam-
ily room, fireplace, walk-out, well main-
tained 3 bedroom brick ranch on spa-
cious 70 x 150 ft. lot for the kids. 1 1/2
baths, basement, swim club. Just listed
\$58,700.

CENTURY 21

HOME CENTER
476-7000

304 Farmington Farmington Hills

SPRING SPECIAL only \$20,000
down on this 4 1/2 bedroom home. Fam-
ily room, fireplace, walk-out, well main-
tained 3 bedroom brick ranch on spa-
cious 70 x 150 ft. lot for the kids. 1 1/2
baths, basement, swim club. Just listed
\$58,700.

CENTURY 21

HOME CENTER
476-7000

304 Farmington Farmington Hills

SPRING SPECIAL only \$20,000
down on this 4 1/2 bedroom home. Fam-
ily room, fireplace, walk-out, well main-
tained 3 bedroom brick ranch on spa-
cious 70 x 150 ft. lot for the kids. 1 1/2
baths, basement, swim club. Just listed
\$58,700.

CENTURY 21

HOME CENTER
476-7000

305 Brighton-Hartland

BRIGHTON
Crown English Tudor on 10 beautifully
rolling acres. Features 3 fireplaces, 2
full baths, 2 1/2 baths, 3 car attached
garage, 2 car fire standing garage,
17x24 master bedroom, & all quality
extras you would expect to find in an
executive home. Call for a private
showing. \$199,900. 476-9130

Rymal Symes

306 Southfield-Lathrup
ABANDON YOUR HUNT - BY OWNER
Lathrup - Large custom 4 bedroom 3
bath Quad, 2 fireplaces, central air,
family room, rec room, 2 1/2 car garage.
Many extras. \$109,000. 9% L.C. or will
convey Equity Trade. L-956
559-4248 SHARE LISTINGS 642-1620

ADDISON
Beautiful ranch with charm throughout.
2 bedrooms, immaculate condition.
Natural fireplace, formal dining room.
Terms to suit. \$53,500.

CENTURY 21

TODAY 478-1040

305 Brighton-Hartland

BRIGHTON
Crown English Tudor on 10 beautifully
rolling acres. Features 3 fireplaces, 2
full baths, 2 1/2 baths, 3 car attached
garage, 2 car fire standing garage,
17x24 master bedroom, & all quality
extras you would expect to find in an
executive home. Call for a private
showing. \$199,900. 476-9130

Rymal Symes

306 Southfield-Lathrup
ABANDON YOUR HUNT - BY OWNER
Lathrup - Large custom 4 bedroom 3
bath Quad, 2 fireplaces, central air,
family room, rec room, 2 1/2 car garage.
Many extras. \$109,000. 9% L.C. or will
convey Equity Trade. L-956
559-4248 SHARE LISTINGS 642-1620

ADDISON
Beautiful ranch with charm throughout.
2 bedrooms, immaculate condition.
Natural fireplace, formal dining room.
Terms to suit. \$53,500.

CENTURY 21

TODAY 478-1040

305 Brighton-Hartland

BRIGHTON
Crown English Tudor on 10 beautifully
rolling acres. Features 3 fireplaces, 2
full baths, 2 1/2 baths, 3 car attached
garage, 2 car fire standing garage,
17x24 master bedroom, & all quality
extras you would expect to find in an
executive home. Call for a private
showing. \$199,900. 476-9130

Rymal Symes

306 Southfield-Lathrup
ABANDON YOUR HUNT - BY OWNER
Lathrup - Large custom 4 bedroom 3
bath Quad, 2 fireplaces, central air,
family room, rec room, 2 1/2 car garage.
Many extras. \$109,000. 9% L.C. or will
convey Equity Trade. L-956
559-4248 SHARE LISTINGS 642-1620

ADDISON
Beautiful ranch with charm throughout.
2 bedrooms, immaculate condition.
Natural fireplace, formal dining room.
Terms to suit. \$53,500.

CENTURY 21

TODAY 478-1040

305 Brighton-Hartland

BRIGHTON
Crown English Tudor on 10 beautifully
rolling acres. Features 3 fireplaces, 2
full baths, 2 1/2 baths, 3 car attached
garage, 2 car fire standing garage,
17x24 master bedroom, & all quality
extras you would expect to find in an
executive home. Call for a private
showing. \$199,900. 476-9130

Rymal Symes

306 Southfield-Lathrup
ABANDON YOUR HUNT - BY OWNER
Lathrup - Large custom 4 bedroom 3
bath Quad, 2 fireplaces, central air,
family room, rec room, 2 1/2 car garage.
Many extras. \$109,000. 9% L.C. or will
convey Equity Trade. L-956
559-4248 SHARE LISTINGS 642-1620

ADDISON
Beautiful ranch with charm throughout.
2 bedrooms, immaculate condition.
Natural fireplace, formal dining room.
Terms to suit. \$53,500.

CENTURY 21

TODAY 478-1040

305 Brighton-Hartland

BRIGHTON
Crown English Tudor on 10 beautifully
rolling acres. Features 3 fireplaces, 2
full baths, 2 1/2 baths, 3 car attached
garage, 2 car fire standing garage,
17x24 master bedroom, & all quality
extras you would expect to find in an
executive home. Call for a private
showing. \$199,900. 476-9130

Rymal Symes

306 Southfield-Lathrup
ABANDON YOUR HUNT - BY OWNER
Lathrup - Large custom 4 bedroom 3
bath Quad, 2 fireplaces, central air,
family room, rec room, 2 1/2 car garage.
Many extras. \$109,000. 9% L.C. or will
convey Equity Trade. L-956
559-4248 SHARE LISTINGS 642-1620

ADDISON
Beautiful ranch with charm throughout.
2 bedrooms, immaculate condition.
Natural fireplace, formal dining room.
Terms to suit. \$53,500.

CENTURY 21

TODAY 478-1040

305 Brighton-Hartland

BRIGHTON
Crown English Tudor on 10 beautifully
rolling acres. Features 3 fireplaces, 2
full baths, 2 1/2 baths, 3 car attached
garage, 2 car fire standing garage,
17x24 master bedroom, & all quality
extras you would expect to find in an
executive home. Call for a private
showing. \$199,900. 476-9130

Rymal Symes

306 Southfield-Lathrup
ABANDON YOUR HUNT - BY OWNER
Lathrup - Large custom 4 bedroom 3
bath Quad, 2 fireplaces, central air,
family room, rec room, 2 1/2 car garage.
Many extras. \$109,000. 9% L.C. or will
convey Equity Trade. L-956
559-4248 SHARE LISTINGS 642-1620

ADDISON
Beautiful ranch with charm throughout.
2 bedrooms, immaculate condition.
Natural fireplace, formal dining room.
Terms to suit. \$53,500.

CENTURY 21

TODAY 478-1040

305 Brighton-Hartland

BRIGHTON
Crown English Tudor on 10 beautifully
rolling acres. Features 3 fireplaces, 2
full baths, 2 1/2 baths, 3 car attached
garage, 2 car fire standing garage,
17x24 master bedroom, & all quality
extras you would expect to find in an
executive home. Call for a private
showing. \$199,900. 476-9130

Rymal Symes

306 Southfield-Lathrup
ABANDON YOUR HUNT - BY OWNER
Lathrup - Large custom 4 bedroom 3
bath Quad, 2 fireplaces, central air,
family room, rec room, 2 1/2 car garage.
Many extras. \$109,000. 9% L.C. or will
convey Equity Trade. L-956
559-4248 SHARE LISTINGS 642-1620

ADDISON
Beautiful ranch with charm throughout.
2 bedrooms, immaculate condition.
Natural fireplace, formal dining room.
Terms to suit. \$53,500.

CENTURY 21

TODAY 478-1040

305 Brighton-Hartland

BRIGHTON
Crown English Tudor on 10 beautifully
rolling acres. Features 3 fireplaces, 2
full baths, 2 1/2 baths, 3 car attached
garage, 2 car fire standing garage,
17x24 master bedroom, & all quality
extras you would expect to find in an
executive home. Call for a private
showing. \$199,900. 476-9130

Rymal Symes

306 Southfield-Lathrup
ABANDON YOUR HUNT - BY OWNER
Lathrup - Large custom 4 bedroom 3
bath Quad, 2 fireplaces, central air,
family room, rec room, 2 1/2 car garage.
Many extras. \$109,000. 9% L.C. or will
convey Equity Trade. L-956
559-4248 SHARE LISTINGS 642-1620

ADDISON
Beautiful ranch with charm throughout.
2 bedrooms, immaculate condition.
Natural fireplace, formal dining room.
Terms to suit. \$53,500.

CENTURY 21

TODAY 478-1040

305 Brighton-Hartland

BRIGHTON
Crown English Tudor on 10 beautifully
rolling acres. Features 3 fireplaces, 2
full baths, 2 1/2 baths, 3 car attached
garage, 2 car fire standing garage,
17x24 master bedroom, & all quality
extras you would expect to find in an
executive home. Call for a private
showing. \$199,900. 476-9130

Rymal Symes

306 Southfield-Lathrup
ABANDON YOUR HUNT - BY OWNER
Lathrup - Large custom 4 bedroom 3
bath Quad, 2 fireplaces, central air,
family room, rec room, 2 1/2 car garage.
Many extras. \$109,000. 9% L.C. or will
convey Equity Trade. L-956
559-4248 SHARE LISTINGS 642-1620

ADDISON
Beautiful ranch with charm throughout.
2 bedrooms, immaculate condition.
Natural fireplace, formal dining room.
Terms to suit. \$53,500.

CENTURY 21

TODAY 478-1040

305 Brighton-Hartland

BRIGHTON
Crown English Tudor on 10 beautifully
rolling acres. Features 3 fireplaces, 2
full baths, 2 1/2 baths, 3 car attached
garage, 2 car fire standing garage,
17x24 master bedroom, & all quality
extras you would expect to find in an
executive home. Call for a private
showing. \$199,900. 476-9130

Rymal Symes

306 Southfield-Lathrup
ABANDON YOUR HUNT - BY OWNER
Lathrup - Large custom 4 bedroom 3
bath Quad, 2 fireplaces, central air,
family room, rec room, 2 1/2 car garage.
Many extras. \$109,000. 9% L.C. or will
convey Equity Trade. L-956
559-4248 SHARE LISTINGS 642-1620

ADDISON
Beautiful ranch with charm throughout.
2 bedrooms, immaculate condition.
Natural fireplace, formal dining room.
Terms to suit. \$53,500.

CENTURY 21

TODAY 478-1040

306 Southfield-Lathrup

ASSUMPTION!
Assume with \$24,000 this 10 1/2% loan
a best value in Cranbrook Village.
OPEN SUN. 2-5, 2966 Brook Creek - S.
of 13 Mile, W. of Southfield. 5 bedroom
Colonial, 2 1/2 baths, family room, new
patio. Listed at \$82,500. H-11.

\$28,000 TO ASSUME 10% loan on sharp
3 bedroom ranch with beautiful rec
room and large extra bedroom in base-
ment. Mortgage also available with in-
terest below market rate in base-
ment. Near 10 Mile and Telegraph.
\$74,000. H-52

HANNETT, INC.
646-6200

LIBERAL LAND CONTRACT
Terms offered on this sunny
brick ranch with 3 bed-
rooms, 2 1/2 baths, family
room with fireplace, 1st floor
laundry, finished rec room,
2 1/2 car attached garage, Bir-
mingham schools. \$79,900.

EARL
KEIM
Realty North, Inc. 869-1300

306 Southfield-Lathrup

ASSUMPTION!
Assume with \$24,000 this 10 1/2% loan
a best value in Cranbrook Village.
OPEN SUN. 2-5, 2966 Brook Creek - S.
of 13 Mile, W. of Southfield. 5 bedroom
Colonial, 2 1/2 baths, family room, new
patio. Listed at \$82,500. H-11.

\$28,000 TO ASSUME 10% loan on sharp
3 bedroom ranch with beautiful rec
room and large extra bedroom in base-
ment. Mortgage also available with in-
terest below market rate in base-
ment. Near 10 Mile and Telegraph.
\$74,000. H-52

HANNETT, INC.
646-6200

LIBERAL LAND CONTRACT
Terms offered on this sunny
brick ranch with 3 bed-
rooms, 2 1/2 baths, family
room with fireplace, 1st floor
laundry, finished rec room,
2 1/2 car attached garage, Bir-
mingham schools. \$79,900.

EARL
KEIM
Realty North, Inc. 869-1300

306 Southfield-Lathrup

ASSUMPTION!
Assume with \$24,000 this 10 1/2% loan
a best value in Cranbrook Village.
OPEN SUN. 2-5, 2966 Brook Creek - S.
of 13 Mile, W. of Southfield. 5 bedroom
Colonial, 2 1/2 baths, family room, new
patio. Listed at \$82,500. H-11.

\$28,000 TO ASSUME 10% loan on sharp
3 bedroom ranch with beautiful rec
room and large extra bedroom in base-
ment. Mortgage also available with in-
terest below market rate in base-
ment. Near 10 Mile and Telegraph.
\$74,000. H-52

HANNETT, INC.
646-6200

LIBERAL LAND CONTRACT
Terms offered on this sunny
brick ranch with 3 bed-
rooms, 2 1/2 baths, family
room with fireplace, 1st floor
laundry, finished rec room,
2 1/2 car attached garage, Bir-
mingham schools. \$79,900.

EARL
KEIM
Realty North, Inc. 869-1300

306 Southfield-Lathrup

ASSUMPTION!
Assume with \$24,000 this 10 1/2% loan
a best value in Cranbrook Village.
OPEN SUN. 2-5, 2966 Brook Creek - S.
of 13 Mile, W. of Southfield. 5 bedroom
Colonial, 2 1/2 baths, family room, new
patio. Listed at \$82,500. H-11.

\$28,000 TO ASSUME 10% loan on sharp
3 bedroom ranch with beautiful rec
room and large extra bedroom in base-
ment. Mortgage also available with in-
terest below market rate in base-
ment. Near 10 Mile and Telegraph.
\$74,000. H-52

HANNETT, INC.
646-6200

LIBERAL LAND CONTRACT
Terms offered on this sunny
brick ranch with 3 bed-
rooms, 2 1/2 baths, family
room with fireplace, 1st floor
laundry, finished rec room,
2 1/2 car attached garage, Bir-
mingham schools. \$79,900.

EARL
KEIM
Realty North, Inc. 869-1300

306 Southfield-Lathrup

ASSUMPTION!
Assume with \$24,000 this 10 1/2% loan
a best value in Cranbrook Village.
OPEN SUN. 2-5, 2966 Brook Creek - S.
of 13 Mile, W. of Southfield. 5 bedroom
Colonial, 2 1/2 baths, family room, new
patio. Listed at \$82,500. H-11.

\$28,000 TO ASSUME 10% loan on sharp
3 bedroom ranch with beautiful rec
room and large extra bedroom in base-
ment. Mortgage also available with in-
terest below market rate in base-
ment. Near 10 Mile and Telegraph.
\$74,000. H-52

HANNETT, INC.
646-6200

LIBERAL LAND CONTRACT
Terms offered on this sunny
brick ranch with 3 bed-
rooms, 2 1/2 baths, family
room with fireplace, 1st floor
laundry, finished rec room,
2 1/2 car attached garage, Bir-
mingham schools. \$79,900.

EARL
KEIM
Realty North, Inc. 869-1300

306 Southfield-Lathrup

ASSUMPTION!
Assume with \$24,000 this 10 1/2% loan
a best value in Cranbrook Village.
OPEN SUN. 2-5, 2966 Brook Creek - S.
of 13 Mile, W. of Southfield. 5 bedroom
Colonial, 2 1/2 baths, family room, new
patio. Listed at \$82,500. H-11.

\$28,000 TO ASSUME 10% loan on sharp
3 bedroom ranch with beautiful rec
room and large extra bedroom in base-
ment. Mortgage also available with in-
terest below market rate in base-
ment. Near 10 Mile and Telegraph.
\$74,000. H-52

HANNETT, INC.
646-6200

LIBERAL LAND CONTRACT
Terms offered on this sunny
brick ranch with 3 bed-
rooms, 2 1/2 baths, family
room with fireplace, 1st floor
laundry, finished rec room,
2 1/2 car attached garage, Bir-
mingham schools. \$79,900.

EARL
KEIM
Realty North, Inc. 869-1300

306 Southfield-Lathrup

ASSUMPTION!
Assume with \$24,000 this 10 1/2% loan
a best value in Cranbrook Village.
OPEN SUN. 2-5, 2966 Brook Creek - S.
of 13 Mile, W. of Southfield. 5 bedroom
Colonial, 2 1/2 baths, family room, new
patio. Listed at \$82,500. H-11.

\$28,000 TO ASSUME 10% loan on sharp
3 bedroom ranch with beautiful rec
room and large extra bedroom in base-
ment. Mortgage also available with in-
terest below market rate in base-
ment. Near 10 Mile and Telegraph.
\$74,000. H-52

HANNETT, INC.
646-6200

LIBERAL LAND CONTRACT
Terms offered on this sunny
brick ranch with 3 bed-
rooms, 2 1/2 baths, family
room with fireplace, 1st floor
laundry, finished rec room,
2 1/2 car attached garage, Bir-
mingham schools. \$79,900.

EARL
KEIM
Realty North, Inc. 869-1300

306 Southfield-Lathrup

ASSUMPTION!
Assume with \$24,000 this 10 1/2% loan
a best value in Cranbrook Village.
OPEN SUN. 2-5, 2966 Brook Creek - S.
of 13 Mile, W. of Southfield. 5 bedroom
Colonial, 2 1/2 baths, family room, new
patio. Listed at \$82,500. H-11.

\$28,000 TO ASSUME 10% loan on sharp
3 bedroom ranch with beautiful rec
room and large extra bedroom in base-
ment. Mortgage also available with in-
terest below market rate in base-
ment. Near 10 Mile and Telegraph.
\$74,000. H-52

HANNETT, INC.
646-6200

LIBERAL LAND CONTRACT
Terms offered on this sunny
brick ranch with 3 bed-
rooms, 2 1/2 baths, family
room with fireplace, 1st floor
laundry, finished rec room,
2 1/2 car attached garage, Bir-
mingham schools. \$79,900.

EARL
KEIM
Realty North, Inc. 869-1300

306 Southfield-Lathrup

ASSUMPTION!
Assume with \$24,000 this 10 1/2% loan
a best value in Cranbrook

308 Rochester-Troy
ASSUME AT 4% - TROY
4 bedroom colonial, winding staircase, 2 1/2 baths, living, dining & family room, fireplace, approximately 2400 sq ft. Immediate possession. Many extras \$95,000. Owner 878-1775

308 Rochester-Troy
OPEN SUN 1-4 PM
6895 Dublin Park, Troy N. of Lake Charwood, E. of Adams.

309 Royal Oak-Oak Park
Huntington Woods
OAK PARK
Spacious 3 bedroom brick ranch with 2 1/2 baths, Master Suite, 1218 living room, large kitchen with built-in, family room, central air, immaculate home. Assumed 9% Mortgage. \$59,900.

311 Homes For Sale
Oakland County
SAVE \$5900
Land contract, 2 1/2 bedrooms, 2 1/2 baths. Completely remodeled, 3 down payments, full basement, fireplace, large lot. Why pay \$350,000 commission? Buy direct from owner. \$74,920 or \$28,644.

322 Condominiums
For Sale
NORTHVILLE, Country Place, 2 bedroom ranch, granite appliances and draperies. Financing available \$71,900. After 5.30 PM. 646-9573

322 Condominiums
For Sale
PLYMOUTH - Wedgewood Condos. Condo, 3 bedrooms, 2 1/2 baths, 2 fireplaces, finished basement, 10% land contract. \$87,500. 729-8111

323 Livingston County
LAND CONTRACT WITH LOW DOWN PAYMENT, Howell-Country living at its best. 5 bedrooms, excellent condition, 1 1/2 acres. Many mature trees. \$36,900. Days, 421-9504. Even, 517-545-3549

332 Mobile Homes
For Sale
MOBILE HOMES
IN PARKS
CHILD LAKE ESTATES
STRATFORD VILLAGE
Single wide expands, double wide
MCDONALD MOBILE HOMES INC
685-9895

AVON/ROCHESTER
SUPERB SETTING
Quick possession. Handsome Colonial with fieldstone trim, ravine setting. Ready for color selection.

LAVERNE EADY
& ASSOCIATES, INC.
626-4711 227-4744
QUILT VILLAGE SETTING
Lovely 3 bedroom, 1 1/2 bath, somewhat secluded ranch located Goodrich. This Fall you can watch the geese land on Mill Pond from your deck and allow your family to enjoy the yard in which to roam. A house that is priced to sell for only \$69,900.

CENTURY 21
M/J CORPORATE
TRANSFER SERVICE
851-6700
ROYAL OAK Vinetta Blvd. 3 bedroom ranch with professionally landscaped lot. Large family room with fireplace, \$98,500.

320 Other Suburban
Homes For Sale
RURAL - CITY
Large lot, simple assumption or wrap around land contract. Hardwood floors, wood deck, oven, range and refrigerator stay, 3 bedrooms, 1 1/2 baths. Only \$53,500. Ask for: BRAD WERNER Century 21 Gold House Realtors 459-6000

ROBERT BAKE
Realtors
453-8200
PLYMOUTH LANDING
Coveted 2 bedroom End Unit Townhouse, 1 1/2 baths, large utility room, ample storage. Beautifully appointed, many upgraded features. Perfect for Singles or Newlyweds! Get a lot more for your money than Rent Receipts! Don't Wait! Call Now! Only \$45,900.

CONDOMINIUM
REALTY
559-3800
OPEN SAT & SUN 1-5
1/2 mi. S. of Hwy 24, 2119 S. Franklin Rd., Franklin Orchard, Southfield, 2 bedroom, 1 1/2 bath, townhouses Country kitchen, walkout patio, full basement, covered parking. Land Contract terms. \$115,900. Call at 815.

332 Duplexes For Sale
DUPLEX in Brighton 2 bedroom ranch. Basement & garage. Excellent. Built in 1977. Assumed at 8 1/2% or land contract \$83,900. 595-9897

332 Mobile Homes
For Sale
MOBILE HOME 1 bedroom including attached utility & lawn shed. Farmington area. \$3,000. Available immediately. Call after 5:30pm. 534-7100

Chamberlain
COUNTRY LIKE Ranch 3 bedrooms, 2 full baths, nice size breezeway, fireplace living room, fenced patio area and a small barn for horses if you wish \$67,900.

FAMILY LIVING
At its best in this 2200 sq. ft., 2 story, Master bed home. 3 bedrooms, 2 full baths. View the lake when you awake in your large master suite. Relax in the evening around the stone fireplace in the family room. Easy access to 1-75, near Clarkston. \$124,900.

DESIGNER HOME
WITH SIMPLE ASSUMPTION
Every square inch of this Royal Oak Shire home has been planned to enhance a modern life style. The second floor master suite is a knock out, the fireplace, formal dining room and large deck rapped around the house by a designer for a superb setting for stylish entertaining. 3 bedrooms, 2 full baths, full basement, 2 1/2 car heated garage, by appointment.

320 Other Suburban
Homes For Sale
RURAL - CITY
Large lot, simple assumption or wrap around land contract. Hardwood floors, wood deck, oven, range and refrigerator stay, 3 bedrooms, 1 1/2 baths. Only \$53,500. Ask for: BRAD WERNER Century 21 Gold House Realtors 459-6000

SPACIOUS
Bloomfield Hills Condo, complete with fireplace 2 bedrooms 2 baths & a very own 700 sq. ft. basement. Open & airy with good traffic pattern. Low maintenance. Includes heat \$85,900.

CONDOMINIUM
REALTY
559-3800
OPEN SAT & SUN 2-6
25115 GREENBROOKE, SOUTHFIELD Executive condo with 3 bedrooms, 2 1/2 baths, central air, finished dining, brick fireplace, basement, wood paneling. Simple assumption and Land Contract terms \$83,499.

330 Apts. For Sale
Don't miss this opportunity! A choice of two newly listed tremendous investment properties. 2 bed, 1 bath. Call for details. 626-8700

332 Mobile Homes
For Sale
BARON mobile home in Highland 12x65 with 7x13 expand \$9000 or best offer Security patrol & guard Adult section Call evenings 498-2636

Chamberlain
MODEL LIKE COLONIAL has 4 bedrooms, 2 1/2 baths, large fireplace family room, professionally landscaped yard with sprinkling system and all backs to wooded area \$109,900

Snyder Kinney & Bennett
GALLERY
OF HOMES
651-6100
ROCHESTER - GROSE PINES
Immaculate 2950 sq. ft. 4 bedroom colonial with 2 1/2 baths, granite counter, wooded lot, decorator interior, burglar alarm, sprinkler, plus other extras too numerous to mention. \$299,900. Assumed mortgage. Open Sun 1-5 PM 1850 Kilcon Ct. 652-7200

310 Union Lake
Commerc
Fox Lake Privileges
UNION LAKE AREA
Super sharp rough sawn cedar, 3 bedroom ranch on professionally landscaped 2 full baths, full basement, carpeted, full kitchen, 2 1/2 car heated garage, by appointment.

320 Other Suburban
Homes For Sale
RURAL - CITY
Large lot, simple assumption or wrap around land contract. Hardwood floors, wood deck, oven, range and refrigerator stay, 3 bedrooms, 1 1/2 baths. Only \$53,500. Ask for: BRAD WERNER Century 21 Gold House Realtors 459-6000

ROBERT BAKE
Realtors
453-8200
PLYMOUTH LANDING
Coveted 2 bedroom End Unit Townhouse, 1 1/2 baths, large utility room, ample storage. Beautifully appointed, many upgraded features. Perfect for Singles or Newlyweds! Get a lot more for your money than Rent Receipts! Don't Wait! Call Now! Only \$45,900.

CONDOMINIUM
REALTY
559-3800
OPEN SAT & SUN 2-6
25115 GREENBROOKE, SOUTHFIELD Executive condo with 3 bedrooms, 2 1/2 baths, central air, finished dining, brick fireplace, basement, wood paneling. Simple assumption and Land Contract terms \$83,499.

330 Apts. For Sale
Don't miss this opportunity! A choice of two newly listed tremendous investment properties. 2 bed, 1 bath. Call for details. 626-8700

332 Mobile Homes
For Sale
BARON mobile home in Highland 12x65 with 7x13 expand \$9000 or best offer Security patrol & guard Adult section Call evenings 498-2636

Chamberlain
689-8900
COLONIAL - Land Contract, 1 1/2 down 4 bedrooms, 2 1/2 baths, family room, fireplace, basement, 2 car attached garage. Newer \$101,000. Troy 338-9842

ROYAL OAK Vinetta Blvd. 3 bedroom ranch with professionally landscaped lot. Large family room with fireplace, \$98,500.

DESIGNER HOME
WITH SIMPLE ASSUMPTION
Every square inch of this Royal Oak Shire home has been planned to enhance a modern life style. The second floor master suite is a knock out, the fireplace, formal dining room and large deck rapped around the house by a designer for a superb setting for stylish entertaining. 3 bedrooms, 2 full baths, full basement, 2 1/2 car heated garage, by appointment.

320 Other Suburban
Homes For Sale
RURAL - CITY
Large lot, simple assumption or wrap around land contract. Hardwood floors, wood deck, oven, range and refrigerator stay, 3 bedrooms, 1 1/2 baths. Only \$53,500. Ask for: BRAD WERNER Century 21 Gold House Realtors 459-6000

ROBERT BAKE
Realtors
453-8200
PLYMOUTH LANDING
Coveted 2 bedroom End Unit Townhouse, 1 1/2 baths, large utility room, ample storage. Beautifully appointed, many upgraded features. Perfect for Singles or Newlyweds! Get a lot more for your money than Rent Receipts! Don't Wait! Call Now! Only \$45,900.

CONDOMINIUM
REALTY
559-3800
OPEN SAT & SUN 2-6
25115 GREENBROOKE, SOUTHFIELD Executive condo with 3 bedrooms, 2 1/2 baths, central air, finished dining, brick fireplace, basement, wood paneling. Simple assumption and Land Contract terms \$83,499.

330 Apts. For Sale
Don't miss this opportunity! A choice of two newly listed tremendous investment properties. 2 bed, 1 bath. Call for details. 626-8700

332 Mobile Homes
For Sale
BARON mobile home in Highland 12x65 with 7x13 expand \$9000 or best offer Security patrol & guard Adult section Call evenings 498-2636

Country Setting
4 bedroom ranch on 2.9 acres - close to town. Well maintained home, full basement, maintenance free exterior. Rochester schools. Simple assumption or blend available \$87,900 (40 PR).

ROYAL OAK Vinetta Blvd. 3 bedroom ranch with professionally landscaped lot. Large family room with fireplace, \$98,500.

DESIGNER HOME
WITH SIMPLE ASSUMPTION
Every square inch of this Royal Oak Shire home has been planned to enhance a modern life style. The second floor master suite is a knock out, the fireplace, formal dining room and large deck rapped around the house by a designer for a superb setting for stylish entertaining. 3 bedrooms, 2 full baths, full basement, 2 1/2 car heated garage, by appointment.

320 Other Suburban
Homes For Sale
RURAL - CITY
Large lot, simple assumption or wrap around land contract. Hardwood floors, wood deck, oven, range and refrigerator stay, 3 bedrooms, 1 1/2 baths. Only \$53,500. Ask for: BRAD WERNER Century 21 Gold House Realtors 459-6000

ROBERT BAKE
Realtors
453-8200
PLYMOUTH LANDING
Coveted 2 bedroom End Unit Townhouse, 1 1/2 baths, large utility room, ample storage. Beautifully appointed, many upgraded features. Perfect for Singles or Newlyweds! Get a lot more for your money than Rent Receipts! Don't Wait! Call Now! Only \$45,900.

CONDOMINIUM
REALTY
559-3800
OPEN SAT & SUN 2-6
25115 GREENBROOKE, SOUTHFIELD Executive condo with 3 bedrooms, 2 1/2 baths, central air, finished dining, brick fireplace, basement, wood paneling. Simple assumption and Land Contract terms \$83,499.

330 Apts. For Sale
Don't miss this opportunity! A choice of two newly listed tremendous investment properties. 2 bed, 1 bath. Call for details. 626-8700

332 Mobile Homes
For Sale
BARON mobile home in Highland 12x65 with 7x13 expand \$9000 or best offer Security patrol & guard Adult section Call evenings 498-2636

Century 21
Town & Country 652-8000
Great Terms Available
On this home that features 3 or 4 bedrooms, 1 1/2 baths, family room, fireplace & lovely floor plan. Beautifully landscaped & move-in condition. Assumption or land contract \$77,900.

ROYAL OAK Vinetta Blvd. 3 bedroom ranch with professionally landscaped lot. Large family room with fireplace, \$98,500.

DESIGNER HOME
WITH SIMPLE ASSUMPTION
Every square inch of this Royal Oak Shire home has been planned to enhance a modern life style. The second floor master suite is a knock out, the fireplace, formal dining room and large deck rapped around the house by a designer for a superb setting for stylish entertaining. 3 bedrooms, 2 full baths, full basement, 2 1/2 car heated garage, by appointment.

320 Other Suburban
Homes For Sale
RURAL - CITY
Large lot, simple assumption or wrap around land contract. Hardwood floors, wood deck, oven, range and refrigerator stay, 3 bedrooms, 1 1/2 baths. Only \$53,500. Ask for: BRAD WERNER Century 21 Gold House Realtors 459-6000

ROBERT BAKE
Realtors
453-8200
PLYMOUTH LANDING
Coveted 2 bedroom End Unit Townhouse, 1 1/2 baths, large utility room, ample storage. Beautifully appointed, many upgraded features. Perfect for Singles or Newlyweds! Get a lot more for your money than Rent Receipts! Don't Wait! Call Now! Only \$45,900.

CONDOMINIUM
REALTY
559-3800
OPEN SAT & SUN 2-6
25115 GREENBROOKE, SOUTHFIELD Executive condo with 3 bedrooms, 2 1/2 baths, central air, finished dining, brick fireplace, basement, wood paneling. Simple assumption and Land Contract terms \$83,499.

330 Apts. For Sale
Don't miss this opportunity! A choice of two newly listed tremendous investment properties. 2 bed, 1 bath. Call for details. 626-8700

332 Mobile Homes
For Sale
BARON mobile home in Highland 12x65 with 7x13 expand \$9000 or best offer Security patrol & guard Adult section Call evenings 498-2636

CRANBROOK
ASSOC. INC., REALTORS
645-5790
GREAT VALUES
CHARNWOOD colonial, LC Professionally decorated home with gourmet kitchen with extensive built ins, walk out lower level finished rec room with more, time to see & buy. \$119,900. 689-3600

ROYAL OAK Vinetta Blvd. 3 bedroom ranch with professionally landscaped lot. Large family room with fireplace, \$98,500.

DESIGNER HOME
WITH SIMPLE ASSUMPTION
Every square inch of this Royal Oak Shire home has been planned to enhance a modern life style. The second floor master suite is a knock out, the fireplace, formal dining room and large deck rapped around the house by a designer for a superb setting for stylish entertaining. 3 bedrooms, 2 full baths, full basement, 2 1/2 car heated garage, by appointment.

320 Other Suburban
Homes For Sale
RURAL - CITY
Large lot, simple assumption or wrap around land contract. Hardwood floors, wood deck, oven, range and refrigerator stay, 3 bedrooms, 1 1/2 baths. Only \$53,500. Ask for: BRAD WERNER Century 21 Gold House Realtors 459-6000

ROBERT BAKE
Realtors
453-8200
PLYMOUTH LANDING
Coveted 2 bedroom End Unit Townhouse, 1 1/2 baths, large utility room, ample storage. Beautifully appointed, many upgraded features. Perfect for Singles or Newlyweds! Get a lot more for your money than Rent Receipts! Don't Wait! Call Now! Only \$45,900.

CONDOMINIUM
REALTY
559-3800
OPEN SAT & SUN 2-6
25115 GREENBROOKE, SOUTHFIELD Executive condo with 3 bedrooms, 2 1/2 baths, central air, finished dining, brick fireplace, basement, wood paneling. Simple assumption and Land Contract terms \$83,499.

330 Apts. For Sale
Don't miss this opportunity! A choice of two newly listed tremendous investment properties. 2 bed, 1 bath. Call for details. 626-8700

332 Mobile Homes
For Sale
BARON mobile home in Highland 12x65 with 7x13 expand \$9000 or best offer Security patrol & guard Adult section Call evenings 498-2636

CRANBROOK
ASSOC. INC., REALTORS
645-5790
GREAT VALUES
CHARNWOOD colonial, LC Professionally decorated home with gourmet kitchen with extensive built ins, walk out lower level finished rec room with more, time to see & buy. \$119,900. 689-3600

ROYAL OAK Vinetta Blvd. 3 bedroom ranch with professionally landscaped lot. Large family room with fireplace, \$98,500.

DESIGNER HOME
WITH SIMPLE ASSUMPTION
Every square inch of this Royal Oak Shire home has been planned to enhance a modern life style. The second floor master suite is a knock out, the fireplace, formal dining room and large deck rapped around the house by a designer for a superb setting for stylish entertaining. 3 bedrooms, 2 full baths, full basement, 2 1/2 car heated garage, by appointment.

320 Other Suburban
Homes For Sale
RURAL - CITY
Large lot, simple assumption or wrap around land contract. Hardwood floors, wood deck, oven, range and refrigerator stay, 3 bedrooms, 1 1/2 baths. Only \$53,500. Ask for: BRAD WERNER Century 21 Gold House Realtors 459-6000

ROBERT BAKE
Realtors
453-8200
PLYMOUTH LANDING
Coveted 2 bedroom End Unit Townhouse, 1 1/2 baths, large utility room, ample storage. Beautifully appointed, many upgraded features. Perfect for Singles or Newlyweds! Get a lot more for your money than Rent Receipts! Don't Wait! Call Now! Only \$45,900.

CONDOMINIUM
REALTY
559-3800
OPEN SAT & SUN 2-6
25115 GREENBROOKE, SOUTHFIELD Executive condo with 3 bedrooms, 2 1/2 baths, central air, finished dining, brick fireplace, basement, wood paneling. Simple assumption and Land Contract terms \$83,499.

330 Apts. For Sale
Don't miss this opportunity! A choice of two newly listed tremendous investment properties. 2 bed, 1 bath. Call for details. 626-8700

332 Mobile Homes
For Sale
BARON mobile home in Highland 12x65 with 7x13 expand \$9000 or best offer Security patrol & guard Adult section Call evenings 498-2636

CRANBROOK
ASSOC. INC., REALTORS
645-5790
GREAT VALUES
CHARNWOOD colonial, LC Professionally decorated home with gourmet kitchen with extensive built ins, walk out lower level finished rec room with more, time to see & buy. \$119,900. 689-3600

ROYAL OAK Vinetta Blvd. 3 bedroom ranch with professionally landscaped lot. Large family room with fireplace, \$98,500.

DESIGNER HOME
WITH SIMPLE ASSUMPTION
Every square inch of this Royal Oak Shire home has been planned to enhance a modern life style. The second floor master suite is a knock out, the fireplace, formal dining room and large deck rapped around the house by a designer for a superb setting for stylish entertaining. 3 bedrooms, 2 full baths, full basement, 2 1/2 car heated garage, by appointment.

320 Other Suburban
Homes For Sale
RURAL - CITY
Large lot, simple assumption or wrap around land contract. Hardwood floors, wood deck, oven, range and refrigerator stay, 3 bedrooms, 1 1/2 baths. Only \$53,500. Ask for: BRAD WERNER Century 21 Gold House Realtors 459-6000

ROBERT BAKE
Realtors
453-8200
PLYMOUTH LANDING
Coveted 2 bedroom End Unit Townhouse, 1 1/2 baths, large utility room, ample storage. Beautifully appointed, many upgraded features. Perfect for Singles or Newlyweds! Get a lot more for your money than Rent Receipts! Don't Wait! Call Now! Only \$45,900.

CONDOMINIUM
REALTY
559-3800
OPEN SAT & SUN 2-6
25115 GREENBROOKE, SOUTHFIELD Executive condo with 3 bedrooms, 2 1/2 baths, central air, finished dining, brick fireplace, basement, wood paneling. Simple assumption and Land Contract terms \$83,499.

330 Apts. For Sale
Don't miss this opportunity! A choice of two newly listed tremendous investment properties. 2 bed, 1 bath. Call for details. 626-8700

332 Mobile Homes
For Sale
BARON mobile home in Highland 12x65 with 7x13 expand \$9000 or best offer Security patrol & guard Adult section Call evenings 498-2636

CRANBROOK
ASSOC. INC., REALTORS
645-5790
GREAT VALUES
CHARNWOOD colonial, LC Professionally decorated home with gourmet kitchen with extensive built ins, walk out lower level finished rec room with more, time to see & buy. \$119,900. 689-3600

ROYAL OAK Vinetta Blvd. 3 bedroom ranch with professionally landscaped lot. Large family room with fireplace, \$98,500.

DESIGNER HOME
WITH SIMPLE ASSUMPTION
Every square inch of this Royal Oak Shire home has been planned to enhance a modern life style. The second floor master suite is a knock out, the fireplace, formal dining room and large deck rapped around the house by a designer for a superb setting for stylish entertaining. 3 bedrooms, 2 full baths, full basement, 2 1/2 car heated garage, by appointment.

320 Other Suburban
Homes For Sale
RURAL - CITY
Large lot, simple assumption or wrap around land contract. Hardwood floors, wood deck, oven, range and refrigerator stay, 3 bedrooms, 1 1/2 baths. Only \$53,500. Ask for: BRAD WERNER Century 21 Gold House Realtors 459-6000

ROBERT BAKE
Realtors
453-8200
PLYMOUTH LANDING
Coveted 2 bedroom End Unit Townhouse, 1 1/2 baths, large utility room, ample storage. Beautifully appointed, many upgraded features. Perfect for Singles or Newlyweds! Get a lot more for your money than Rent Receipts! Don't Wait! Call Now! Only \$45,900.

CONDOMINIUM
REALTY
559-3800
OPEN SAT & SUN 2-6
25115 GREENBROOKE, SOUTHFIELD Executive condo with 3 bedrooms, 2 1/2 baths, central air, finished dining, brick fireplace, basement, wood paneling. Simple assumption and Land Contract terms \$83,499.

330 Apts. For Sale
Don't miss this opportunity! A choice of two newly listed tremendous investment properties. 2 bed, 1 bath. Call for details. 626-8700

332 Mobile Homes
For Sale
BARON mobile home in Highland 12x65 with 7x13 expand \$9000 or best offer Security patrol & guard Adult section Call evenings 498-2636

CRANBROOK
ASSOC. INC., REALTORS
645-5790
GREAT VALUES
CHARNWOOD colonial, LC Professionally decorated home with gourmet kitchen with extensive built ins, walk out lower level finished rec room with more, time to see & buy. \$119,900. 689-3600

ROYAL OAK Vinetta Blvd. 3 bedroom ranch with professionally landscaped lot. Large family room with fireplace, \$98,500.

DESIGNER HOME
WITH SIMPLE ASSUMPTION
Every square inch of this Royal Oak Shire home has been planned to enhance a modern life style. The second floor master suite is a knock out, the fireplace, formal dining room and large deck rapped around the house by a designer for a superb setting for stylish entertaining. 3 bedrooms, 2 full baths, full basement, 2 1/2 car heated garage, by appointment.

320 Other Suburban
Homes For Sale
RURAL - CITY
Large lot, simple assumption or wrap around land contract. Hardwood floors, wood deck, oven, range and refrigerator stay, 3 bedrooms, 1 1/2 baths. Only \$53,500. Ask for: BRAD WERNER Century 21 Gold House Realtors 459-6000

ROBERT BAKE
Realtors
453-8200
PLYMOUTH LANDING
Coveted 2 bedroom End Unit Townhouse, 1 1/2 baths, large utility room, ample storage. Beautifully appointed, many upgraded features. Perfect for Singles or Newlyweds! Get a lot more for your money than Rent Receipts! Don't Wait! Call Now! Only \$45,900.

CONDOMINIUM
REALTY
559-3800
OPEN SAT & SUN 2-6
25115 GREENBROOKE, SOUTHFIELD Executive condo with 3 bedrooms, 2 1/2 baths, central air, finished dining, brick fireplace, basement, wood paneling. Simple assumption and Land Contract terms \$83,499.

330 Apts. For Sale
Don't miss this opportunity! A choice of two newly listed tremendous investment properties. 2 bed, 1 bath. Call for details. 626-8700

332 Mobile Homes
For Sale
BARON mobile home in Highland 12x65 with 7x13 expand \$9000 or best offer Security patrol & guard Adult section Call evenings 498-2636

CRANBROOK
ASSOC. INC., REALTORS
645-5790
GREAT VALUES
CHARNWOOD colonial, LC Professionally decorated home with gourmet kitchen with extensive built ins, walk out lower level finished rec room with more, time to see & buy. \$119,900. 689-3600

ROYAL OAK Vinetta Blvd. 3 bedroom ranch with professionally landscaped lot. Large family room with fireplace, \$98,500.

DESIGNER HOME
WITH SIMPLE ASSUMPTION
Every square inch of this Royal Oak Shire home has been planned to enhance a modern life style. The second floor master suite is a knock out, the fireplace, formal dining room and large deck rapped around the house by a designer for a superb setting for stylish entertaining. 3 bedrooms, 2 full baths, full basement, 2 1/2 car heated garage, by appointment.

320 Other Suburban
Homes For Sale
RURAL - CITY
Large lot, simple assumption or wrap around land contract. Hardwood floors, wood deck, oven, range and refrigerator stay, 3 bedrooms, 1 1/2 baths. Only \$53,500. Ask for: BRAD WERNER Century 21 Gold House Realtors 459-6000

ROBERT BAKE
Realtors
453-8200
PLYMOUTH LANDING
Coveted 2 bedroom End Unit Townhouse, 1 1/2 baths, large utility room, ample storage. Beautifully appointed, many upgraded features. Perfect for Singles or Newlyweds! Get a lot more for your money than Rent Receipts! Don't Wait! Call Now! Only \$45,900.

CONDOMINIUM
REALTY
559-3800
OPEN SAT & SUN 2-6
25115 GREENBROOKE, SOUTHFIELD Executive condo with 3 bedrooms, 2 1/2 baths, central air, finished dining, brick fireplace, basement, wood paneling. Simple assumption and Land Contract terms \$83,499.

330 Apts. For Sale
Don't miss this opportunity! A choice of two newly listed tremendous investment properties. 2 bed, 1 bath. Call for details. 626-8700

332 Mobile Homes
For Sale
BARON mobile home in Highland 12x65 with 7x13 expand \$9000 or best offer Security patrol & guard Adult section Call evenings 498-2636

CRANBROOK
ASSOC. INC., REALTORS
645-5790
GREAT VALUES
CHARNWOOD colonial, LC Professionally decorated home with gourmet kitchen with extensive built ins, walk out lower level finished rec room with more, time to see & buy. \$119,900. 689-3600

ROYAL OAK Vinetta Blvd. 3 bedroom ranch with professionally landscaped lot. Large family room with fireplace, \$98,500.

DESIGNER HOME
WITH SIMPLE ASSUMPTION
Every square inch of this Royal Oak Shire home has been planned to enhance a modern life style. The second floor master suite is a knock out, the fireplace, formal dining room and large deck rapped around the house by a designer for a superb setting for stylish entertaining. 3 bedrooms, 2 full baths, full basement, 2 1/2 car heated garage, by appointment.

320 Other Suburban
Homes For Sale
RURAL - CITY
Large lot, simple assumption or wrap around land contract. Hardwood floors, wood deck, oven, range and refrigerator stay, 3 bedrooms, 1 1/2 baths. Only \$53,500. Ask for: BRAD WERNER Century 21 Gold House Realtors 459-6000

ROBERT BAKE
Realtors
453-8200
PLYMOUTH LANDING
Coveted 2 bedroom End Unit Townhouse, 1 1/2 baths, large utility room, ample storage. Beautifully appointed, many upgraded features. Perfect for Singles or Newlyweds! Get a lot more for your money than Rent Receipts! Don't Wait! Call Now! Only \$45,900.

CONDOMINIUM
REALTY
559-3800
OPEN SAT & SUN 2-6
25115 GREENBROOKE, SOUTHFIELD Executive condo with 3 bedrooms, 2 1/2 baths, central air, finished dining, brick fireplace, basement, wood paneling. Simple assumption and Land Contract terms \$83,499.

330 Apts. For Sale
Don't miss this opportunity! A choice of two newly listed tremendous investment properties. 2 bed, 1 bath. Call for details. 626-8700

332 Mobile Homes
For Sale
BARON mobile home in Highland 12x65 with 7x13 expand \$9000 or best offer Security patrol & guard Adult section Call evenings 498-2636

CRANBROOK
ASSOC. INC., REALTORS
645-5790
GREAT VALUES
CHARNWOOD colonial, LC Professionally decorated home with gourmet kitchen with extensive built ins, walk out lower level finished rec room with more, time to see & buy. \$119,900. 689-3600

ROYAL OAK Vinetta Blvd. 3 bedroom ranch with professionally landscaped lot. Large family room with fireplace, \$98,500.

DESIGNER HOME
WITH SIMPLE ASSUMPTION
Every square inch of this Royal Oak Shire home has been planned to enhance a modern life style. The second floor master suite is a knock out, the fireplace, formal dining room and large deck rapped around the house by a designer for a superb setting for stylish entertaining. 3 bedrooms, 2 full baths, full basement, 2 1/2 car heated garage, by appointment.

320 Other Suburban
Homes For Sale
RURAL - CITY
Large lot, simple assumption or wrap around land contract. Hardwood floors, wood deck, oven, range and refrigerator stay, 3 bedrooms, 1 1/2 baths. Only \$53,500. Ask for: BRAD WERNER Century 21 Gold House Realtors 459-6000

ROBERT BAKE
Realtors
453-8200
PLYMOUTH LANDING
Coveted 2 bedroom End Unit Townhouse, 1 1/2 baths, large utility room, ample storage. Beautifully appointed, many upgraded features. Perfect for Singles or Newlyweds! Get a lot more for your money than Rent Receipts! Don't Wait! Call Now! Only \$45,900.

CONDOMINIUM
REALTY
559-3800
OPEN SAT & SUN 2-6
25115 GREENBROOKE, SOUTHFIELD Executive condo with 3 bedrooms, 2 1/2 baths, central air, finished dining, brick fireplace, basement, wood

338 Lots & Acreage For Sale
BLOOMFIELD HILLS TWP. EAST
SOUTH OF LONG LAKE...
ONE HALF ACRE FULLY IMPROVED LOTS

338 Lots & Acreage For Sale
WANTED: Reputable builder with
acres in Plymouth area to build a
single home...

344 Country Homes
PRESTIGE area of Milford Georgian
colonial on 12 rolling wooded acres
with paved private road...

356 Investment Property For Sale
COMMERCIAL TWP. 360ft. on Welch
Rd. 11 acres with 2 family income
homes...

362 Real Estate Wanted
BIRMINGHAM WANTED. Family desires
3-4 bedroom, 1 1/2-2 bath home in
Birmingham...

400 Apartments For Rent
BEDFORD SQUARE APTS.
CANTON
Near Ford Rd. & 1275 Lovely, luxury
apartments...

400 Apartments For Rent
BLOOMFIELD LAKES APARTMENTS
Why buy furniture at this time when we
have beautifully furnished apartments
available...

400 Apartments For Rent
CHURCHILL SQUARE-Troy's finest 1
bedroom apartments include
dishwasher, carpet, full size washer &
dryer...

400 Apartments For Rent
EXCELLENT LOCATION
Near I-75
John R. Eastside between
14 & 15 Mile Rds.

Bloomfield Hills
ONE HALF ACRE
FULLY IMPROVED LOTS
Priced from \$39,950
647-0760 - 644-4024

W. Bloomfield Twp.
FULLY improved, unique custom
buildings sites now available in
Chandross Villas subdivision...

ORTONVILLE AREA
COUNTRY HOMES
THE HUSH OF COUNTRY LIVING and
the convenience of living within 20
miles of Flint or Pontiac...

Wonderful Investment Property
Approximately 115 acres. Backing to
Twelve Oaks area in Novi. Will sell
subject to rezoning...

Castelli
NO BRAG - JUST FACT
I pay the highest dollar for
homes and will prove it. Call me
last.

BIRMINGHAM AREA
1 Bedroom
\$395 per month
With heat
644-4024

BIRMINGHAM AREA
2 & 3 bedroom luxury Apts
\$440-\$810
647-1508

PLYMOUTH HOUSE
APTS.
Central downtown area
Beautiful 1 & 2 bedroom
apts. For \$285. No pets.

East Pointe Townhouses
1 1/2 Mile-Groesbeck
1-2-3 Bedroom Apts
RENT INCLUDES
Stove
Refrigerator
Heat
Hot Water
Carpeting
Private Entrance
Laundry Facilities
Playground

CRANBROOK
ASSOC. INC. REALTORS
645-5790
CAREFUL HOMEBUILDING
Our plan or yours. Our lot or yours. You
can do part F.L. Roberts Building Co
453-4129

340 Lake-River-Resort
Property For Sale
HARBOR SPRINGS, Little Traverse Twp.
4 bedroom condo 2 1/2 baths, with
fireplace, pool, paved road, 2x30
dock, boat house...

Barry Young & Co.
REAL ESTATE
252 M.E. Ortonville, Mich
1-627-2738
Think Young

360 Business Opportunities
A GREAT tax shelter business. Shaker is
a unique business opportunity. Open
meeting to those wishing to be sponsored
investors...

400 Apartments For Rent
We do not want to list your home. We
want to buy it. No fees or commissions.
Just the best price.

BIRMINGHAM AREA
1 Bedroom
\$395 per month
With heat
644-4024

BRIGHTON
THE GLENS AT HAMILTON FARMS
Sited in a quiet, wooded area. Rentals
begin at \$275. Flint Rd off Grand Blvd.

CHATHAM HILLS
APT. HOME
WITH ATTACHED GARAGE
IN FARMINGTON
ON OLD GRAND RIVER

RENT INCLUDES
Stove
Refrigerator
Heat
Hot Water
Carpeting
Private Entrance
Laundry Facilities
Playground

CRANBROOK
ASSOC. INC. REALTORS
645-5790
CAREFUL HOMEBUILDING
Our plan or yours. Our lot or yours. You
can do part F.L. Roberts Building Co
453-4129

342 Lakofront Property
A BEAUTIFUL LAKEFRONT VIEW
2 bedroom brick ranch. Large living
room, fireplace, carpeted, deck,
basement, 2 car garage, new gas furnace...

Barry Young & Co.
REAL ESTATE
252 M.E. Ortonville, Mich
1-627-2738
Think Young

360 Business Opportunities
A GREAT tax shelter business. Shaker is
a unique business opportunity. Open
meeting to those wishing to be sponsored
investors...

Castelli
NO BRAG - JUST FACT
I pay the highest dollar for
homes and will prove it. Call me
last.

BIRMINGHAM AREA
1 Bedroom
\$395 per month
With heat
644-4024

BRIGHTON
THE GLENS AT HAMILTON FARMS
Sited in a quiet, wooded area. Rentals
begin at \$275. Flint Rd off Grand Blvd.

CHATHAM HILLS
APT. HOME
WITH ATTACHED GARAGE
IN FARMINGTON
ON OLD GRAND RIVER

RENT INCLUDES
Stove
Refrigerator
Heat
Hot Water
Carpeting
Private Entrance
Laundry Facilities
Playground

CRANBROOK
ASSOC. INC. REALTORS
645-5790
CAREFUL HOMEBUILDING
Our plan or yours. Our lot or yours. You
can do part F.L. Roberts Building Co
453-4129

342 Lakofront Property
A BEAUTIFUL LAKEFRONT VIEW
2 bedroom brick ranch. Large living
room, fireplace, carpeted, deck,
basement, 2 car garage, new gas furnace...

Barry Young & Co.
REAL ESTATE
252 M.E. Ortonville, Mich
1-627-2738
Think Young

360 Business Opportunities
A GREAT tax shelter business. Shaker is
a unique business opportunity. Open
meeting to those wishing to be sponsored
investors...

Castelli
NO BRAG - JUST FACT
I pay the highest dollar for
homes and will prove it. Call me
last.

BIRMINGHAM AREA
1 Bedroom
\$395 per month
With heat
644-4024

BRIGHTON
THE GLENS AT HAMILTON FARMS
Sited in a quiet, wooded area. Rentals
begin at \$275. Flint Rd off Grand Blvd.

CHATHAM HILLS
APT. HOME
WITH ATTACHED GARAGE
IN FARMINGTON
ON OLD GRAND RIVER

RENT INCLUDES
Stove
Refrigerator
Heat
Hot Water
Carpeting
Private Entrance
Laundry Facilities
Playground

CRANBROOK
ASSOC. INC. REALTORS
645-5790
CAREFUL HOMEBUILDING
Our plan or yours. Our lot or yours. You
can do part F.L. Roberts Building Co
453-4129

342 Lakofront Property
A BEAUTIFUL LAKEFRONT VIEW
2 bedroom brick ranch. Large living
room, fireplace, carpeted, deck,
basement, 2 car garage, new gas furnace...

Barry Young & Co.
REAL ESTATE
252 M.E. Ortonville, Mich
1-627-2738
Think Young

360 Business Opportunities
A GREAT tax shelter business. Shaker is
a unique business opportunity. Open
meeting to those wishing to be sponsored
investors...

Castelli
NO BRAG - JUST FACT
I pay the highest dollar for
homes and will prove it. Call me
last.

BIRMINGHAM AREA
1 Bedroom
\$395 per month
With heat
644-4024

BRIGHTON
THE GLENS AT HAMILTON FARMS
Sited in a quiet, wooded area. Rentals
begin at \$275. Flint Rd off Grand Blvd.

CHATHAM HILLS
APT. HOME
WITH ATTACHED GARAGE
IN FARMINGTON
ON OLD GRAND RIVER

RENT INCLUDES
Stove
Refrigerator
Heat
Hot Water
Carpeting
Private Entrance
Laundry Facilities
Playground

CRANBROOK
ASSOC. INC. REALTORS
645-5790
CAREFUL HOMEBUILDING
Our plan or yours. Our lot or yours. You
can do part F.L. Roberts Building Co
453-4129

342 Lakofront Property
A BEAUTIFUL LAKEFRONT VIEW
2 bedroom brick ranch. Large living
room, fireplace, carpeted, deck,
basement, 2 car garage, new gas furnace...

Barry Young & Co.
REAL ESTATE
252 M.E. Ortonville, Mich
1-627-2738
Think Young

360 Business Opportunities
A GREAT tax shelter business. Shaker is
a unique business opportunity. Open
meeting to those wishing to be sponsored
investors...

Castelli
NO BRAG - JUST FACT
I pay the highest dollar for
homes and will prove it. Call me
last.

BIRMINGHAM AREA
1 Bedroom
\$395 per month
With heat
644-4024

BRIGHTON
THE GLENS AT HAMILTON FARMS
Sited in a quiet, wooded area. Rentals
begin at \$275. Flint Rd off Grand Blvd.

CHATHAM HILLS
APT. HOME
WITH ATTACHED GARAGE
IN FARMINGTON
ON OLD GRAND RIVER

RENT INCLUDES
Stove
Refrigerator
Heat
Hot Water
Carpeting
Private Entrance
Laundry Facilities
Playground

CRANBROOK
ASSOC. INC. REALTORS
645-5790
CAREFUL HOMEBUILDING
Our plan or yours. Our lot or yours. You
can do part F.L. Roberts Building Co
453-4129

342 Lakofront Property
A BEAUTIFUL LAKEFRONT VIEW
2 bedroom brick ranch. Large living
room, fireplace, carpeted, deck,
basement, 2 car garage, new gas furnace...

Barry Young & Co.
REAL ESTATE
252 M.E. Ortonville, Mich
1-627-2738
Think Young

360 Business Opportunities
A GREAT tax shelter business. Shaker is
a unique business opportunity. Open
meeting to those wishing to be sponsored
investors...

Castelli
NO BRAG - JUST FACT
I pay the highest dollar for
homes and will prove it. Call me
last.

BIRMINGHAM AREA
1 Bedroom
\$395 per month
With heat
644-4024

BRIGHTON
THE GLENS AT HAMILTON FARMS
Sited in a quiet, wooded area. Rentals
begin at \$275. Flint Rd off Grand Blvd.

CHATHAM HILLS
APT. HOME
WITH ATTACHED GARAGE
IN FARMINGTON
ON OLD GRAND RIVER

RENT INCLUDES
Stove
Refrigerator
Heat
Hot Water
Carpeting
Private Entrance
Laundry Facilities
Playground

CRANBROOK
ASSOC. INC. REALTORS
645-5790
CAREFUL HOMEBUILDING
Our plan or yours. Our lot or yours. You
can do part F.L. Roberts Building Co
453-4129

342 Lakofront Property
A BEAUTIFUL LAKEFRONT VIEW
2 bedroom brick ranch. Large living
room, fireplace, carpeted, deck,
basement, 2 car garage, new gas furnace...

Barry Young & Co.
REAL ESTATE
252 M.E. Ortonville, Mich
1-627-2738
Think Young

360 Business Opportunities
A GREAT tax shelter business. Shaker is
a unique business opportunity. Open
meeting to those wishing to be sponsored
investors...

Castelli
NO BRAG - JUST FACT
I pay the highest dollar for
homes and will prove it. Call me
last.

BIRMINGHAM AREA
1 Bedroom
\$395 per month
With heat
644-4024

BRIGHTON
THE GLENS AT HAMILTON FARMS
Sited in a quiet, wooded area. Rentals
begin at \$275. Flint Rd off Grand Blvd.

CHATHAM HILLS
APT. HOME
WITH ATTACHED GARAGE
IN FARMINGTON
ON OLD GRAND RIVER

RENT INCLUDES
Stove
Refrigerator
Heat
Hot Water
Carpeting
Private Entrance
Laundry Facilities
Playground

CRANBROOK
ASSOC. INC. REALTORS
645-5790
CAREFUL HOMEBUILDING
Our plan or yours. Our lot or yours. You
can do part F.L. Roberts Building Co
453-4129

342 Lakofront Property
A BEAUTIFUL LAKEFRONT VIEW
2 bedroom brick ranch. Large living
room, fireplace, carpeted, deck,
basement, 2 car garage, new gas furnace...

Barry Young & Co.
REAL ESTATE
252 M.E. Ortonville, Mich
1-627-2738
Think Young

360 Business Opportunities
A GREAT tax shelter business. Shaker is
a unique business opportunity. Open
meeting to those wishing to be sponsored
investors...

Castelli
NO BRAG - JUST FACT
I pay the highest dollar for
homes and will prove it. Call me
last.

BIRMINGHAM AREA
1 Bedroom
\$395 per month
With heat
644-4024

BRIGHTON
THE GLENS AT HAMILTON FARMS
Sited in a quiet, wooded area. Rentals
begin at \$275. Flint Rd off Grand Blvd.

CHATHAM HILLS
APT. HOME
WITH ATTACHED GARAGE
IN FARMINGTON
ON OLD GRAND RIVER

RENT INCLUDES
Stove
Refrigerator
Heat
Hot Water
Carpeting
Private Entrance
Laundry Facilities
Playground

CRANBROOK
ASSOC. INC. REALTORS
645-5790
CAREFUL HOMEBUILDING
Our plan or yours. Our lot or yours. You
can do part F.L. Roberts Building Co
453-4129

342 Lakofront Property
A BEAUTIFUL LAKEFRONT VIEW
2 bedroom brick ranch. Large living
room, fireplace, carpeted, deck,
basement, 2 car garage, new gas furnace...

Barry Young & Co.
REAL ESTATE
252 M.E. Ortonville, Mich
1-627-2738
Think Young

360 Business Opportunities
A GREAT tax shelter business. Shaker is
a unique business opportunity. Open
meeting to those wishing to be sponsored
investors...

Castelli
NO BRAG - JUST FACT
I pay the highest dollar for
homes and will prove it. Call me
last.

BIRMINGHAM AREA
1 Bedroom
\$395 per month
With heat
644-4024

BRIGHTON
THE GLENS AT HAMILTON FARMS
Sited in a quiet, wooded area. Rentals
begin at \$275. Flint Rd off Grand Blvd.

CHATHAM HILLS
APT. HOME
WITH ATTACHED GARAGE
IN FARMINGTON
ON OLD GRAND RIVER

RENT INCLUDES
Stove
Refrigerator
Heat
Hot Water
Carpeting
Private Entrance
Laundry Facilities
Playground

CRANBROOK
ASSOC. INC. REALTORS
645-5790
CAREFUL HOMEBUILDING
Our plan or yours. Our lot or yours. You
can do part F.L. Roberts Building Co
453-4129

342 Lakofront Property
A BEAUTIFUL LAKEFRONT VIEW
2 bedroom brick ranch. Large living
room, fireplace, carpeted, deck,
basement, 2 car garage, new gas furnace...

Barry Young & Co.
REAL ESTATE
252 M.E. Ortonville, Mich
1-627-2738
Think Young

360 Business Opportunities
A GREAT tax shelter business. Shaker is
a unique business opportunity. Open
meeting to those wishing to be sponsored
investors...

Castelli
NO BRAG - JUST FACT
I pay the highest dollar for
homes and will prove it. Call me
last.

BIRMINGHAM AREA
1 Bedroom
\$395 per month
With heat
644-4024

BRIGHTON
THE GLENS AT HAMILTON FARMS
Sited in a quiet, wooded area. Rentals
begin at \$275. Flint Rd off Grand Blvd.

CHATHAM HILLS
APT. HOME
WITH ATTACHED GARAGE
IN FARMINGTON
ON OLD GRAND RIVER

RENT INCLUDES
Stove
Refrigerator
Heat
Hot Water
Carpeting
Private Entrance
Laundry Facilities
Playground

400 Apartments For Rent
FARMINGTON LIVONIA
Luxury apartments. Dishwasher, security intercom, soundproof, pool, clubhouse. Sorry no pets. Adult community. 1 & 2 bedrooms available.
IMMEDIATE OCCUPANCY
COME OUT & SEE US
Merriman Rd. (Orchard Lake Rd.)
Just one block S. of 8 Mile Rd.
MERRIMAN PARK APTS
The most beautiful garden apartments in Michigan

400 Apartments For Rent
Franklin Palmer
OFF PALMER RD. W. OF LILLEY
IN CANTON TWP.
Luxury 1 & 2 Bedrooms
from \$260
Central Air Conditioning
Shag Carpeting
Pool & Sauna
Sound Conditioned
Masonry Walls
Concrete Floors
MODELS OPEN DAILY 12-6pm
397-0200
FRANKLIN Village, Carriage House for single professional. For interview call 626-2323

400 Apartments For Rent
GREENFIELD LINCOLN AREA. Luxurious 3 bedroom. Air conditioned, carpeting, appliances, heat and hot water included. Dishwasher, carport, no pets. 626-4196
GROSVENOR SOUTH TOWNHOUSES
SPACIOUS 1-2-3 BEDROOMS ELM ST., TAYLOR
East of Telegraph South of Giddard
MONTHLY RENT INCLUDES:
Private Entrance
Refrigerator & Dishwasher
Gas Heat / Hot Water
Carpeting
Ranges and Oven
Park & Play Ground Area
Laundry Facilities
CHILDREN WELCOME
Office open daily 9AM-6PM
Sat. & Sun. 12 Noon-4PM
Evening appointments
Call 287-8305
Equal Housing Opportunity

400 Apartments For Rent
GARDEN CITY & LINCOLN PARK
Sharp 1 bedroom, appliances, carpet, some utilities. AAA Home Rentals - 381-9194
GARDEN CITY
3 room upper in private home, carpeting, appliances. Mature woman preferred. Call 565-7609
HIDDEN OAKS OF SOUTHFIELD
Spacious 2 bedroom apartments nestled cozily among the trees.
Prices from \$345.
\$57-4520
Managed by Burlington Management
HOVER-9 MILE AREA
Spacious 2 bedroom townhouse. \$285 monthly. Central air, no pets. MACARTHUR MANOR 755-3671
IMMEDIATE OCCUPANCY for one bedroom apartment. Air conditioned, heat & hot water furnished. Swimming pool. On 7 Mile rd. W. of Telegraph. Senior citizens welcome. 538-3684

400 Apartments For Rent
LEASES ARE necessary for our 2 bedroom luxury apartments, but we can meet your needs with 6 month, 1 year or 2 year lease. Cranbrook Centre, Southfield, between 12 & 13 Mile Rds. 642-7777
LIVE IN LUXURY
Pontrail Apts
On Pontrail Trail between 10 & 11 Mile Rds. 1 & 2 bedroom luxury apts from \$245, heat included.
NO SECURITY DEPOSIT if qualified
437-3303
LIVE ON THE PARK
PLYMOUTH PARK APARTMENTS
One or two bedroom carpeted living room and hall. Central air conditioning, kitchen built-ins, basement, parking, pool. Ready for occupancy \$285 and \$288 no heat included. See Manager 40225 Plymouth Rd., Plymouth Twp.
LOVELY WESTLAND WOODS - Attractive 1 bedroom apartment, \$285 monthly. Spacious 2 bedroom apartment \$320 monthly. Decorated, carpeted & heat included.
728-2880
LUXURY APTS AVAILABLE
1 bedroom - \$465 per month
2 bedrooms - \$605 per month
1 yr lease. Please call 644-6105

400 Apartments For Rent
NOVI WATERVIEW FARMS
45685 Timberland
Pontiac Trail, E. of Beck Rd.
Min from Twelve Oaks Mall
RENT ROLL BACK
1 Bedroom from \$240
Includes Heat, Central Air
Carpeting, Pool, Clubhouse
Tennis Courts,
Sound Conditioned
624-0004
NOVI - 1 Month's Free Rent - \$147/month. 2 bedrooms, 1 1/2 baths, all appliances, basement. Days, 661-7045, or evenings, 421-7956
OAKLAND MALL APARTMENTS
ONE MONTH'S FREE RENT
Limited Offer
New Tenants Only
ONE & TWO BEDROOMS, FROM \$290 INCLUDES HEAT
Carpeting, air conditioning & swimming pool
Close to I-75 expressway and just blocks from Oakland Mall Shopping Center
365 East Edmund St., just East of John R and S. of 14 Mile Rd. in Madison Heights
PHONE 588-5558
9AM-5PM Mon. thru Fri.
10-4 Sat., 12-4 Sun.

400 Apartments For Rent
ONE and 2 bedroom apartments for rent in Northville. \$270 and \$195. Heat and water included. Washers and dryers in every building. Air conditioning. Call between 2-6PM. 348-6181
ONE BEDROOM APARTMENTS
Westland Estates
6843 N Wayne Rd. Westland
721-3600
ONE BEDROOM APT. Schoolcraft & Outer Drive Area. \$240 mo., 1 yr lease. Heat & appliances included. Call after 5 PM. 534-3446
ONE MONTH FREE RENT
Accepting applications for studio and one bedroom apartments, from \$215. Apply manager office. 23759 Fenwick 2201-B. 532-9234

400 Apartments For Rent
OAKLAND VALLEY NO. 2 APTS. LAST MONTHS RENT FREE
Near Oakland and University. N. on Squirrel, past Walton Blvd. S. of Birchwood to Patrick Henry Dr. B. to office Apt. 611. Studio/1 and 2 bedroom apartments. Spacious living room, door, wall, balconies. Self cleaning ovens, self defrosting refrigerator, dishwashers. Starting \$80 per month. Call Tues., Wed. Fri. 9:30-4:30 Thurs 9:30-5:30
373-2196
PALMER PARK
One bedroom apt., newly decorated, extra includes heat. Adult preferred. \$210 includes heat. Lease available. 861-5010
PALMER TERRACE APARTMENTS 2006 Veneto, Westland.
Quiet one & two bedroom apartments. Heat included. Adults, from \$225. 326-2770
Parkway Apartments
Beech at Shawwasee
1 block N of 8 Mile
CITY OF SOUTHFIELD
1 & 2 bedroom Apartments From \$235 INCLUDES GAS HEAT, hot water, carpeting, balcony, 2 pools, walking distance to shopping and transportation. Mon-Sat. 9-4:30 Sun. noon-4:30
357-2503

400 Apartments For Rent
PIERRE APTS from \$246 includes heat, carpeting, stove, refrigerator, smoke alarms & much more. 1925 Shiawassee, E. of Telegraph No. 7 Mile 538-0281
PLYMOUTH - Spacious 2 bedroom ranch unit. Quiet adult complex. Available April. \$345 includes heat. Security required. 591-2878 or 459-7494
PLYMOUTH Attractive 1 bedroom Carpet, appliances air condition, laundry. \$264. No pets \$270 includes heat. 995-9624 or Mrs. Geller, 453-0221
PLYMOUTH 1 bedroom lower, stove, refrigerator, heat & water. \$285 plus security. Call after 5:30PM. 455-6243
PLYMOUTH 1 bedroom, available April 1st, Plymouth Rd. and Holbrook Couples preferred. Stove, refrigerator, carpeting, draperies. \$260 plus utilities. After 3 PM. 453-8194

FOREST LANE APARTMENTS
6200 North Wayne Rd.
WESTLAND
2 bedrooms, \$289
Carpeting, appliances, swimming pool, 2 car parking. Heat included. Close to Westland Shopping Center. 728-4800
FOR LUXURY apartment living - 1,320 sq. ft., with twice the normal closet & storage space, make an appointment to see Cranbrook Centre in Southfield. 642-7777

FREE FIRST MONTH
FOR IMMEDIATE OCCUPANCY SOMERSET MALL AREA Maplewood Manor
2209 Crooks Rd.
North of Maple (15 Mile)
1 OR 2 BEDROOM
HEAT INCLUDED
Completely carpeted, all utilities except electricity. Pool, air conditioning & party room. Adults. 14 pets. Also near Oakland Mall & I-75. Open Mon - Sat, Noon till 5 PM. 362-0730
RESIDENT MGR.
GARDEN CITY, Adult complex, no pets. 1 bedroom, kitchen appliances, central heat & air. Water paid by landlord. \$235 per month. 423-3181
GARDEN CITY - brand new 1 and 2 bedroom apartments. From \$310 per month, heat & water included. 2833 Parlo. 422-5487
GARDEN CITY, large 2 bedroom, balcony Apartment. Carpeted, appliances & water paid. Adults preferred. \$285 per month. 261-4067
GRAYTON GARDENS
Beautiful newly remodeled, carpeting, appliances, Outer Dr. & Jeffries. 531-1582 557-0770

HAMPTON COURT
OFFERING \$100 OFF FIRST MONTHS RENT
IMMEDIATE OCCUPANCY ON 1 & 2 BEDROOMS
Very spacious apartments with ample storage. Swimming pool and carports available.
729-1020
Office hours Mon-Thru/Fri 9-6, Sat. 1-5
Located on Ford Road, 1 block East of Wayne Road, 5689 N. CHRISTINE WESTLAND

400 Apartments For Rent
IMPERIAL MANOR
7 Mile - Telegraph Area
1 & 2 bedrooms includes heat & water, air conditioning, carpeting, laundry & storage facilities, pool & security.
538-2158
IN PLYMOUTH, 1 bedroom, living room, dining area, kitchen with appliances. Reduced rent for lawn mowing. 453-4521
INTOWN BIRMINGHAM 1 bedroom apartment. Immediate occupancy. \$225 per month (call after 5pm. 626-8260
Lusher near Grand River 1 - 2 bedroom, carpeting, drapes, appliances. Heat included, no pets from \$245. After 5 PM. 369-1499
LAYSER 7 MILE AREA. Two bedrooms, carpeting, appliances, dishwasher, laundry room. No pets. Senior citizens preferred. 455-4953
LARGE & 2 BEDROOM APTS.
City of Rochester
From \$300 a month.
751-8536, 651-6497, 296-9534

400 Apartments For Rent
NORTHVILLE, comfortable 2 bedroom apartment with garage on second floor of older home. Stove, refrigerator, carpeting. \$315 plus electricity. \$450 security deposit, references, no pets. 1 yr lease. Please call 349-2319
NORTHVILLE, newly decorated, carpeted, stove, refrigerator, heat included. \$275 and up. Adults preferred, no pets. Security references. Call Eves. 533-3971
NORTHVILLE, 2nd level, 2 bedroom, 6 miles W. of Northville. Adults preferred, no dogs. \$270 month plus utilities. Ask for Abe. 444-8788
NORTHWOOD APARTMENTS
1127 W. Farnum
11 Mile - Woodward
1 bedroom units
Rent includes:
• Heat
• Hot Water
• Air conditioning
• Carpeting
• Disposal
• Range
• Refrigerator
• Laundry & Storage Facilities
• Parking
• Swimming Pool
541-3332
ROCHESTER PARK APTS.
From your 2 bedroom apartment or townhouse, including all the conveniences a good apartment should have. WATER (soft running), CARPET (on the floor), AIR CONDITIONING (summer & winter), HEAT (summer optional). CARPORT FOR CARS (no horses please), ICE BOX (Electric), range (oven top), DISHWASHER (For overworked husbands), OFFAL GRINDER (For Your Excess Offals) and caretakers that care. From \$330 per month. "Little Humans" welcome. Call collect, 1-651-9751 or 1-651-8090.
Furnished Apts. on Request
ROCHESTER PARK APTS.

400 Apartments For Rent
ROCHESTER PARK APTS.
FROM \$290
INCLUDES HEAT
Carpeting, air conditioning & swimming pool
Close to I-75 expressway and just blocks from Oakland Mall Shopping Center
365 East Edmund St., just East of John R and S. of 14 Mile Rd. in Madison Heights
PHONE 588-5558
9AM-5PM Mon. thru Fri.
10-4 Sat., 12-4 Sun.
OVERLOOK ROCHESTER
The GATEWAYS APTS. is one of the most prestigious established communities in FARMINGTON HILLS.
2 Bedrooms
From \$410
Carpeting included. Clubhouse with many facilities. Pool & Tennis Courts.
Entrance to THE GATEWAYS is on 12 Mile Rd. just west of Middlebelt Rd.
474-6082 474-5526
THE GATEWAYS APARTMENTS IN FARMINGTON HILLS
ONE MONTH FREE RENT
AT
Newport Creek of Farmington Hills
Enjoy the comfort and hominess of a small community with all the features and conveniences of a larger complex.
Priced from only \$330 month.
For more information, call 477-7920.
OPEN Mon. Tues. Wed. Fri. Sat. (closed Tues. & Thurs. except by appt. Managed by Burlington Management)
681-4100

400 Apartments For Rent
Plymouth Hills Apartments
768 S. Mill St.
One & Two Bedroom from \$285
*In our own washer & dryer
*Self-cleaning oven
*Automatic dishwasher
*Heats duty garbage disposal
*Fully carpeted
*Air conditioning
455-4721 278-8319
PLYMOUTH Lower flat. Super in town location. 2 bedrooms, living room, dining room, kitchen, first floor laundry room & garage. \$395 month. 348-6799
PLYMOUTH MANOR APTS.
CITY OF PLYMOUTH
Central downtown area.
Beautiful 1 & 2 bedroom
apts. from \$290. No pets.
455-3880
PLYMOUTH one bedroom apartment, very comfortable. Appliances, heat, garage included. Beautiful area. \$250 month. 455-7451
PLYMOUTH spacious 2 bedroom, heat, carpeting, appliances furnished, preferred location. No pets. Mature adults preferred. \$300 459-9507
PLYMOUTH - Spacious 2 bedroom appliances, carpet, 2nd floor, quiet adult complex. Heat included, \$315 plus security. 591-2078 or 459-7884

400 Apartments For Rent
Patrick Henry Apartments
Near Rochester & Oaklawn University
1 & 2 bedroom apartments with carpeting, air conditioning, patios, porches, swimming pool, clubhouse & sauna.
Sorry No Pets
From \$275.
2760 PATRICK HENRY DR.
Rental Office Open Daily
373-6770
PLYMOUTH DOWNTOWN Ideal location. Newly decorated efficiency. All utilities, range & refrigerator included. \$220 per month After 6PM. 427-1140
ROYAL OAK AREA - Spacious 1 bed room, carpeted. \$290 monthly. Decorated, appliances, heat & water included. Slightly higher. Mature adults preferred. Call 9am-4pm. Mon thru Sat. 547-5555
ROYAL OAK Red Run Apts. 1 bed room available starting at \$300. Golf course view available, slightly higher. Mature adults preferred. Call 9am-4pm. Mon thru Sat. 547-5555
ROYAL OAK 13 Mile Woodward area. Close to shopping. Beautiful spacious 2 bedroom apartment. \$335 month. Air conditioning, heat & carport included. 576-1378

400 Apartments For Rent
SPRING SPECIAL
GAS SAVING LUXURY (15 minutes to Downtown)
STUDIO & 1 BEDROOM APTS
FROM \$195 INCLUDING
Stove, refrigerator, hot water, new carpet, garbage disposal, air conditioning, swimming pool.
TOP OF THE DRIVE
Redford area - Outer Dr. & Schoolcraft off I-96, just E. of Telegraph.
531-2260
SR. CITIZEN APARTMENT
From \$195
Redford
531-2260
STUDIO APT
Available for rent. \$205 per month. Located Schoolcraft - Outer Dr. area. Call 531-8100
TELEGRAPH 7 Mile. one bedroom, appliances, air conditioning, carpet, gas. \$225. 879-2655 or 758-0430

400 Apartments For Rent
FREE FIRST MONTH
IMMEDIATE OCCUPANCY
OAK PARK AREA
SCOTIA MANOR
12800 W. 9 MILE RD.
Near Coolidge & Scotia
ONE OR 2 BEDROOM
HEAT INCLUDED
Completely carpeted. All utilities except electricity. Pool, air conditioning, party room. Adults, no pets. Large well lighted parking lot, near shopping centers and 9 Mile & Coolidge bus lines. SEE RESIDENT MGR.
In all of Detroit, the premier apartment address is in West Bloomfield.

400 Apartments For Rent
ON THE LAKE
1 & 2 Bedroom Apartments From \$290
Rent includes:
• HEAT
• DISHWASHER
• STOVE
• CENTRAL AIR
• REFRIGERATOR
• CLUBHOUSE & POOL
• CONVENIENT TO TWELVE OAKS SHOPPING MALL
BEACHWALK APARTMENTS
On 14 Mile, between Haggerty & Novi Rd.
Call for information
624-4434

400 Apartments For Rent
FAIRMONT PARK
... because it was the only \$500 apartment I could find... for \$350 a month!

400 Apartments For Rent
WALDENWOOD
Extraordinarily spacious 1 & 2 bedroom Apartments. 2 & 3 bedroom Townhouses featuring separate breakfast rooms, family rooms, and 1 1/2 baths on a uniquely wooded site.
FROM \$410 INCLUDING
• HEAT AND COVERED PARKING
• CENTRAL AIR
• POOL AND CLUB HOUSE
• BALCONIES
• ENORMOUS STORAGE AREA
"A REPUTATION FOR METICULOUS MAINTENANCE"
On West 10 Mile Rd., 1 block E. of Telegraph
353-1372
Mon.-Fri., 9-5 p.m.

400 Apartments For Rent
Glen Cove
Now renting 1 & 2 bedroom spacious apartments from \$260. Includes heat and appliances. Special Rates for Senior Citizens.
Immediate Occupancy
On Telegraph between Plymouth and Schoolcraft
538-2497

400 Apartments For Rent
CASS LAKE SHORE CLUB
Corner of Cass Lake Road & Cass Elizabeth Lake Road
Near Orchard Lake Road M-59 Telegraph
SAIL UP TO YOUR DOOR
MICHIGAN'S LARGEST INLAND LAKE
• 1 & 2 Bedrooms
• Pool-Beach-Tennis
• Clubhouse
• Dishwashers
• Small Pets Allowed
FROM \$275
HEAT & COVERED PARKING INCLUDED
Model Open 8-6 Daily, 12-6 Weekends
Furnished & Unfurnished Apartments Available
681-4100

400 Apartments For Rent
Northgate Apts.
RENT INCLUDES
• Air-Conditioning • Range • Refrigerator • Carpeting
• Garbage Disposal • Laundry & Storage Facilities
• Swimming Pool • Tennis Courts • Activity Building
• Heat & Hot Water • Movies and Entertainment
FROM \$250
GREENFIELD AT 10 1/2 MILE RD.
Call
OFFICE OPEN DAILY SAT. & SUN 968-8688

400 Apartments For Rent
APARTMENTS
Furnished - Unfurnished
Take the hassle out of your hunt! Save time and gas.
... because, with parking, I don't have to scrape my windshield every morning...
9 Mile & Drake Roads, FARMINGTON HILLS 474-2510

400 Apartments For Rent
THE VILLAGE APARTMENTS
GARDEN CITY & WESTLAND AREA SPECIAL RATE
One bedroom, \$250
Two bedroom, \$295
Includes carpeting, drapes, air conditioning, stove, refrigerator, gas heat and water. No pets.
9 AM - 5 PM Weekdays only
425-0930
THREE bedroom carpeted townhouse located minutes from downtown Birmingham. Available mid April. Call 569-1908 or 649-3524

Aldingbrooke Apartments West Bloomfield
On Drake Road, between Maple and Walnut Lake Roads. Models open everyday, 11-6. Phone: (313) 661-0770.

Swan Harbour
LUXURY LIVING ON A PRIVATE LAKE
1 & 2 Bedroom Units From \$345.00
• Sailing
• Tennis
• Pool & Community Building
• Security Intercom System
• Frost-Free Refrigerator
• Self-Cleaning Oven
• Dishwasher
• Private Patio or Balcony
• Carport
NORTHVILLE TOWNSHIP
Models open 12 to 6 daily except Wednesday Saturday & Sunday 1 to 5
CALL 348-7677

NOW RENTING
ONE and TWO Bedroom Apartments
From \$365
FINE Ridge
North side of 10 Mile Road, West of Telegraph, adjacent to TEL-EX Shopping Center.
Open: Mon. thru Fri. 9 to 4 Sat. 12 to 5
Res. Mgr. 354-3930 Office: 626-5598

NOW RENTING... Maple Tee
One & Two Bedroom Apartments and Townhouses \$375
Located on Franklin Road, just south of Northwestern Highway.

NOW RENTING... Cab Ridge
ONE and TWO BEDROOM APARTMENTS from \$365
Located on Berg Rd. N. of Civic Center Dr., E. of Telegraph Rd.
Res. Mgr. 358-1885 Office: 626-5598
Open: Mon. thru Fri. 9 to 4 Sat. 10 to 5

FAIRMONT PARK
... because it was the only \$500 apartment I could find... for \$350 a month!

Woodcrest Villa
apartments & athletic club
*Spacious 1 & 2 Bedroom Apartments
*Fireplace
*Private Athletic Club
*Firehouse Lounge & Game Room
*Indoor/Outdoor Pool
*Sauna, Whirlpool
*Platform Tennis
FURNISHED & UNFURNISHED
RENTAL INFORMATION 10 a.m. - 6 p.m. DAILY

NO RENT UNTIL APRIL 15, 1981
NORTH HILLS VILLAGE APARTMENTS
A Luxurious Apartment Community in the Northville/Novi Area
Ideal Setting... In a residential area so quiet, so private, so secluded yet so conveniently located near everything you need and everywhere you want to go. Just minutes from downtown Northville or Twelve Oaks.
Leviah See-Thru Units... 1 or 2 bedrooms, 1 or 2 baths, Hotpoint appliances, air conditioning, sliding door walls and large closets, separate storage area plus laundry room.
Special features... thru unit design with private balcony or patio, including tennis courts, swimming pool, community building and scenic pond.
Special Offer for Limited Time Only:
Over 900 sq. ft. ONE-BEDROOM APTS. from \$340 with one bath
Over 1,200 sq. ft. TWO-BEDROOM APTS. from \$395 with two baths
includes free carport
Furnished Apartments Available as well as Handicap Units
Models Open Daily 12 to 8 Phone 348-3060

THE LAURELS ON LONE PINE
FREE INSTALLATION
Offers you the convenience of apartment living in a residential setting. Natural beauty and quality accommodations set THE LAURELS ON LONE PINE apart from the average or ordinary
• 2 Bedrooms with Walk-in Closets
• 2 Full Baths
• Laundry and storage in each apartment
• Individual heating cooling in each apartment
• Interior Security Systems
• Beautiful Landscaping
• Attached enclosed garages
• Swimming Pool
• Quality Appliances
• Spacious patio
NOW RENTING FROM \$425
626-6715

WALDENWOOD
Extraordinarily spacious 1 & 2 bedroom Apartments. 2 & 3 bedroom Townhouses featuring separate breakfast rooms, family rooms, and 1 1/2 baths on a uniquely wooded site.
FROM \$410 INCLUDING
• HEAT AND COVERED PARKING • CENTRAL AIR
• POOL AND CLUB HOUSE • BALCONIES
• ENORMOUS STORAGE AREA
"A REPUTATION FOR METICULOUS MAINTENANCE"
On West 10 Mile Rd., 1 block E. of Telegraph
353-1372
Mon.-Fri., 9-5 p.m.

Glen Cove
Now renting 1 & 2 bedroom spacious apartments from \$260. Includes heat and appliances. Special Rates for Senior Citizens.
Immediate Occupancy
On Telegraph between Plymouth and Schoolcraft
538-2497

THE LAURELS ON LONE PINE
FREE INSTALLATION
Offers you the convenience of apartment living in a residential setting. Natural beauty and quality accommodations set THE LAURELS ON LONE PINE apart from the average or ordinary
• 2 Bedrooms with Walk-in Closets
• 2 Full Baths
• Laundry and storage in each apartment
• Individual heating cooling in each apartment
• Interior Security Systems
• Beautiful Landscaping
• Attached enclosed garages
• Swimming Pool
• Quality Appliances
• Spacious patio
NOW RENTING FROM \$425
626-6715

green hill
A unique new apartment park concept in Farmington Hills
OVER 70 ACRES OR PRIVATE PARKS, SPRING FED STREAMS & PONDS, BIKE, JOGGING & NATURE TRAILS, TENNIS COURTS, SWIMMING POOL, HUGE STORAGE AREAS.
1 and 2 bedroom luxury apartments (On 9 Mile Rd. 1/4 mile West of Farmington Rd.)
Furnished models. Open daily 10 a.m. - 6 p.m.
Phone 478-4664
John F. Uzris
builder/developer

Northgate Apts.
RENT INCLUDES
• Air-Conditioning • Range • Refrigerator • Carpeting
• Garbage Disposal • Laundry & Storage Facilities
• Swimming Pool • Tennis Courts • Activity Building
• Heat & Hot Water • Movies and Entertainment
FROM \$250
GREENFIELD AT 10 1/2 MILE RD.
Call
OFFICE OPEN DAILY SAT. & SUN 968-8688

APARTMENTS
Furnished - Unfurnished
Take the hassle out of your hunt! Save time and gas.
... because, with parking, I don't have to scrape my windshield every morning...
9 Mile & Drake Roads, FARMINGTON HILLS 474-2510

FAIRMONT PARK
... because, with parking, I don't have to scrape my windshield every morning...
9 Mile & Drake Roads, FARMINGTON HILLS 474-2510

TIMBERLEA VILLAGE APARTMENTS
Now leasing attractive and well-maintained 1 & 2 bedroom apartments
Prime location. Rochester area, close to shopping & minutes from Free way.
418 TIMBERLEA DR. ROCHESTER
652-3920
Office hours 9AM-5:30PM. Sat. 10AM-2PM
Accepting applications for studio and one bedroom apartments from \$215. Apply manager office. 18615 Telegraph rd apt 207. 255-1829

green hill
A unique new apartment park concept in Farmington Hills
OVER 70 ACRES OR PRIVATE PARKS, SPRING FED STREAMS & PONDS, BIKE, JOGGING & NATURE TRAILS, TENNIS COURTS, SWIMMING POOL, HUGE STORAGE AREAS.
1 and 2 bedroom luxury apartments (On 9 Mile Rd. 1/4 mile West of Farmington Rd.)
Furnished models. Open daily 10 a.m. - 6 p.m.
Phone 478-4664
John F. Uzris
builder/developer

THE VILLAGE APARTMENTS
GARDEN CITY & WESTLAND AREA SPECIAL RATE
One bedroom, \$250
Two bedroom, \$295
Includes carpeting, drapes, air conditioning, stove, refrigerator, gas heat and water. No pets.
9 AM - 5 PM Weekdays only
425-0930
THREE bedroom carpeted townhouse located minutes from downtown Birmingham. Available mid April. Call 569-1908 or 649-3524

THREE OAKS
Three newest luxury apartment community 1 & 2 bedroom apartments. All appliances carports, community building, pool, tennis courts & rural setting 1/2 mile E. of Crooks on Warrens at I-75
OPEN Mon thru Fri 10 to 6 Sat - 10 to 4 Phone 362-0088

TIMBERLEA VILLAGE APARTMENTS
Now leasing attractive and well-maintained 1 & 2 bedroom apartments
Prime location. Rochester area, close to shopping & minutes from Free way.
418 TIMBERLEA DR. ROCHESTER
652-3920
Office hours 9AM-5:30PM. Sat. 10AM-2PM
Accepting applications for studio and one bedroom apartments from \$215. Apply manager office. 18615 Telegraph rd apt 207. 255-1829

TWYCKINGHAM VALLEY
2227 W. 12 MILE
SOUTHFIELD
ONE BEDROOM APARTMENT
RENT INCLUDES
HEAT & HOT WATER
STORAGE & LAUNDRY FACILITIES EACH FLOOR
FULLY EQUIPPED KITCHEN
CARPETING
CENTRAL AIR 357-5809
UNION LAKE area, townhouse, 2 bedrooms, 1 1/2 baths, fireplace, patio, gas bar-b-cue, balcony, pool, appliances including washer and dryer. Mature adults. No pets. \$335 Mo. plus utilities, security deposit. After 6 PM. 477-1769

VILLAGE GREEN OF PLYMOUTH
Studio & 1 bedroom apartments for mature adults.
FROM \$234
Ask for Linda 769-1313

400 Apartments For Rent
Village Green
OF
BELLEVILLE
1 & 2 Bedrooms
FROM \$285
 An All Adult Community
 Heat Included
699-2040
 Weekdays 9 to 5, Sat. 9 to 12
 Village Green Management Co.

VILLAGE of Clarkston, 1 bedroom
 newly decorated, \$275 plus security.
 453-9444

VILLAGE SQUIRE
 ON Ford Rd.
 Just E. of I-275
1 & 2 BEDROOMS
FROM \$270
 Includes Heat - Fully Carpeted
 Sound Conditioned - Pool & Sauna
453-8773

WALLED LAKE 1 & 2 bedrooms on
 private lake with balconies, central air,
 heat included, recreation room, ex-
 tensive court, private beach. For in-
 formation call 624-5999

Walton Square
ONE MONTH FREE RENT
 Pontiac near I-75, Oakland University,
 Silverdome & Arrowhead Golf Course.
373-1400

WAYNE APARTMENTS
 33402 Michigan Ave. One bedroom, ap-
 pliances, parking \$225. Mature adults
 No pets. 595-8010

WAYNE 2 bedroom apt. Carpeted, air
 conditioned, swimming pool. \$240
 month includes all utilities except elect-
 ricity. Adults preferred. No pets. Call
 noon to 8pm. 728-8899

WESTLAND AREA
 1 and 2 bedroom apartments, patio or
 balcony. Appliances, carpeting, air con-
 ditioning, heat and water included.
 Close to shopping, restaurants, church-
 es & busline. Pools and tennis courts.
 6 month lease available. 326-8270

WESTLAND AREA - There are no free-
 bies. You will pay now or later. We offer
 quality housing at a fair, fixed rate. One
 bedroom apartments, \$270. Two bed-
 room apartments, \$295.
 Country Court Apartments 721-0590

WESTLAND AREA
 Spacious 1 bedroom apartment, \$270
 monthly. Attractive 2 bedroom apart-
 ment, \$295. Carpeted, decorated & in a
 lovely area. Heat included. 326-8270

WESTLAND - There are no free-
 bies. You will pay now or later. We offer
 quality housing at a fair, fixed rate. One
 bedroom apartments, \$270. Two bed-
 room apartments, \$295.
 Country Court Apartments 721-0590

Country Court
 Apartments
721-0500

WESTLAND
 Hampton Court Apartments offering
 \$100 off first months rent on 1 and 2
 bedroom apartments. Call 729-4020

WESTLAND. Lovely one bedroom.
 Drapes, heat, carpet, air, appliances,
 balcony, low move in cost \$250. See to
 appreciate. 326-4893 591-0165

WESTLAND
 Only \$235. Small efficiency, 1 bed-
 room, shower, carpeting, heat included.
 No pets. Agent 478-7640

400 Apartments For Rent

400 Apartments For Rent
 WESTLAND-Scottdale Apt. sublease, 2
 bedrooms, 1 1/2 baths. No pets. \$355 mo
 plus security deposit. Available April 1,
 1981. After 4:30. 483-3943

WESTLAND - NEAR HUDSON'S
 Large 1 bedroom. Beautifully equip'd build-
 ing. Carpets, drapes, air, etc. \$270. per
 month. 728-8176 or 549-3634

WESTLAND - 1 bedroom apartment.
 Immediate occupancy \$180 plus security
 deposit. 728-1449

WESTLAND. 1 bedroom, new carpet-
 ing, curtains, appliances, heat, private
 entrance, nice yard. References & se-
 curity. Single or couple. 721-1649

WESTLAND - 2 bedroom, stove, refrig-
 erator, heat, water included, \$390 mo.
 1 child welcome, security deposit. 453-9444

WILLOW PARK Apartments Spacious
 1-bedroom apartments available in
 Southfield luxury mid-rise. Each main-
 tenance-free apartment has fully
 equipped kitchen with pantry and eat-
 ing space, drapes, carpet, balcony, in-
 dividual storage area within apartment
 and laundry facility on each floor. Pri-
 vate park facilities include pool and
 tennis courts. Rent from \$347. Call
 556-8778

WOODWARD HGTS.
ROYAL OAK
 3388 Coolidge, near Woodward
2 BEDROOM TOWNHOUSES
 • Excellent small family units
 • Carpeting
 • Full basement storage area
 • Excellent neighborhood
COME OUT AND SEE
288-5815

8 1/2 MILE-LAHSER
 Beautiful 1 bedroom apart-
 ment in a country setting.
 Carpet, drapes, appliances,
 air. Mature adults, no pets.
 \$300.
 21200 LAHSER RD
MANAGERS APT 101.
402 Furnished Apts.
For Rent
 A CLEAN & comfortable furnished
 Berkeley efficiency, on Coolidge, 58'
 of 12 Mile Rd., carpeted, appliances, air,
 disposal. Lease & security. \$265 in-
 cludes heat. 398-4245 or 398-8253

ATTRACTIVE FURNISHED studio
 apartment in Walled Lake/West
 Bloomfield area. Pool, utilities, air.
 \$270. 644-1183 or 689-4049

BIRMINGHAM AREA
 Fully furnished 3 bedroom, 1 1/2 baths,
 finished rec room, air, available for
 Short or Long Term Lease. Walking dis-
 tance to town, close to main arteries of
 transportation \$950 per month.

Century 21
 PIETY HILL, INC. 642-8100

BIRMINGHAM East Maple, deluxe 1
 bedroom, executive apartment, in-
 cludes linens, dishes, heat, water ex-
 tra. Short term available. 646-9530

MONTHLY LEASES
 REASONABLE RATES
 Beautiful full size apartments. Com-
 pletely furnished in excellent locations.
ROYAL CHAMBERS
 855-4585

400 Apartments For Rent

402 Furnished Apts.
For Rent
Birmingham-Troy Area
 Luxury Executive Apts.
 COMPLETELY FURNISHED
 TO EVERY DETAIL.
 Maid Service Available
 Long and Short Term Leases
From \$375
280-1820

BLOOMFIELD HILLS luxury condo, 2
 bedrooms, plus den, 2 full baths, plus
 large basement. Convenient location.
 \$750 per month. 644-0107

BLOOMFIELD LAKES APARTMENTS
STUDIO APARTMENT - \$395
1 BEDROOM APARTMENT - \$390
2 BEDROOM APARTMENT - \$420

3 apartments available end of March in
 a small private adult complex. (In 2
 bedroom apt., 1 bedroom could be used
 for office or den). Includes deep shag
 carpeting, drapes, decorating furniture
 by Globe Interior, dishes, linens, silver,
 television and radio. Heat and water in-
 cluded. Washer and dryer available.
 Beach privileges on Cass Lake.

IDEAL for executives, singles or business
 persons moving into area. Short term
 lease or longer available to qualified
 applicants.

2920 SCHROEDER BLVD.
 2 blocks North of Orchard Lake Road
 off Cass Lake Road.
FOR APPOINTMENT CALL
 682-7495 681-9161

FURNISHED EXECUTIVE APTS & CONDOS
 1 bedroom \$375-\$450
 2 bedroom \$475-\$550
 3 bedroom \$575-\$650
 New furniture, large selection, ware-
 house showroom. Short or long term
 lease.

GLOBE INTERIOR RENTALS
 EAST 1100 E. Maple (1/2 mile) Troy
 W of I-75, E of Rochester Rd. 568-1800
 WEST 3743 Grand River, Farmington Hills
 at Halstead 474-3400

NEW STUDIO APARTMENTS
 Deluxe apartments, air laundry and
 storage facilities, off street parking.
 Downtown Royal Oak Adults pre-
 ferred. No pets. Applicants must make
 \$12,000 or more per year to apply.
 Call Mike 549-8320

400 Apartments For Rent

402 Furnished Apts.
For Rent
PUTNEY MEWS
 Completely Furnished Townhouses
 Monthly Lease
 ALL IN BIRMINGHAM
 19 delinquent 2 bedroom units. Dishes,
 TV, linens, utilities included. Dues
 \$750. 644-0832

SOUTHFIELD. Furnished studio apart-
 ment. Middle-aged gentleman pre-
 ferred. \$160 monthly. First, last & se-
 curity deposit. References. 576-7755

SPECIAL WEEKLY RATES
 Motel Rooms & Efficiency Apartments
 480 Single - \$75 Double
 - 17729 Telegraph Rd.
 - (1 1/2 MI. S. of Grand River)
 Mayflower Motel KE 1-8858

WAYNE - One bedroom furnished
 apartment. \$320 month includes all
 utilities \$104 security deposit. Adults
 preferred. No pets 1pm - 8pm Call
 526-8474 or 728-9669

404 Houses For Rent

ABANDON YOUR HUNT
 Select Rentals
 We Help Landlords & Tenants
 Share Listings 642-1620

ADORABLE DOLL house. North Royal
 Oak. 3 bedroom ranch. All appliances,
 garage, near Woodward, gas heat. Se-
 curity and references. \$400 - 576-1893
 \$575 a month. Phone before 5pm.
 963-4838 after 5pm & weekends 835-5818

BIRMINGHAM 1327 Cole, 2 1/2 bed-
 rooms, 1 story, basement, appliances,
 carpeted, fenced yard, \$425 per Mo
 288-5220 or 646-8330

BIRMINGHAM 1999 Haynes
 Clean 2 bedroom ranch, carpeting, ap-
 pliances, fenced yard, gas heat, near
 commuter \$375 plus security \$45 1232

BIRMINGHAM 2 bedroom, appliances,
 washer, dryer, carpeting, air condition-
 er, basement, garage, fenced, clean.
 \$400 month Security Evgs 641-7472

BIRMINGHAM 2 bedroom, all appli-
 cations, 1 1/2 car garage, newly decorated,
 near V. \$375 per month plus security
 \$395 per month. 681-0816

404 Houses For Rent
 BIRMINGHAM AREA, executive white
 brick 3 bedroom colonial. Swimming
 pool, family dining, living room fire-
 place, finished basement, 2 1/2 baths,
 overlooking Birmingham Country Club
 \$695 a month. Immediate occupancy.
 Preferably 1-2 year lease. 642-8180

BIRMINGHAM - 3 bedroom brick
 ranch. Fireplace, carpeting, kitchen ap-
 pliances, basement, garage. Available
 now at \$400 firm. 647-0761

BLOOMFIELD HILLS - Mulberry
 Square 2 bedroom, 2 bath 2nd-floor
 condominium. Kitchen appliances, car-
 peting, drapes, carpet. Adults, no pets.
 Available now at \$550.

BIRMINGHAM - 3 bedroom brick
 ranch, screened & glassed porch, 2 car
 garage, kitchen appliances, carpeting
 drapes. Available now at \$575.

STEELE HTS. - 4 bedroom, 2 1/2 bath
 colonial. Family room with fireplace,
 carpeting, drapes, all appliances, at-
 tached garage. Available now at \$609.

BIRMINGHAM - in town, rent, 3
 bedrooms, short term, long term avail-
 able, immediate occupancy 646-2826

BIRMINGHAM & OAK PARK AREAS
 Beautiful 2 and 3 bedroom homes. Car-
 peting & appliances. Near expressways,
 2 1/2 car garage with openers. Available
 April 1 at \$650.

BIRMINGHAM 1327 Cole, 2 1/2 bed-
 rooms, 1 story, basement, appliances,
 carpeted, fenced yard, \$425 per Mo
 288-5220 or 646-8330

BIRMINGHAM 1999 Haynes
 Clean 2 bedroom ranch, carpeting, ap-
 pliances, fenced yard, gas heat, near
 commuter \$375 plus security \$45 1232

BIRMINGHAM 2 bedroom, appliances,
 washer, dryer, carpeting, air condition-
 er, basement, garage, fenced, clean.
 \$400 month Security Evgs 641-7472

BIRMINGHAM 2 bedroom, all appli-
 cations, 1 1/2 car garage, newly decorated,
 near V. \$375 per month plus security
 \$395 per month. 681-0816

404 Houses For Rent
 BIRMINGHAM - 3 bedroom brick
 ranch, fireplace, carpeting, kitchen ap-
 pliances, basement, garage. Available
 now at \$400 firm. 647-0761

BLOOMFIELD HILLS - Mulberry
 Square 2 bedroom, 2 bath 2nd-floor
 condominium. Kitchen appliances, car-
 peting, drapes, carpet. Adults, no pets.
 Available now at \$550.

BIRMINGHAM - 3 bedroom brick
 ranch, screened & glassed porch, 2 car
 garage, kitchen appliances, carpeting
 drapes. Available now at \$575.

STEELE HTS. - 4 bedroom, 2 1/2 bath
 colonial. Family room with fireplace,
 carpeting, drapes, all appliances, at-
 tached garage. Available now at \$609.

BIRMINGHAM - in town, rent, 3
 bedrooms, short term, long term avail-
 able, immediate occupancy 646-2826

BIRMINGHAM & OAK PARK AREAS
 Beautiful 2 and 3 bedroom homes. Car-
 peting & appliances. Near expressways,
 2 1/2 car garage with openers. Available
 April 1 at \$650.

BIRMINGHAM 1327 Cole, 2 1/2 bed-
 rooms, 1 story, basement, appliances,
 carpeted, fenced yard, \$425 per Mo
 288-5220 or 646-8330

BIRMINGHAM 1999 Haynes
 Clean 2 bedroom ranch, carpeting, ap-
 pliances, fenced yard, gas heat, near
 commuter \$375 plus security \$45 1232

BIRMINGHAM 2 bedroom, appliances,
 washer, dryer, carpeting, air condition-
 er, basement, garage, fenced, clean.
 \$400 month Security Evgs 641-7472

BIRMINGHAM 2 bedroom, all appli-
 cations, 1 1/2 car garage, newly decorated,
 near V. \$375 per month plus security
 \$395 per month. 681-0816

404 Houses For Rent
 BIRMINGHAM - 3 bedroom brick
 ranch, fireplace, carpeting, kitchen ap-
 pliances, basement, garage. Available
 now at \$400 firm. 647-0761

BLOOMFIELD HILLS - Mulberry
 Square 2 bedroom, 2 bath 2nd-floor
 condominium. Kitchen appliances, car-
 peting, drapes, carpet. Adults, no pets.
 Available now at \$550.

BIRMINGHAM - 3 bedroom brick
 ranch, screened & glassed porch, 2 car
 garage, kitchen appliances, carpeting
 drapes. Available now at \$575.

STEELE HTS. - 4 bedroom, 2 1/2 bath
 colonial. Family room with fireplace,
 carpeting, drapes, all appliances, at-
 tached garage. Available now at \$609.

BIRMINGHAM - in town, rent, 3
 bedrooms, short term, long term avail-
 able, immediate occupancy 646-2826

BIRMINGHAM & OAK PARK AREAS
 Beautiful 2 and 3 bedroom homes. Car-
 peting & appliances. Near expressways,
 2 1/2 car garage with openers. Available
 April 1 at \$650.

BIRMINGHAM 1327 Cole, 2 1/2 bed-
 rooms, 1 story, basement, appliances,
 carpeted, fenced yard, \$425 per Mo
 288-5220 or 646-8330

BIRMINGHAM 1999 Haynes
 Clean 2 bedroom ranch, carpeting, ap-
 pliances, fenced yard, gas heat, near
 commuter \$375 plus security \$45 1232

BIRMINGHAM 2 bedroom, appliances,
 washer, dryer, carpeting, air condition-
 er, basement, garage, fenced, clean.
 \$400 month Security Evgs 641-7472

BIRMINGHAM 2 bedroom, all appli-
 cations, 1 1/2 car garage, newly decorated,
 near V. \$375 per month plus security
 \$395 per month. 681-0816

404 Houses For Rent
 BIRMINGHAM - 3 bedroom brick
 ranch, fireplace, carpeting, kitchen ap-
 pliances, basement, garage. Available
 now at \$400 firm. 647-0761

BLOOMFIELD HILLS - Mulberry
 Square 2 bedroom, 2 bath 2nd-floor
 condominium. Kitchen appliances, car-
 peting, drapes, carpet. Adults, no pets.
 Available now at \$550.

BIRMINGHAM - 3 bedroom brick
 ranch, screened & glassed porch, 2 car
 garage, kitchen appliances, carpeting
 drapes. Available now at \$575.

STEELE HTS. - 4 bedroom, 2 1/2 bath
 colonial. Family room with fireplace,
 carpeting, drapes, all appliances, at-
 tached garage. Available now at \$609.

BIRMINGHAM - in town, rent, 3
 bedrooms, short term, long term avail-
 able, immediate occupancy 646-2826

BIRMINGHAM & OAK PARK AREAS
 Beautiful 2 and 3 bedroom homes. Car-
 peting & appliances. Near expressways,
 2 1/2 car garage with openers. Available
 April 1 at \$650.

BIRMINGHAM 1327 Cole, 2 1/2 bed-
 rooms, 1 story, basement, appliances,
 carpeted, fenced yard, \$425 per Mo
 288-5220 or 646-8330

BIRMINGHAM 1999 Haynes
 Clean 2 bedroom ranch, carpeting, ap-
 pliances, fenced yard, gas heat, near
 commuter \$375 plus security \$45 1232

BIRMINGHAM 2 bedroom, appliances,
 washer, dryer, carpeting, air condition-
 er, basement, garage, fenced, clean.
 \$400 month Security Evgs 641-7472

BIRMINGHAM 2 bedroom, all appli-
 cations, 1 1/2 car garage, newly decorated,
 near V. \$375 per month plus security
 \$395 per month. 681-0816

404 Houses For Rent
 CLARKSTON - all sports Walters Lake
 Frontage 3 bedroom, 2 bath, on park
 like setting, well insulated, low heat
 bills. No pets. Immediate occupancy. 1
 year lease. \$500 plus security deposit.
 references required. Eve 682-6290

CLARKSTON - 2,100 sq ft on 1/4 acre
 3 bedrooms, 2 1/2 baths, fireplace, hot
 water heat, central vac, intercom, wa-
 ter softener, etc. Tastefully decorated.
 Close to I-75, Clarkston Schools. Refer-
 ences & deposit required. For more de-
 tails call evening 313-623-3914

CANTON 4 bedroom, 2 bath, family
 room, living room, 1 car garage War-
 ren - Lilley area \$550 per month
 Available April 1. Days 323-0611. Evgs
 453-7309

CANTON - 3 bedroom brick ranch, full
 basement. Plymouth Schools. Stove &
 refrigerator 1 year lease. \$450 mo plus
 utilities. 459-0853 1-519-948-2137

CANTON-3 bedroom, family room,
 stove & refrigerator, great area \$420
 month plus deposit. 721-8869

CANTON 3 bedroom brick ranch, with
 aluminum siding, 2 car attached gar-
 age, central air, 1 1/2 baths. fireplace,
 \$495 month plus utilities. 592-1956

CASS LAKE small 2 bedroom furnished
 house, \$280 month, utilities included
 \$300 security deposit. Lake access.
 729-5845

CLARKSTON - 4 bedroom, 1 1/2 bath Co-
 lonial. Family air patio \$550 mo plus
 1st mo rent. \$825 Security Call after
 6PM 623-1276 or 623-6391

COLONIAL - TROY 4 bedrooms, 2 1/2
 baths, family room fireplace, base-
 ment, large garage, 2 years old. 642-2414

COMMERCIAL New 2 bedroom, lake
 privileges, short term possible. \$350
 plus utilities and security. 851-9056

400 Apartments For Rent

2 Bedroom Townhouse

HUNTINGTON GARDEN TOWNHOUSES

A most practical ad- from Highly rated OAK PARK schools. Private front
 dress. Access from Rakkham Golf Course. \$315 & rear doors & private
 Close to Southfield. full basement. Beauti-
 Birmingham, Troy, fully landscaped,
 etc., Freeways, quiet & suburban.
 Shopping, every- (Sorry, NO pets)
 thing. Open Dai- Michigan's Biggest
 ly. "Apt" Value!

GOODE 647-1898
 REAL ESTATE
 1411 N. Woodward, Birmingham

10711 W. TEN MILE/OAK PARK/564-6073

GRAND OPENING

You can
 get into Muirwood
 for \$350 a month.
 But only
 through the 24-hour,
 manned gatehouse.

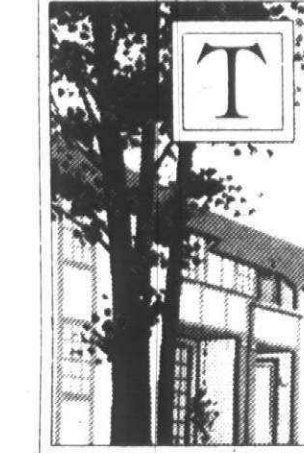

he peace and security of a
 round-the-clock manned gatehouse
 and electronic door entries are
 unheard of in apartments priced this
 reasonably.
 But then, Muirwood has so many
 creature comforts you just won't find
 anywhere else for the money.
 So much light, so many windows,
 so much room. Covered attached
 parking. Windows in most kitchens.
 (Eating space, too!) Lots of storage,
 huge closets. Incredible pool and
 clubhouse. A balcony or patio in each residence.
 Great architecture, great setting: ponds, rolling
 hills, even a private 12-acre nature trail.
 Starting at \$350 a month for a one-bedroom.
 And - amazingly - just \$390 a month for our
 two-bedroom apartments.

MUIRWOOD
 Grand River and Drake, Farmington Hills
 Models open everyday, 11-6.
 Phone: 478-5533

WELLESLEY
 our townhouses are homes

TOWNHOUSE COOPERATIVE
 IMMEDIATE OCCUPANCY
 ON 1 & 2 BEDROOMS

FROM \$197

ON
 SUBSCRIPTION TV
ONE FULL YEAR FREE
 UPON APPROVAL FOR RESIDENCY

- NO INSTALLATION CHARGE
- NO CHARGE FOR DECODER BOX
- NO MONTHLY CHARGE
- OFFER EXPIRES MAY 1, 1981

*Pending ON-TV Credit Approval

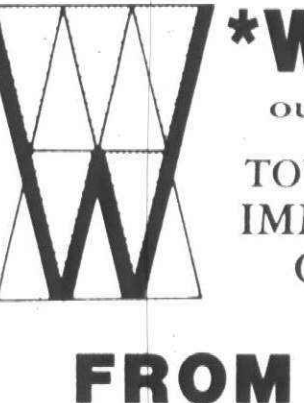

1, 2 & 3 BEDROOMS
 TAX ADVANTAGES OF HOME OWNERSHIP
 NO MAINTENANCE HEADACHES
 FULL BASEMENT
 COLOR COORDINATED APPLIANCES
 WALK TO SHOPPING
 SENIOR CITIZENS ACTIVITIES
 SENIOR CITIZENS GIVEN
 SPECIAL CONSIDERATION
 NEAR I-94 AND I-275

OPEN
 MON.-FRI. 1-5
 SAT. & SUN. 12-5
 equal opportunity housing
729-3328

PROFESSIONALLY MANAGED BY P.M. ONE

STONEYBROOKE APARTMENTS
 Joy Road at I-275, 30 minutes to Downtown Detroit
 • Spacious 1 & 2 Bedroom Apartments
 • Pool-Tennis-Clubhouse
 • 1 1/2 Baths • Plymouth Schools
 Senior Citizens Discounts

From **\$260**
 • HEAT INCLUDED •
 Cooking gas included Immediate Occupancy
 MODEL OPEN 9-5 DAILY, 12-5 WEEKENDS

Equal Opportunity Housing
455-7200

FAIRMONT PARK

because I
 love the look on
 my friends' faces
 when they see
 how much
 apartment I got
 for so little."



9 Mile & Drake Roads,
 FARMINGTON HILLS
 474-2510

VILLAGE OAKS
 Apartments
 Spacious 1 & 2 Bedroom
 Apartments in Farmington Hills

Includes: carpeting, drapes,
 appliances and heat.
 Adults only, no pets.
 From \$300.

474-1305

Beautiful 1 & 2 Bedroom
 Apartments from \$225

- Shag Carpeting
- Pool
- Modern Kitchens
- Clubhouse
- Air Conditioning
- Convenient to 12 Oaks Mall
- Balconies

Heat Included • 6 Month Leases Available

The Village

IN WIXOM

At Pontiac Trail & Beck Rds. (Take Beck Rd. Exit
 north 1 1/2 miles from I-96) Open daily & weekends,
 11am-7pm. Sorry no pets. Phone: 624-6464

FAIRMONT PARK

... because even
 if you've got a
 roommate, the
 design of the
 apartment makes
 you feel like
 you don't."



9 Mile & Drake Roads,
 FARMINGTON HILLS
 474-2510

Scottdale
 Apartments

Newburgh Road between Joy & Warren 1 Mile to
 I-275 or I-96, 30 minutes to Downtown Detroit

- Large 1 & 2 Bedrooms
- Covered Parking
- Pool-Tennis-Clubhouse
- 1 1/2 Baths
- Park Areas
- Livonia Schools

Senior Citizens Discounts

FROM **\$280**
 • HEAT INCLUDED •
 Cooking gas included, Immediate Occupancy
 Model Open 9-5 Daily, 12-5 Weekends

Equal Opportunity Housing
455-4300

POSH!

The Summit. Award-winning landscaping.
 • Superb interior appointments. • Private and
 prestigious address. • Individual heating and
 cooling controls. • Uncompromising standards
 throughout. • Pool, Spa, Tennis Clubhouse.

The Summit, 1,800 Sq. feet, 2 bedroom,
 2 bath apartments with all appliances and full
 carpeting... from \$575.00.

Rental Office
 SUMMIT NORTHWESTERN 851-1055
 AT MIDDLEBELT 557-9620

Managed by
 Kaftan

Don't sign that lease!
 unless you have
\$285.00
 PER MONTH RENT
 PLUS: YOU GET ALL THE ITEMS BELOW AT
 NO CHARGE!!!!

- YES NO
- heat and hot water
- indoor swimming pool (swim while it snows)
- outdoor pool - huge sun deck
- 18-hole golf course (no charge)
- bi-in vacuum and all attachments
- clubhouse and ballroom
- tennis courts
- washer and dryer (in each apt. free)
- fully carpeted - carpeted halls
- air conditioning
- range, refrigerator, disposal
- large walk-in closets
- beautiful view
- spacious parking areas
- well lit area
- fountain and putting green
- lift of living
- hair salon (permission only)
- close access to x-way.
- Santa buses to property

1 and 2 bedroom apts. and 3 bedroom Townhouses, 2,400 sq. ft.
 (We also have a few units at \$270)
 Furnished Apartments Available
 Located at Corner of 4 Roadside
 U.S. 275 - 10 Mile - Halstead
 and Grand River
 FARMINGTON HILLS

Independence Green
474-7284 APARTMENTS 477-0133

LAUREL WOODS
 Apartments

Luxurious adult

404 Houses For Rent

DEARBORN HILLS, Brick Bungalow, 2 bedrooms, 2 baths, fireplace in large living room, dining room, kitchen with eating space, 2 1/2 car garage, basement, refrigerator-stove, dryer, carpeted, fresh paint, \$500 per month, no pets, security deposit, a reference is required. 587-8682 946-7788

404 Houses For Rent

NEAR Metro Airport. Small 2 bed room. Large lot. \$280 per month. Call O.K. Call Sunday. 721-6377

404 Houses For Rent

TROY, Crooks & Square Lake Rds., 3 bedrooms, 2 1/2 baths, newly decorated, heat, \$450. Days 355-4545 851-6450

412 Townhouses-Condos For Rent

BIRMINGHAM - 3 bedrooms, newly re-modeled. New appliances, dishwasher, basement. Excellent area. \$500 month plus deposit. Between 4-5 385-1350

414 Florida Rentals

ABANDON YOUR HUNT Florida Rentals Tenants & Landlords Share Listings 642-1620

416 Vacation Rentals

GRAND TRAVELER BAY, 5 bedroom executive home, 85 ft. from water, sandy beach, patio, sun deck, completely furnished, privacy, \$unk. Available by week of month through Sept. 15. 851-8013

422 Commercial & Industrial For Rent

BRIGHTON - for lease 6000 sq. ft. building, has showroom with office above, two 14' loading doors, 10,000 sq. ft. paved parking, 4986 Old U.S. 23 near Grand River. 227-4484

424 Office & Business Space

FARMINGTON, 12 MILE RD with new, fully furnished room for rent with answering service. Secretarial services also available. 583-0900

424 Office & Business Space

3 offices & large reception area. Cool Jig & Big Beaver. \$616 per month. 852-8200

FARMINGTON HILLS Orchard Lake Rd., 1 Blk. S. of 14 LUXURIOUS CONDOMINIUMS FOR RENT 2 bedrooms, 2 1/2 baths, laundry room, 2 car attached garage, full basement, fireplace, full patio, central air, dishwasher, and many other features. \$890.00/month LIMITED UNITS AVAILABLE Hours: 1:00 to 8:00 except Thurs Phone: 851-9557

PROFESSIONAL OFFICE BUILDING AVAILABLE 3,000 SQ. FT. Will Divide Close proximity to 4 Communities Parking Suburban Gallery of Homes 277-2700 274-6794

Century 21 VINCENT N. LEE, EXECUTIVE TRANSFER SALES 851-4100

Century 21 PIETY HILL, INC. 642-8100

RED WING TICKET WINNER Kent Darzi 5738 Pembshire Birmingham Please call the promotion department of the Observer & Eccentric by 5 p.m. Friday, March 13, 1981 to claim your 2 free RED WING TICKETS 591-2300 ext 244

Century 21 CONGRATULATIONS! FARMINGTON HILLS - prime Echo Valley, beautifully decorated, 2 bedrooms, 2 full baths, dining room, large kitchen, pool, clubhouse & pool. \$475.00. Heat included. 559-8242. 642-3023

FREE FIRST MONTH FOR IMMEDIATE OCCUPANCY Large beautiful 2 bedroom 1 1/2 bath in suburban in deluxe area. Recently built, air conditioning, in-unit laundry, appliances, dishwasher, central air, full kitchen, carpeting, drapes, central heat & air conditioning. Call for details. 446-0524

RESIDENT MGR. 355-3253 LOVE CHILDREN AND PETS 2038 STARR-ROYAL OAK LUXURY TOWNHOUSE 2 KING SIZE BEDROOMS, spacious living room, wood burning fireplace, formal dining room, kitchen snack bar, full bathroom, tile vestibule, basement, patio, central air, dishwasher, self clean oven, refrigerator, \$435. 544-3200

418 Mobile Homes For Rent MODERN ONE BEDROOM furnished mobile home. Farmington location. References and security required. 478-0973 478-2999

415 Halls For Rent FARMINGTON K of C HALL 21900 Middlebelt Air Conditioned, Paved Parking WEDDINGS-BANQUETS SHOWERS-PARTIES Package Deal Our Specialty Mon-Fri 10-3, Mon Even 6-8 300 Call 476-1100

Chamberlain 6 47-5100 BUILDING FOR RENT in Westland with air conditioning, heat and parking lot. Ideal for insurance, real estate, etc. 425-4635

DOCTOR Lease a medical suite in Farmington Hills. Modern building with elevator, doctors lounge with sauna, exercise room, and shower. convenient to Northwest area hospitals and express ways. Inspect the facility at your convenience. Ask for Mary Bush. Call 353-7700. Thompson-Brown

Commercial Space Available in High Rise Bldg. Located in Southfield. Ideal for Doctor. Area consists of reception room, waiting room, lab room, doctor's office and 2 restrooms. 557-6116

DOCTOR Lease a medical suite in Farmington Hills. Modern building with elevator, doctors lounge with sauna, exercise room, and shower. convenient to Northwest area hospitals and express ways. Inspect the facility at your convenience. Ask for Mary Bush. Call 353-7700. Thompson-Brown

DOCTOR Lease a medical suite in Farmington Hills. Modern building with elevator, doctors lounge with sauna, exercise room, and shower. convenient to Northwest area hospitals and express ways. Inspect the facility at your convenience. Ask for Mary Bush. Call 353-7700. Thompson-Brown

DOCTOR Lease a medical suite in Farmington Hills. Modern building with elevator, doctors lounge with sauna, exercise room, and shower. convenient to Northwest area hospitals and express ways. Inspect the facility at your convenience. Ask for Mary Bush. Call 353-7700. Thompson-Brown